

**INTERNATIONAL SCIENTIFIC  
ONLINE CONFERENCE**



Global Conference Hub

# **INTERNATIONAL MULTIDISCIPLINARY SCIENCE CONFERENCE**

**ITALY**

<http://globalconferencehub.org>



**INTERNATIONAL MULTIDISCIPLINARY  
SCIENCE CONFERENCE**  
VOLUME-1, ISSUE-2, 2026

**INTERNATIONAL MULTIDISCIPLINARY SCIENCE  
CONFERENCE:** a collection scientific works of the International scientific  
conference (February, 2026) – Italy: 2026. Volume-01, Issue 02, 2026

**Languages of publication:** English, Russian, and Uzbek

This collection includes research papers presented by scientists, graduate students, and students at the International Scientific Online Conference “**INTERNATIONAL MULTIDISCIPLINARY SCIENCE CONFERENCE**” held in Italy on February, 2026.

The conference proceedings are intended for researchers and academic staff of higher education institutions. They may be used for teaching and research purposes, including postgraduate education and preparation for bachelor’s and master’s degree programs.

All submitted articles underwent peer review by qualified experts. The materials are published in accordance with copyright regulations. The authors are fully responsible for the accuracy of the content, research findings, and any errors.

**Quantumqill Research Press PVT LTD, 2026**

## **ANALYSIS OF FACTORS INFLUENCED IN THE DEVELOPMENT OF THE POULTRY INDUSTRY**

Independent researcher at Termez State University  
Hayitnazarova Holida Bekmurzayevna  
E-mail: hayitnazarovaholida@gmail.com

**Abstract.** This thesis examines the theoretical and methodological foundations of strategic development of the poultry industry. The development strategy of the poultry sector is interpreted as a process of rational resource allocation, implementation of a set of measures, and ensuring sustainable development of poultry farms in the long term. The social, economic, organizational, and technical characteristics of the poultry industry and its role within the agro-industrial complex are analyzed. Particular attention is paid to the high productivity of poultry farming, feed conversion efficiency, and the importance of egg and meat production in ensuring food security. The current state and structural composition of the poultry industry in Uzbekistan are reviewed based on statistical data. The research findings provide a methodological basis for developing effective strategies for the sustainable development of the poultry sector.

**Keywords:** poultry industry, strategic development, agricultural sector, food security, egg production, meat production, production efficiency

**Аннотация:** В данном тезисе рассмотрены теоретико-методологические основы стратегического развития отрасли птицеводства. Стратегия развития птицеводства интерпретируется как процесс рационального распределения ресурсов, формирования комплекса мероприятий и обеспечения устойчивого развития птицеводческих хозяйств в долгосрочной перспективе. Проанализированы социально-экономические и организационно-технические особенности птицеводческой отрасли, а также её роль в агропромышленном

комплексе. Особое внимание уделено высокой продуктивности отрасли, эффективности конверсии кормов и значению производства яиц и мяса для обеспечения продовольственной безопасности. На основе статистических данных рассмотрено современное состояние и структура птицеводства в Республике Узбекистан. Результаты исследования могут быть использованы при разработке стратегий развития птицеводческой отрасли.

**Ключевые слова:** птицеводство, стратегия развития, аграрный сектор, продовольственная безопасность, яичное производство, мясное направление, эффективность производства

We have defined the strategic development of the poultry industry as follows: this is a rational allocation of resources and a set of measures in the industry, in the process of which a sustainable development strategy for poultry farms is developed and implemented, as well as the process of creating and implementing goals, objectives and recommendations that are reflected in a long-term strategy, a program document. As a result of the implementation of the economic development strategy, such dynamics are created in the industry that ensure the achievement of the main goal, which determines the factors of development of the poultry industry.

When developing industry development strategies, it is important to consider that strategic plans should reflect the nature and consequences of factors with short, medium, long and permanent effects, which can lead to a potential decrease in the efficiency of production and sales of products. In addition, when developing a strategy for the development of poultry industries, it should be taken into account that factors can be controllable, partially controllable and uncontrollable [6, page 184].

Developing a development strategy for the poultry industry is a rather laborious process, since agriculture itself has a number of characteristics, and the poultry industry

is very specific to the agricultural sector. It is these characteristics and the laws of the development of the industry that should be taken into account when developing a development strategy for the poultry industry in the future.

Summarizing the specialized literature, the following main features of agricultural production can be distinguished:

- socio --economic characteristics (various forms of ownership - federal, municipal, private, etc.; variety of organizational and legal forms of economic management -- producer agricultural cooperatives, societies, peasant (farmer) farms; personal subsidiary farms of the population);
- organizational -and technical characteristics (the development of agriculture is based on the use of bioclimatic potential; land and water are the main and irreplaceable means of production; the dependence of production on natural climatic conditions; spatial distribution of production; seasonality of production; specialization and concentration).

The poultry industry also has its own socio-economic and organizational --technical characteristics, which are determined by the specificity of the industry and the level of development. Poultry farming is the most dynamic and science-based sector of the agro-industrial complex, characterized by: rapid increase in the number of livestock, intensive growth, high productivity and sustainability, minimal consumption of living labor and material resources per unit of output.

Poultry has the highest efficiency: in terms of converting plant protein into animal protein, it has a significant advantage compared to other types of livestock (cattle, sheep). Self- paying features there is was network to be , its intensity indicators high to be with For example , a kilogram egg mass or broiler meat 1.8-2 kg of feed during cultivation conversion need will be ;

- horse for one kilogram meat working 6-8 kg of feed per day demand will be done ;

- cow meat for and 7 -10 kg of feed demand will be done .

Alive mass according to food- protein working release indicators , example for , egg-maker in chickens , 8000 liters per year milk giving to the cow relevant from the indicator 8 -10 times high will be . Poultry fast short within the period egg and meat products less cholesterol , dietary product as delivery give to take to the ability These products have was demand poultry farming industry our both at home and abroad faster than anywhere else to develop contribution Addictive .

Poultry farming main directions – egg production and butcher ; assistant products – feather , down, organic fertilizer ( poultry) garbage ). Village farm birds inside wide widespread type – chickens , turkeys , geese , ducks , guinea fowl chickens , quails , even ostriches cultivation is also increasing expanding is going on . In Uzbekistan poultry farming of the association to the information according to , in the country village farm enterprises enlarged poultry according to total adults of birds in the composition chickens 95-98%, ducks 1%, geese 0.5%, turkeys ( indeicas ) 0.4%, quails 0.1 % organization does .

Poultry farming field productivity according to egg and meat working issuer farms combines : large industry poultry farming complexes or integrated poultry farming forms , specialized poultry farming farms ( poultry farming) factories ) and personal assistant farms . Bird cultivation and poultry farming in factories chickens , geese , ducks , turkeys , quails is cultivated . Every one bird type two main to the group divided into : age poultry and big birds . Young poultry and productive to the goal according to : generation ( re) work ) and meat in the direction of is separated . Again in recovery young poultry and own in turn generation seeded of the group instead pressing for cultivated young poultry and industry seeded of the group instead pressing for

cultivated young poultry will be . Big the birds also have them working release to the purpose looking at classified : genus grouping poultry ( main rows ) , parent- grouping poultry and breeding grouping poultry ( chickens , ducks , turkeys , geese , quail , guinea fowl) chickens ) and industry grouping poultry ( chickens , guinea fowl) chickens , quails ).

Poultry farming networks types according to separates :

1. Product – eggs and meat in the direction of networks , they directly poultry meat and egg working releases ;
2. Specialized networks – farmer farms ( paternity) without foundation ) and poultry farming farms , associations within technological cooperation based on activity runs and closed working release per cycle has will be ;
3. Trade farms for , hybrid chicken – chicks cultivation with is engaged in ;
4. Breeding enterprises , they there is breeds improvement and special bird breeds and hybrid lines create , rooster-chicken and hybrid forms working release , hybrids cultivation with engages in them commerce enterprises and incubation -poultry farming to the stations delivery gives ;
5. Incubation -poultry farming stations [3, page 113].

Current at the time In Uzbekistan , according to ( UzStat ) according to , 2024 at the end poultry farming from 230 in the field more than large and middle enterprises activity 60% of which are eggs in the direction of ( this including generation egg in the direction of ) , 35% broiler In the direction of , 1% duck farming , 0.5% goose farming , 3% turkey farming ( indeikas ) , and 0.1% quail farming are farms .

So poultry farming network develop factors formation for methodical approaches necessary , they In Uzbekistan and in general region under the circumstances specialized poultry farming farms development dynamics , itself originality and development features in consideration able to methodological approaches necessary .

### LIST OF REFERENCES USED

1. O‘zbekiston Respublikasi Davlat statistika qo‘mitasi. *Qishloq xo‘jaligi va parrandachilik statistik ko‘rsatkichlari*. — Toshkent, 2020–2024 yillar.
2. Mirzayev B. Qishloq xo‘jaligi tarmoqlarini rivojlantirish strategiyasini ishlab chiqish masalalari // *Agroiqtisodiyot*. — 2021. — №2. — B. 112–120..
3. Porter M. E. *Competitive Strategy: Techniques for Analyzing Industries and Competitors*. — New York: Free Press, 2008.
4. Ansoff I. *Strategic Management*. — London: Palgrave Macmillan, 2007.
5. Semyonov V. A., Ivanov A. P. *Птицеводство: экономика и организация производства*. — Москва: Колос, 2016.
6. Kuznetsov V. V. Стратегия развития агропромышленного комплекса // *Экономика сельского хозяйства России*. — 2019. — №5. — С. 110–118.
7. FAO. *Poultry Development Review*. — Rome: Food and Agriculture Organization of the United Nations, 2013.

## **ANALYSIS OF THE USE OF THE ARIMA MODEL IN FORECASTING ECONOMIC INDICATORS**

**Independent student of Termez State University,  
Turopova Sohiba Djumanazarovna  
Email: turopovasohiba@tersu.uz**

**Abstract:** This article examines the analysis and forecasting of wholesale trade volume in the Surkhandarya region using time series methods the ARIMA model was applied to predict future values of the wholesale trade indicator. The stationarity of the time series was tested using the Augmented Dickey–Fuller test The findings of the study can be effectively used in regional economic planning and trade development strategies

**Keywords:** wholesale trade, time series analysis, ARIMA model, forecasting, stationarity, Augmented Dickey–Fuller test, economic analysis.

**Аннотация.** В исследовании использованы статистические данные и применена модель ARIMA для прогнозирования будущих значений экономического показателя. Стационарность временного ряда была проверена с помощью расширенного теста Дики–Фуллера. Результаты исследования могут быть использованы при разработке региональных программ социально-экономического развития.

**Ключевые слова:** временные ряды, модель ARIMA, прогнозирование, стационарность, тест Дики–Фуллера, экономический анализ.

Autoregressive modeling (Autoregressive, AR) and moving average Modeling (Moving Average, MA) time rows forecast to do two kind ARIMA model exactly this two approach unites , therefore for him too name so Forecasting is mechanical of learning one direction It is time. of the row past to their behavior based on the future one

or one how many values prophecy to do goal does . Imagination do it , you small the store filling for ice cream buy If the weather is warming with ice cream trade regular accordingly exceed going if you know , next per week order size this from the week a little more to be guess you do logically right will be . The order how much more to be and this of the week trade size past from the week how much difference to what he did related We will see the future . past with without comparison standing prophecy can We can't . This because of , in the past timely row data ARIMA model for , in general all forecast and timely rows analysis methods very much for important is considered .

"Autoregressive Integrated Moving Average" , used in the forecasting process is one of the widely used statistical methods for analyzing time series. Typically, this model consists of three main parameters, which are specified in the order  $(p, d, q)$ . Here:  $p$  is the level of the autoregressive component,  $d$  is the level of integration or differentiation, and  $q$  is the level of the moving average component.

The ARIMA model is essentially an ARMA (Autoregressive Moving Average) model adapted to non-stationary time series. If the time series is not initially stationary, it can be made stationary by differentiating it to a certain order. The series obtained after this process are called differentiated or integrated stationary series. Thus, after the  $d$ -order differentiation is performed in the ARIMA( $p,d,q$ ) model, the remaining parts are adapted to the ARMA( $p,q$ ) model.

Various statistical tests are used to determine the stationarity of a time series. These tests determine the presence of unit roots and the degree of integration of the time series (usually 1st or 2nd degree). If the series has a unit root and its degree of integration is greater than zero, then the series can be made stationary by differentiating it. After that, an ARMA model can be built for the new series, since it now has a stationary property, which makes it possible to perform analysis and forecasting reliably.

non-stationary  $Y_t$  time series, the ARIMA(p, d, q) model has the following general form:

$$\Delta^d Y_t = c + \sum_{i=1}^p \varphi_i \Delta^d y_{t-i} + \sum_{j=1}^q \theta_j \Delta \varepsilon_{t-j} + \varepsilon(t) \quad (1)$$

$\Delta$  order differences in sequence : first the original time series is differentiated, then the resulting first- order difference row , then second in order differences and etc. This in a way , time row stationary to the situation will be brought and analysis for adapts .

Determining the stationarity of a time series is very important for subsequent analysis processes. A stationary process is a stochastic process whose probability distribution remains unchanged over time and whose mean and variance are constant. Since many methods in time series analysis are based on stationary processes, non-stationary data are often brought to a stationary form using appropriate transformations. Stationarity violations are often caused by changes in the mean value over time, which can be associated with the presence of a trend or a unit root. It can also be seen from dynamic graphs that if a time series does not oscillate around a certain constant value, this indicates that it is non-stationary. The augmented Dickey-Fuller (ADF) test is widely used to determine whether a given time series is stationary or non-stationary. This test is one of the most effective and popular methods in statistics and serves to assess the stationarity of a time series.

The first step in constructing an ARIMA model is to determine the order of differentiation necessary to make the time series stationary. The ADF test is mainly designed to check statistical significance, and it calculates the test statistic and p-value by comparing the null and alternative hypotheses. Based on the test results, it is possible to conclude whether the series is stationary or not. In the next step, it is important to determine the autoregressive (p) and moving average (q) parameters. To do this, the

||

correlogram of the time series (i.e., the ACF and PACF graphs) is analyzed. The autocorrelation (ACF) and partial autocorrelation (PACF) functions of the time series have a specific form for different ARIMA models. However, it is not always easy to accurately determine the parameters  $p$  and  $q$  based on the ACF alone, especially when  $q=0$ . To solve this problem, the PACF analysis of  $Y_t$  as a stationary process is very useful. The ACF function approaching zero after lag  $q$  indicates that the model is  $MA(q)$ , while the PACF function approaching zero after lag  $p$  indicates that the model is  $AR(p)$ . Therefore, ACF and PACF analyses help to more accurately identify ARIMA ( $p, d, q$ ) models, especially when both  $p$  and  $q$  are non-zero.

The table below summarizes the ACF and PACF properties of popular ARIMA models for stationary time series.

**Table 1.**

**Generalized properties of ACF and PACF functions for time series models<sup>1</sup>**

Model	ASF	PSF
<i>White Noise, MA(0)</i>	When $k \neq 0, \rho(k) = 0$	When $k \neq 0, \rho_{part}(k) = 0$
<i>AR(1), <math>a_1 &gt; 0</math></i>	Exponential Decay: $\rho(k) = a_1^k$	$\rho_{part}(1) = a_1,$ $\rho_{part}(k) = 0, k \geq 2$
<i>AR(1), <math>a_1 &lt; 0</math></i>	Vibration reduction: $\rho(k) = a_1^k$	$\rho_{part}(1) = a_1,$ $\rho_{part}(k) = 0, k \geq 2$
<i>AR(p)</i>	Zeroing in with probable fluctuations	$k \geq p$ to zero in
<i>MA(1), <math>b_1 &gt; 0</math></i>	positive peak at $k=1,$ $k > 1$ to zero in	Vibration reduction: $\rho_{part}(1) > 0$

<sup>1</sup> V.P. Nosko . Econometrics. Introduction to regression analysis of time series. Moscow 2002.40-41 ctr .

$MA(1), b_1 < 0$	negative peak at $k=1$ , $k > 1$ to zero in	Decrease in absolute value: $\rho_{part}(k) < 0, k \geq 1$ at
$MA(q)$	$k \geq p$ to zero in	

$k$  is defined as the correlation coefficient between  $\rho_{part}(k)$  the value of the lag  $Y_t$  and  $Y_{t+k}$  the random variables, where the effect of the random variables  $Y_{t+1}, \dots, Y_{t+k-1}$  is eliminated. This is  $\rho_{part}(k) Y_{t-1}, \dots$ , is the coefficient in the linear combination  $Y_{t-k}$  of random variables  $Y_t$  that best approximates the random variable  $Y_{t-k}$ . Here,  $\rho_{part}(k)$  the first  $k$  are defined as the solution of the system of Yule-Walker equations  $a_k$  with respect to .

$$r(s) = a_1 r(s-1) + a_2 r(s-2) + \dots + a_k r(sk), s = 1, 2, \dots, k,$$

In order to forecast the volume of wholesale trade in the region, available statistical data was analyzed and based on them, an "ARIMA" model was developed.

### LIST OF USED LITERATURE

1. Box G. E. P., Jenkins G. M., Reinsel G. C., Ljung G. M. *Time Series Analysis: Forecasting and Control*. — 5th ed. — Hoboken: John Wiley & Sons, 2015.
2. Gujarati D. N., Porter D. C. *Basic Econometrics*. — 5th ed. — New York: McGraw-Hill, 2009.
3. Enders W. *Applied Econometric Time Series*. — 4th ed. — New York: Wiley, 2014.
4. Hamilton J. D. *Time Series Analysis*. — Princeton: Princeton University Press, 1994.

5. Dickey D. A., Fuller W. A. Distribution of the estimators for autoregressive time series with a unit root // *Journal of the American Statistical Association*. — 1979. — Vol. 74(366). — P. 427–431.
6. Hyndman R. J., Athanasopoulos G. *Forecasting: Principles and Practice*. — Melbourne: OTexts, 2018.
7. Brockwell P. J., Davis R. A. *Introduction to Time Series and Forecasting*. — 3rd ed. — New York: Springer, 2016.
8. Wooldridge J. M. *Introductory Econometrics: A Modern Approach*. — 6th ed. — Boston: Cengage Learning, 2016.
9. O‘zbekiston Respublikasi Davlat statistika qo‘mitasi. *Hududlar kesimida savdo statistikasi*. — Toshkent, 2010–2024 yillar.

## **INFORMATION TECHNOLOGIES OF TEACHING IN LINGUISTICS**

**Abdurakhmanova Rano Abdubakiyevna**  
**Professional College of Syrdarya Region,**  
**Akaltin District**

***Abstract:** This article describes information technology in linguistic research. It also explores the scientific methodology of this technology in various fields of linguistics, including structural linguistics, sociolinguistics, psycholinguistics, and computational linguistics.*

***Key words:** technology, linguistics, computer science, language, computer, skills, formation.*

## **ИНФОРМАЦИОННЫЕ ТЕХНОЛОГИИ ОБУЧЕНИЯ В ЛИНГВИСТИКЕ.**

**Абдурахманова Рано Абдубакиевна**  
**Профессиональный колледж Сырдарьинской области**  
**Акалтынского района**

***Аннотация:** В статье дано описание информационной технологии в лингвистических исследованиях. Характеризуется изучение научной методологии данной технологии в разделах лингвистики, в частности, структурной лингвистики, социолингвистики, психолингвистики, компьютерной лингвистики.*

***Ключевые слова:** технология, лингвистика, информатика, язык, компьютерный, навыки, формирование.*

В наши дни информационные технологии стали неотъемлемой частью обучения языку, независимо от сферы деятельности, лингвистики. Современному лингвисту в плане компетенции, с использованием информационной технологии, хотя уже достаточно долго сформировывались навыки компьютерных знаний. Для становления специальности русского языка существуют определённые программы в лингвистических исследованиях, переводе и в обучении языку.

В сфере лингвистической деятельности существует понятие «Информационные технологии в лингвистике», что непосредственно усовершенствует языковые знания и навыки в сфере лингвистики. Данная технология даёт возможность изучения компьютерной лингвистики, применение знание информатики в своих исследованиях специалистами-лингвистами. Вопросы порождения языка также даёт социализацию и варьирования, изучает языковой уровень в тексте с точки зрения разделов лингвистики. Изучаемый языковой уровень, а также, научная методология выделяет различные разделы лингвистики, например структурная лингвистика, социолингвистика, психолингвистика и т.п. При использовании информационной технологии в лингвистических исследованиях целесообразно изучить теоретическую и прикладную лингвистику.

Теоретическая лингвистика — это раздел языкознания, изучающий объективный строй отдельного языка, его истории и закономерностей. Создавая модель объекта одного языка, теоретическая лингвистика создаёт базу для практического применения в коммуникации, а применение информационных технологии в данном процессе, придаёт более масштабный характер.

Прикладная лингвистика изучает использование знаний языка на практике. С применением информационной технологии создаются автоматические системы обработки информации. Современная прикладная

лингвистика оптимизирует использование языка и выделяет следующие группы: традиционные и новые. В рамках традиционного направления языковое строение рассматриваются со стороны совершенствования: письменности, транскрипции устной речи, транслитерации иностранных слов, стенографии, систем для незрячих людей.

Прикладная лингвистика разрабатывает механизм перевода, автоматизирует анализ и синтез текста. Образуется особая лингвистика в мире информационного потока слов, языковых конструкции и выражении, что постепенно превращается в предмет изучения компьютерной лингвистики. Инструментами компьютерной лингвистики являются определённые программы, технологии по обработке данных с целью моделирования языка в зависимости от окружающего мира коммуникации. В компьютерной лингвистике существуют ряд направлений, анализирующие и синтезирующие текст, создают информационно-поисковые системы, в частности, машинный перевод. [1,36]. Информационные технологии на основе компьютерной лингвистики создают обучения языка, лингвистическую базу данных программных инструментов в рамках лингвистики в целом. Язык представляет общение в социуме, имеющее представление в знаках, то есть, сфера общения по определённым понятиям.

В истории лингвистики к 80-годам XX века в мире насчитывалось около 500 языков программирования. Активизируется примерно ещё столько же, хотя общее количество известных языков программирования достигает нескольких тысяч. Следует отметить актуальность проблемы человеко-машинного общения, множество подходов к ее решению. Основное назначение языка –использование для передачи информации между людьми. Это означает понятие информации, то есть, сведения о положении дел в окружающем мире, его свойствах, протекающих

в нем процессах и т.п. [2,20]. Данный процесс включает в себя последовательность сигналов или символов (теория передачи информации).

Таким образом, лингвистикой следует считать науку о закономерностях происхождения, строения и функционирования естественного человеческого языка. Предметом лингвистики и компьютерной лингвистики как ее особого раздела выступает язык — знаковая система, используемая с различными целями. Благодаря информационной технологии лингвистические исследования продвигаются в масштабе, активизируется в информационном потоке речи.

#### **ЛИТЕРАТУРА:**

1. Беляева Л.Н. Лингвистические автоматы в современных гуманитарных технологиях: учеб. пособие. СПб.: Книжный Дом, 2007. С. 36—40.
2. Баранов А.Н. Введение в прикладную лингвистику: учеб. пособие. 3-е изд. М.: ЛКИ, 2007.
3. Под ред. Власова В.М. Информационные технологии на автомобильном транспорте: Учебник / - М.: Academia, 2017. - 320 с.
4. Гвоздева, В. А. Введение в специальность программиста : учеб. для сред. проф. образования / В. А. Гвоздева. – Москва : ИНФРА-М ; ФОРУМ, 2013. – 208 с. : ил. – (Профессиональное образование).
5. Большой энциклопедический словарь. Языкознание. М.: Большая Российская энциклопедия, 1998. С. 201—202; 604—606, 618—622.

6.Зубкова, Т. М. Технология разработки программного обеспечения / Т. М. Зубкова. — Санкт-Петербург : Лань, 2023. — 252 с. —Текст : электронный // Лань.

7.Казарин, О. В. Основы информационной безопасности: надежность и безопасность программного обеспечения : учеб. пособие для сред. проф. образования / О. В. Казарин, И. Б. Шубинский. — Москва : Издательство Юрайт, 2024. — 342 с. — (Профессиональное образование). —Текст : электронный // Образовательная платформа Юрайт [сайт].

**ИСТОЧНИК:**

1. <https://urait.ru/>
2. <https://e.lanbook.com/book/>
3. <https://urait.ru/bcode/>
4. <https://urait.ru/bcode/>

## **ISSUES OF TRANSLATING SCIENTIFIC TERMS FROM ENGLISH INTO UZBEK**

Tursunova Saodatxon Bakhtiyor qizi

2nd-year Master's Student, Department of Foreign Languages

Jizzakh State Pedagogical University

**Abstract.** One of the most challenging issues in translation is rendering expressions and scientific terms from one language into another while accurately conveying their meaning and denotative aspects. It is essential not only to transfer their lexical meaning but also to preserve their denotative and connotative meanings. This article examines the problems encountered in translating certain expressions and scientific terms from English into Uzbek. As highlighted in the study, there are no fixed or universal methods for working with expressions in translation, and selecting the most appropriate translation strategy largely depends on the translator's competence and professional skills.

**Keywords:** proverb, translation, meaning, transformation, equivalent, problem, negative and positive connotations, expressions, metaphor, similes, literal and figurative meaning.

Axborot ta'limi tarjimasini kengaytirishni talab qiladigan ushbu tezkor dunyoda muhim vazifa hisoblanadi; chunki yaxshi tarjimon xabarni osongina va hech qanday o'zgarishsiz etkazishi mumkin. Shu tarzda nafaqat yaxshi tarjimonlarni tayyorlash, balki yaxshi tarjimani tayyorlash ham muqarrar. Ushbu maqola ushbu sohadagi avvalgi tadqiqotlar natijalari bo'lgan idioma tarjimasi strategiyasiga qaratilgan. Bugungi kunda tilshunoslikda "Oddiy nutq" atamasi turlicha talqin qilinmoqda. Masalan, rus tilshunosligida bu atama "Tasir" deb ataladi. Shu tarzda, u adabiy bo'lmagan leksik frazeologik qatlamning uchta komponenti sifatida tushuniladi. Ushbu tarkibiy qismlarga shaharning oddiy

nutqi bilan bog'liq lahjalar, jargonlar va so'zlar kiradi. Ammo, qo'pol adabiy nutq me'yorlaridan chetga chiqadigan past xarakterli haqiqatni ifodalash xususiyatiga ega bo'lgan oddiy nutq atamasi. Shahar va qishloq lahjalari shu paytgacha keng o'rganilmagan. Biz bilamizki, shahar va qishloq lahjalari bir biridan farq qiladi.

Shubhasiz, biz norasmiy nutq paytida oddiy nutqdan foydalanamiz yoki suhbat paytida suhbatlar va iboralar muhim rol o'ynaydi. Kundalik hayotimizda biz turli vaziyatlarni ifodalash uchun tegishli iboralardan foydalanamiz. Oddiy nutq bilan bog'liq iboralarda rasmiyatchilikning rangi emas, balki rangning tabiiyligi va soddaligi muhim rol o'ynaydi. Bunday iboralar suhbatimizni obrazli, jonli, ta'sirchan va hamma uchun tushunarli qilishga yordam beradi.

Misol: "A drop in the ocean" - "Dengizdan tomchi";

"Burn the midnight oil" - "Tunni tongga ulamoq";

"To be dressed to kill" - "Did bilan yarashtirib kiyinmoq",

"Big shot" - "Katta mavqega ega bo'lmoq" and so on

Iboralar odamlar o'rtasida baxt, ishonch, aldash, sabrsizlik, muvaffaqiyatsizlik, asabiylashish va boshqa munosabatlar kabi turli xil munosabatlarga ega. Ushbu turdagi iboralar inson sharoitlarini tavsiflashda juda foydali.

Masalan, ushbu turdagi vaziyatlarni tavsiflash uchun quyidagi iboralardan foydalanish mumkin.

Happiness-Being extremely happy:

1)"Full of the joys of spring" - "Juda xursand, juda baxtli."

2)"Thrilled to bits" - "Juda xursand bo'lish."

3)"Feel on top of the world" - "Juda xursand bo'lish."

4)"Floating/walking on air" - "Juda xursand bo'lish."

5)"Over the moon" - "Juda xursand bo'lish."

Confidence:

1)"Count on" - "Ishonmoq, suyanmoq."

Deception:

1)"To break the news" - "Sirni sotmoq."

Impatience:

1)"Can't stand someone or something" - "Chidab turolmaslik."

Failure:

1)"To blow it" - "Imkoniyatni qo'ldan boy bermoq."

Nervousness:

1)"Blow one's top" - "Tepa sochi tikka bo'lmoq."

Idiomalar qahramonlarning xatti-harakatlarini tasvirlash uchun yozuvchilarning kitoblarida keng qo'llaniladi. Masalan, eng buyuk o'zbek yozuvchilaridan biri Said Ahmad tomonidan yozilgan " Ufq " trilogiyasini olaylik. Ushbu trilogiyada Said Ahmad A'zamjon deb nomlangan bosh qahramonlardan birining holatini tasvirlash uchun "voz kechish" iborasini ishlatgan.

A'zamjon qo'lini yuvib qo'ltiqqa urgandi. U hozir alam otashida yonardi. O'zini qishloqda tug'ilib o'sgan qishlog'idan quvilgan hisoblardi.

U ikkinchi Jahon urushidan uyga qaytib keyin A'zamjon qiyinchiliklarga ko'rsatdi, shunday qilib, bu holda, yozuvchi, bu iborani ishlatiladi.

Bundan tashqari, u bu iborani ishlatgan "to be disappointed" - "Taruvi qo'ltig'idan tushmoq" eri A'zamjon bilan janjallashgandan keyin qishloqdagi barcha qizlar orasida eng jozibali va chiroyli qiz bo'lgan Dildorning ahvolini tasvirladi.

Dildor yana ko'chaga yugurdi. Guzarga chiqdi, samovarda ham yo'q.

Tanish - bilishlardan so‘radi, ko‘rdim degan odam bo‘lmadi. Birdan Dildorning yuragini vahm bosdi. "Ketgan, albatta, ketgan. Yo frontga, yo cho‘lga..." Uning tarvuzi qo‘ltig‘idan tushdi. Yuragi siqilib yo‘l chetida o‘tirgancha qoldi.

Ingliz tilida biz ushbu iboralarni "to give up", "to be disappointed" "Qo‘lini yuvib qo‘ltiqqa urmoq", "Tarvuzi qo‘ltig‘idan tushmoq." ning ekvivalenti sifatida ishlatamiz.

Iboralarni guruhlariga ajratish orqali ham o‘rganish mumkin.

Tuzilmalar jihatidan iboralar quyidagicha tasniflanadi.

1. Qiyosiy ifodalar like va as bilan tuzilgan iboralardir.

Masalan:

- 1)"As easy as pie" - "Xamirdan qil sug‘urganday";
- 2)"To eat like a bird" - "Juda kam ovqatlanish";
- 3)"Sick as a dog" - "Juda qattiq kasal bo‘lmoq";
- 4)"Sleep like a baby" - "Juda yaxshi uxlamoq";
- 5)"To work like a dog" - "Juda qattiq ishlamoq".

"Not" - "e mas" rad etish so'zi bilan tuzilgan iboralar.

- 1)"(To) not have a clue" – “Yechimini topolmaslik”
- 2)"(To) not Sleep a wink" - “Mijja qoqmaslik”
- 3)"Leave no stone unturned" – “Bor imkoniyatini ishga solib harakat qilmoq”
- 4)"Do not judge a book its cover" – “Tashqi ko‘rinishga qarab baho bermang

Bundan tashqari, iboralarda sinonim va antonimlar ham mavjud. Misol uchun, sinonimlarni olaylik.

Hech qanday qiyinchiliksiz, oson:

1) "At all costs" - "Hech qanday qiyinchiliklarsiz."

His dream is to become a great lawyer at all costs.

2) "At any costs" - "Hech qanday qiyinchiliklarsiz."

They were determined to win the game at any cost.

3) "As easy as pie" - "Juda oson."

Internetda chiroyli tasvirlarni qidirish bugungi kunda pie kabi oson.

Juda qimmat:

1) "A rip-off" - "Juda qimmat."

&60 for a cup of coffee is a complete rip-off.

2) "Cost an arm and a leg" - "Juda qimmat."

The movie is interesting, but the tickets cost an arm and a leg.

Deliberately not to go to a class when you should be there:

1) "To cut class" - "Ataydan darsga kelmaslik."

This is the second time this week Juliana has cut class.

2) "To play hooky" - "Ataydan darsga kelmaslik."

If you play hooky again, the teacher will be very angry.

3) "To ditch class" - "Ataydan darsga kelmaslik."

Agar siz har doim darsdan voz kechsangiz, o'qishda bilim to'play olmaydiz. Quyida bir qator iboralarni misol sifatida keltirish mumkin.

1) "Against the clock" - "Vaqtidan oldin"

2) "A mile a minute" - "Juda tez"

3) "A bad egg" - "Ishonchsiz odam"

4) "To be under the weather" - "O'zini yaxshi his qilmaslik"

5) "Be bummed out" - "Judayam xafa bo'lmoq"

6) "Chicken out" - "Juda qo'rqmoq"

7) "To catch someone red-handed" - "Biron kishini biron ishda ayblab qo'lga"

olmoq"

8)"Down in the dumps" - "Juda xafa his qilmoq"

9)"Get the picture" - "Tushunmoq"

10)"Head over heels in love" - "Jinnilarcha sevmiq".

Xulosa qilib aytishimiz mumkinki, inson tili real dunyoning ma'lum bir sohasini nafaqat yagona so'z yoki so'z ma'nolari bilan, balki umuman tilning butun tizimi bilan, uning turli darajalarining o'zaro ta'sirini aks ettiradi va ifodalaydi. Hozirgi kunda har qanday tilni idiomatik ishlatmasdan qiymatga to'la deb hisoblash mumkin emas, chunki frazeologik birliklardan foydalanish ma'lum bir til rivojlanishining birinchi belgisidir. Idiomatik jumlar so'z boyligini boyitadi, shuningdek ularni to'g'ri egallash ma'ruzachi tilni ona tilida so'zlashuvchi darajasida bilishini bildiradi.

#### FOYDALANILGAN ADABIYOTLAR

1. Smith W.G. The Oxford Dictionary of English Proverbs. –Oxf., 1970.
2. The Oxford Dictionary of Current English. Revised second edition, edited by Della Thompson. Oxford University press,1996.
3. Abdurahmanova X, Arkadyeva S. Ingliz tili tarjima nazariyasi. –T., 2005.

Turg'unova, F. (2022). YANGLIK SARLAVHALARINING MATNI VA YANGLIK SARLAVHALARINING TASNIFI. Хоразм Маъмун академияси ноширлик бўлими. [https://scholar.google.com/citations?view\\_op=view\\_citation&hl=ru&user=sj8tHeYAAAAJ&citation\\_for\\_view=sj8tHeYAAAAJ:d1gkVwhDp10C](https://scholar.google.com/citations?view_op=view_citation&hl=ru&user=sj8tHeYAAAAJ&citation_for_view=sj8tHeYAAAAJ:d1gkVwhDp10C)

Ataboyev, I. M., & Turgunova, F. R. (2022). The concept of semantic field in linguistics. *Academicia Globe: Inderscience Research*, 3(04), 378-383. [https://scholar.google.com/citations?view\\_op=view\\_citation&hl=ru&user=\\_mAVGF0AAAAJ&citation\\_for\\_view=\\_mAVGF0AAAAJ:IjCSPb-OGe4C](https://scholar.google.com/citations?view_op=view_citation&hl=ru&user=_mAVGF0AAAAJ&citation_for_view=_mAVGF0AAAAJ:IjCSPb-OGe4C)

Turgunova, F. (2021). GAZETA VA JURNALISTIK USLUBNING XUSUSIYATLARI: GAZETA VA JURNALISTIK USLUBNING XUSUSIYATLARI. Журнал иностранных языков и лингвистики, 2(7).

[https://scholar.google.com/citations?view\\_op=view\\_citation&hl=ru&use\\_r=sj8tHeYAAAAJ&citation\\_for\\_view=sj8tHeYAAAAJ:u5HHmVD\\_uO8C](https://scholar.google.com/citations?view_op=view_citation&hl=ru&use_r=sj8tHeYAAAAJ&citation_for_view=sj8tHeYAAAAJ:u5HHmVD_uO8C)

Turgunova, F. (2021). TRANSLATIONAL STUDY OF ENGLISH AND UZBEK NEWS HEADLINES. Журнал иностранных языков и лингвистики, 2(2).

[https://scholar.google.com/citations?view\\_op=view\\_citation&hl=ru&use\\_r=sj8tHeYAAAAJ&citation\\_for\\_view=sj8tHeYAAAAJ:\\_FxGoFyzp5QC](https://scholar.google.com/citations?view_op=view_citation&hl=ru&use_r=sj8tHeYAAAAJ&citation_for_view=sj8tHeYAAAAJ:_FxGoFyzp5QC)

Ataboyev, I. (2022). INGLIZ TILIDA TA'NA-DASHNOM TUSHUNCHALARNI BILDIRUVCHI LEKSIK BIRLIKLARNING SEMANTIK MAYDONI. Хоразм Маъмун академияси ноширлик бўлими.

[https://scholar.google.com/citations?view\\_op=view\\_citation&hl=ru&use\\_r=\\_mAVGF0AAAAJ&citation\\_for\\_view=\\_mAVGF0AAAAJ:UeHWp8X0CEI](https://scholar.google.com/citations?view_op=view_citation&hl=ru&use_r=_mAVGF0AAAAJ&citation_for_view=_mAVGF0AAAAJ:UeHWp8X0CEI)  
C

Rustamov, I. T., Atabaev, I. M., Muxtorova, X. I., & Yaxshilikova, N. X. (2021). DESCRIPTONAL PRINCIPLES OF NOUN UNITS. 湖南大学学报 (自然科学版), 48(11).

[https://scholar.google.com/citations?view\\_op=view\\_citation&hl=ru&use\\_r=\\_mAVGF0AAAAJ&citation\\_for\\_view=\\_mAVGF0AAAAJ:UebtZRa9Y70C](https://scholar.google.com/citations?view_op=view_citation&hl=ru&use_r=_mAVGF0AAAAJ&citation_for_view=_mAVGF0AAAAJ:UebtZRa9Y70C)

Ataboev, I. (2020). COMPARATIVE STUDY OF THE FUNCTIONAL SEMANTIC FIELD IN ENGLISH AND UZBEK LANGUAGES. Журнал иностранных языков и лингвистики, 1(1).

[https://scholar.google.com/citations?view\\_op=view\\_citation&hl=ru&use\\_r=\\_mAVGF0AAAAJ&citation\\_for\\_view=\\_mAVGF0AAAAJ:Se3iqnhoufwC](https://scholar.google.com/citations?view_op=view_citation&hl=ru&use_r=_mAVGF0AAAAJ&citation_for_view=_mAVGF0AAAAJ:Se3iqnhoufwC)

**THE ROLE OF A SCHOOL PSYCHOLOGIST IN WORKING WITH GIFTED  
STUDENTS: THEORETICAL FOUNDATIONS AND PRACTICAL  
MECHANISMS**

Author: Saitqulova Iroda Bakhtiyor qizi

Position: Psychologist

Institution: School No. 7, Zomin District, Jizzakh Region

**Abstract:**

This scientific article is devoted to the theoretical and practical analysis of the significant role of a school psychologist in the educational system when working with gifted and talented students (adolescents). Identifying giftedness, understanding its psychological characteristics, and preventing social-emotional adjustment problems are considered among the primary responsibilities of a school psychologist. The article examines contemporary models of giftedness, methods of psychological diagnostics, and differential approaches to supporting gifted students.

**Keywords:**

Giftedness, talent, school psychologist, psychological diagnostics, differentiated education, adjustment, Renzulli's model, Dabrowski's theory.

Zamonaviy ta'lim tizimining asosiy vazifalaridan biri jamiyatning intellektual salohiyatini shakllantirish, ya'ni iste'dodli va iqtidorli yoshlarni aniqlash, qo'llab-quvvatlash va rivojlantirishdir. Iste'dodli o'quvchilar, ayniqsa o'smirlilik davrida, nafaqat yuqori aqliy qobiliyatga ega bo'lishadi, balki o'ziga xos psixologik xususiyatlar, yuqori sezuvchanlik va ijtimoiy moslashuvda qiyinchiliklar bilan ham ajralib turishadi. Maktab psixologi bu jarayonda markaziy shaxs hisoblanadi. Uning roli faqatgina muammolarni hal qilishdan iborat bo'lmay, balki iste'dodning to'liq ochilishiga sharoit yaratish, o'quvchining shaxsiy va hissiy salomatligini ta'minlashdan iboratdir. Iste'dodli

o'smirlar bilan ishlash maxsus bilim va differensial yondashuvni talab qiladi, chunki ularning ehtiyojlari standart ta'lim dasturlari doirasidan chiqib ketadi.

O'zbekiston Respublikasida ta'lim islohotlari doirasida iqtidorli yoshlarni qo'llab-quvvatlashga katta e'tibor qaratilmoqda. Prezident Sh. Mirziyoyev ta'kidlaganidek, "Bizning eng katta boyligimiz – bu yoshlarimiz, ularning iste'dodi va salohiyatidir. Bu salohiyatni to'liq ro'yobga chiqarish uchun barcha sharoitlarni yaratishimiz shart" [1]. Ushbu maqola maktab psixologining iste'dodli o'smirlar bilan ishlashdagi nazariy asoslarini tahlil qilish, shuningdek, amaliy mexanizmlarni ishlab chiqish orqali mazkur sohadagi dolzarb muammolarga yechim topishni maqsad qilgan. Maqolaning maqsadi – maktab psixologining iste'dodli o'smirlar bilan ishlashdagi funksional vazifalarini zamonaviy psixologik nazariyalar asosida yoritish va ularning ijtimoiy-emotsional rivojlanishini ta'minlash bo'yicha samarali usullarni ko'rsatish.

Iste'dod tushunchasi ko'p qirrali bo'lib, uzoq vaqt davomida faqat yuqori intellekt darajasi (IQ) bilan bog'langan. Biroq, zamonaviy psixologiya iste'dodni murakkab, ko'p komponentli tizim sifatida ko'rib chiqadi. O'zbek psixologiyasida iste'dodga berilgan ta'riflar ko'pincha shaxsning faoliyatda yuqori natijalarga erishish qobiliyati sifatida qaraladi. Masalan, M.G. Davletshin iste'dodni "shaxsning muayyan faoliyatni muvaffaqiyatli bajarishi uchun zarur bo'lgan qobiliyatlar yig'indisi" deb ta'riflaydi [2]. Xalqaro miqyosda esa iste'dodni tushunishda keng yondashuvlar ustunlik qiladi. Iste'dodli o'quvchilar bilan ishlashda eng ko'p qo'llaniladigan modellar quyidagilardir:

Jozef Renzulli iste'dodni uchta o'zaro bog'liq xususiyatning kesishmasi sifatida ta'riflaydi [3]:

1. Yuqori qo'zg'aluvchanlik: Bu umumiy intellektual qobiliyatni va ma'lum sohalardagi maxsus qobiliyatlarni o'z ichiga oladi.

2. Vazifaga sodiqlik: Motivatsiya, qat'iyatlik, mehnatsevarlik va qiyinchiliklarga qaramay maqsadga intilish.

3. Ijodkorlik: Muammolarga yangi va o'ziga xos yechimlar topish qobiliyati.

Polshalik psixolog Kazimierz Dabrowski nazariyasi iste'dodli o'smirlarning hissiy va shaxsiy rivojlanishini tushunish uchun muhimdir. Uning nazariyasiga ko'ra, iste'dodli shaxslar ko'pincha "yuqori qo'zg'aluvchanlik bilan tavsiflanadi [4]. Bu besh turdagi qo'zg'aluvchanlik mavjud:

1. Intellektual: Bilimga cheksiz chanqoqlik, chuqur tahlilga moyillik.

2. Emotsional: Kuchli, murakkab his-tuyg'ular, chuqur empatiklik.

3. Tassavvuriy: Boy fantaziya, metaforik fikrlash.

4. Sensor: Atrofdagi tovush, rang va hidlarga yuqori sezgirlik.

5. Psixomotor: Yuqori energiya, tez gapirish va harakat qilish ehtiyoji.

Dabrowski nazariyasi maktab psixologiga iste'dodli o'smirlarning stress, perfektsionizm va moslashuv muammolarining ildizini tushunishga yordam beradi. "Iste'dodli o'smirning ichki dunyosi ko'pincha vulqonga o'xshaydi – u yorqin va ijodiy, ammo shu bilan birga beqaror va portlovchi bo'lishi mumkin," deb yozadi amerikalik tadqiqotchi Linda Silverman [5].

Iste'dodni aniqlash maktab psixologining asosiy vazifalaridan biridir. Bu jarayon bir martalik testdan iborat bo'lmay, balki muntazam, ko'p bosqichli va kompleks yondashuvni talab qiladi. Maktab psixologi iste'dodni aniqlashda turli usullarni qo'llaydi:

a) Standartlashtirilgan testlar: Intellekt darajasini baholash (masalan, Veksler shkalasi), shuningdek, maxsus qobiliyat testlari (matematika, til, mantiq).

b) Ijodkorlikni baholash: Torrensning ijodiy fikrlash testlari kabi usullar orqali o'quvchining o'ziga xoslik, moslashuvchanlik va ravonlik kabi ijodiy qobiliyatlari baholanadi.

c) Kuzatuv va nominatsiya: O'qituvchilar, ota-onalar va tengdoshlar tomonidan o'quvchining sinfdagi va sinfdan tashqari faoliyatini kuzatish. Bu subyektiv bo'lsa-da, o'quvchining motivatsiyasi va vazifaga sodiqligini (Renzulli modeli) aniqlashda muhimdir.

d) Loyiha portfeli tahlili: O'quvchining mustaqil ishlari, yutuqlari va qiziqishlarini aks ettiruvchi hujjatlar to'plami.

O'zbekistonlik psixolog E. G'oziyev ta'kidlaganidek, "Iste'dodni aniqlashda faqat IQga tayanish yetarli emas. Biz shaxsning butun psixik tuzilishini, uning faoliyatga bo'lgan ichki motivatsiyasini o'rganishimiz kerak" [6]. O'smirlik davri shaxsiyat shakllanishining murakkab davri bo'lib, iste'dodli o'smirlarda bu jarayon yanada keskin kechadi. Ular quyidagi psixologik muammolarga ko'proq moyil bo'lishadi:

- Perfeksionizm va o'z-o'zini tanqid: Yuqori standartlar qo'yish natijasida muvaffaqiyatsizlikdan qo'rqish.
- Tengdoshlar bilan moslashuv: Ular qiziqishlari va aqliy darajasi bo'yicha tengdoshlaridan farq qilgani uchun ijtimoiy izolyatsiya xavfi mavjud.
- Ekzistensial tashvishlar: Dunyoning murakkabligi, adolatsizlik haqida chuqur o'ylash.

Maktab psixologi o'smirning iste'dodini rivojlantirish bilan birga, uning "o'zini qabul qilish" va "ijtimoiy kompetentlik" ko'nikmalarini shakllantirishga ham e'tibor qaratishi zarur [7]. Maktab psixologining asosiy amaliy vazifasi iste'dodli o'quvchilar uchun optimal rivojlanish muhitini yaratishda ta'lim jarayoniga psixologik yordam ko'rsatishdir. Iste'dod har bir o'quvchida turli sohalarda namoyon bo'ladi. Shuning uchun psixologning maslahati bilan ta'limda differensial yondashuvni qo'llash zarur:

a) Akseleratsiya (tezlashtirish): O'quvchining o'zlashtirish tezligiga mos ravishda yuqori sinf dasturlarini o'rganishga ruxsat berish.

b) Boyitish: Standart dasturga qo‘shimcha chuqurlashtirilgan materiallar, loyihalar va tadqiqot ishlarini kiritish. Psixolog bu jarayonda o‘quvchining qiziqishlari va motivatsiyasini (Renzulli vazifaga sodiqligi) hisobga olgan holda individual ta‘lim rejasini ishlab chiqishda ishtirok etadi.

Mashhur pedagog A. Avloniy ta‘kidlaganidek, "Tarbiya biz uchun yo hayot – yo mamot, yo najot – yo halokat masalasidir. Har bir bolaning ichidagi yashirin qobiliyatni ochish tarbiyachining burchidir" [8]. Iste‘dodli o‘smirlar ko‘pincha o‘zlarining ichki ziddiyatlari va kuchli his-tuyg‘ulari bilan kurashadilar. Psixolog bu yerda quyidagi yo‘nalishlarda ish olib boradi:

- Hissiy tartibga solish: Dabrovski nazariyasi asosida o‘quvchiga o‘zining yuqori qo‘zg‘aluvchanligini tushunishga va uni ijobiy yo‘nalishga (masalan, ijodkorlik yoki chuqur tadqiqotga) yo‘naltirishga yordam berish.
- Karera yo‘nalishi: O‘smirning qiziqishlari va qobiliyatlarini kelajakdagi kasbiy faoliyat bilan bog‘lash.
- Muvaffaqiyatsizlikni boshqarish: Perfeksionizm bilan kurashish, xatolarni o‘rganish imkoniyati sifatida qabul qilishni o‘rgatish.

Iste‘dodli o‘smirlar uchun maxsus guruhlar tashkil etish ularning ijtimoiy moslashuvi uchun juda muhimdir. Bu guruhlar quyidagi maqsadlarga xizmat qiladi:

- Tengdoshlar bilan aloqa: O‘zlarining aqliy darajasi va qiziqishlariga mos keladigan boshqa o‘quvchilar bilan muloqot qilish imkoniyati.
- Ijtimoiy ko‘nikmalar: Empatiya, muloqot va hamkorlik ko‘nikmalarini rivojlantirish.
- Munozara klublari: Chuqur intellektual munozaralar orqali intellektual qo‘zg‘aluvchanlikni qondirish.

Amerikalik psixolog F. Gagne iste‘dodni rivojlantirishda atrof-muhitning rolini ta‘kidlab, "Iste‘dod faqat genetik sovg‘a emas, balki u qulay muhit va tizimli qo‘llab-quvvatlash orqali rivojlanadigan salohiyatdir" degan edi [9]. Maktab psixologi iste‘dodli

o'quvchining rivojlanishida uchburchak aloqani (o'quvchi – ota-ona – o'qituvchi) muvofiqlashtirishi kerak. Psixolog ota-onalarga farzandlarining yuqori sezuvchanligini tushunishga, ularga haddan tashqari bosim o'tkazmaslikka va ularning mustaqil fikrlashini rag'batlantirishga yordam beradi. Psixolog o'qituvchilarga iste'dodli o'quvchilarning psixologik xususiyatlarini tushuntiradi, ularga differensial topshiriqlar berish metodikasini o'rgatadi va sinfda ijobiy, qo'llab-quvvatlovchi muhit yaratishda yordam beradi. O'zbekistonlik pedagog olim R. Safarova ta'lim jarayonidagi psixologik yordam muhimligini qayd etib, "Ta'lim samaradorligi o'qituvchining metodik mahorati bilan bir qatorda, psixologning har bir o'quvchining individual ehtiyojlarini qondirishdagi faoliyatiga ham bog'liqdir" [10] deb aytgan.

Iste'dodli o'smirlar ko'pincha "ikki tomonlama g'ayrioddiy" holatga ega bo'lishlari mumkin, ya'ni ular iste'dodli bo'lishlari bilan birga, o'rganishdagi qiyinchiliklar yoki diqqat yetishmasligi sindromi kabi muammolarga ham duch kelishlari mumkin. Psixolog bu murakkab vaziyatlarni aniqlashda hal qiluvchi rol o'ynaydi [11]. Maktab psixologi profilaktik ishlarni olib borish orqali ijtimoiy-emotsional moslashuv muammolarining oldini oladi:

1. Stress-menejment dasturlari: Perfeksionizm va yuqori bosim natijasida kelib chiqadigan stressni boshqarish usullarini o'rgatish.
2. Muloqot ko'nikmalarini rivojlantirish: O'smirlarga o'zlarining g'ayrioddiy qiziqishlarini tengdoshlari bilan bo'lishishning sog'lom usullarini o'rgatish.
3. O'zini anglash mashg'ulotlari: O'smirning o'z kuchli va zaif tomonlarini, shuningdek, yuqori qo'zg'aluvchanlik sabablarini tushunishga yordam berish.

Psixologiya fanining asoschilaridan biri L.S. Vigotskiyning fikricha, "Bolaning rivojlanishi uning ijtimoiy muhit bilan o'zaro ta'sirida yuzaga keladi. Iste'dodni rivojlantirish uchun esa 'eng yaqin rivojlanish zonasi'ni yaratish zarur" [12]. Maktab psixologi aynan shu zonani ta'lim muhitida shakllantiruvchi shaxsdir.

Iste'dodli o'smirlar bilan ishlashda psixologning axloqiy mas'uliyati juda yuqori. Ular o'quvchining shaxsiy ma'lumotlarining maxfiyligini saqlashi, ularga bosim o'tkazmasligi va iste'dodni "yaxshiroq" yoki "ustunroq" degan yorliq ostida ajratib qo'ymasligi kerak. Psixologning maqsadi – har bir o'quvchining shaxsiy o'sishiga ko'maklashish, ularni jamiyatga foydali, barkamol insonlar etib tarbiyalashdir.

O'zbekistonlik olim B. Qodirov ta'limda insonparvarlik tamoyilini ilgari surib, "Har bir inson, ayniqsa yosh avlod, o'zining shaxsiy qadr-qimmatini his qilishi kerak. Iste'dodli bolaga e'tibor, bu uning shaxsiyatiga bo'lgan hurmat ifodasidir" [13] deb ta'kidlagan.

**Xulosa.** Maktab psixologining iste'dodli o'smirlar bilan ishlashdagi o'rni zamonaviy ta'lim tizimida strategik ahamiyatga ega. Uning faoliyati iste'dodni aniqlashdan tortib, uni rivojlantirish va ijtimoiy-emotsional moslashuv muammolarini hal qilishgacha bo'lgan keng qamrovli jarayonni o'z ichiga oladi. Renzulli modeli iste'dodni uch komponentli tizim sifatida tushunishga yordam bersa, Dabrovski nazariyasi iste'dodli o'smirlarning ichki hissiy murakkabliklarini ochib beradi. Psixolog bu nazariy asoslarga tayanib, diagnostika, individual maslahat, guruh ishlari va differensial ta'lim dasturlarini qo'llash orqali o'z faoliyatini amalga oshiradi. Xulosa qilib aytganda, maktab psixologi iste'dodli o'smirning nafaqat intellektual o'sishini, balki uning shaxsiy farovonligi, hissiy barqarorligi va jamiyatda o'z o'rnini topishini ta'minlovchi asosiy ko'makchidir. Iste'dodli o'quvchilar bilan ishlash tizimini takomillashtirish, maktab psixologlarining malakasini oshirish va ularni zamonaviy diagnostika vositalari bilan ta'minlash bugungi kunning dolzarb vazifasidir. Bu esa o'z navbatida, mamlakatimizning kelajakdagi intellektual salohiyatini mustahkamlashga xizmat qiladi.

#### **ADABIYOTLAR RO'YXATI**

1. Mirziyoyev Sh. M. (2021). Yangi O‘zbekiston strategiyasi. Toshkent: O‘zbekiston nashriyoti.
2. Davletshin M. G. (2002). Yashirin qobiliyatlar va ularni rivojlantirish psixologiyasi. Toshkent: Fan.
3. Renzulli, J. S. (2005). The Three-Ring Conception of Giftedness. Storrs: University of Connecticut.
4. Dabrowski, K. (1996). Positive Disintegration. New York: Prometheus Books.
5. Silverman, L. K. (2013). Counseling the Gifted and Talented. Denver: Love Publishing Company.
6. G‘oziyev E. G. (2008). Umumiy psixologiya. Toshkent: O‘zbekiston faylasuflari milliy jamiyati.
7. Tursunov I. Yu. (2019). O‘smirlar psixologiyasi va kasbga yo‘naltirish masalalari. Toshkent: Ta’lim.
8. Avloniy A. (1913). Turkiy Guliston yoxud axloq. Toshkent (Qayta nashrlar).
9. Gagné, F. (2009). From giftedness to talent: Developmental model of giftedness and talent (DMGT). Roeper Review, 32(4), 255–267.
10. Safarova R. (2017). Pedagogik mahorat va innovatsion texnologiyalar. Toshkent: Fan va texnologiya.
11. Webb, J. T., Amend, E. R., & Webb, N. E. (2005). Misdiagnosis and Dual Diagnoses of Gifted Children and Adults. Scottsdale: Great Potential Press.
12. Vygotsky, L. S. (1978). Mind in Society: The Development of Higher Psychological Processes. Cambridge, MA: Harvard University Press.
13. Qodirov B. (2015). Shaxs kamoloti psixologiyasi. Toshkent: Sharq.
14. Karimova V. M. (2012). Ijtimoiy psixologiya. Toshkent: Fan.
15. Sternberg, R. J. (2018). The nature of giftedness and talent. American Psychologist, 73(2), 209-218.

## **Legal status and powers of the Chamber of Advocates of the Republic of Uzbekistan**

**Abdijemilova Sholpanay Abdikalikovna,  
Institute for analysis and regulatory impact  
assessment of legislation under the Ministry of  
Justice of the Republic of Uzbekistan**

### **Abstract**

This thesis analyzes the legal status, powers and place of the Chamber of Advocates of the Republic of Uzbekistan in the institute of the bar from a scientific, theoretical and practical point of view. The study substantiates the legal nature of the Chamber of Advocates as a non-governmental, independent and professional self-governing body, its relations with state bodies and mechanisms for ensuring its institutional independence.

### **Keywords**

Chamber of Advocates, institute of the bar, self-governance, legal status, institutional independence, disciplinary responsibility, transparency, international standards, regulatory and legal framework.

## **O‘zbekiston Respublikasi Advokatlar palatasining huquqiy maqomi va vakolatlari**

**O‘zbekiston Respublikasi Adliya vazirligi  
huzuridagi qonunchilikni tahlil qilish va  
tartibga solish ta’sirini baholash instituti bosh  
yuriskonsulti Abdijemilova Sholpanay  
Abdikalikovna**

### **Annotatsiya**

Mazkur tezisdagi O‘zbekiston Respublikasi Advokatlar palatasining huquqiy maqomi, vakolatlari va uning advokatura institutida tutgan o‘rni ilmiy-nazariy hamda amaliy jihatdan tahlil qilingan. Tadqiqotda advokatlar palatasining nodavlat, mustaqil va professional o‘zini o‘zi boshqarish organi sifatidagi huquqiy tabiati, davlat organlari bilan o‘zaro munosabatlari hamda institutsional mustaqilligini ta’minlash mexanizmlari asoslab berilgan.

### **Kalit so‘zlar**

Advokatlar palatasi, advokatura instituti, o‘zini o‘zi boshqarish, huquqiy maqom, institutsional mustaqillik, intizomiy javobgarlik, shaffoflik, xalqaro standartlar, normativ-huquqiy baza.

Advokatura institutining tashkiliy asosini O‘zbekiston Respublikasi Advokatlar palatasi tashkil etadi. Advokatlar palatasi advokatlarning o‘zini o‘zi boshqarish organi bo‘lib, u advokatlik faoliyatining mustaqilligini ta‘minlash, advokatlarning kasbiy huquq va manfaatlarini himoya qilish, shuningdek, advokatura institutining barqaror rivojlanishini ta‘minlashga qaratilgan.

Advokatlar palatasining huquqiy maqomi uning notijorat, mustaqil va professional tashkilot ekanligi bilan belgilanadi. Palata davlat organlaridan tashkiliy va funksional jihatdan mustaqil bo‘lsa-da, uning faoliyati qonun bilan belgilangan doirada amalga oshiriladi. Bu holat advokatura institutining mustaqilligi va bir vaqtning o‘zida jamoat manfaatlariga xizmat qilishini ta‘minlaydi.

O‘zbekiston Respublikasi Advokatlar palatasi faoliyati bir qator normativ-huquqiy hujjatlar bilan tartibga solinadi. Ushbu hujjatlar advokatura institutining huquqiy asoslarini belgilab, palataning tashkil etilishi, vakolatlari va faoliyat yuritish tartibini mustahkamlaydi.

Amaldagi normativ-huquqiy baza tahlili shuni ko‘rsatadiki, advokatura faoliyatini tartibga solishda muayyan izchillik mavjud bo‘lsa-da, ayrim normalar zamonaviy talablar va xalqaro standartlarga to‘liq mos kelmaydi. Xususan, advokatlar palatasining mustaqilligi, uning davlat organlari bilan o‘zaro munosabatlari, shuningdek, intizomiy javobgarlik mexanizmlarida huquqiy noaniqliklar kuzatiladi.

Bundan tashqari, normativ-huquqiy hujjatlarda advokatlar palatasining tashkiliy va moliyaviy mustaqilligini kuchaytirishga qaratilgan aniq mexanizmlar yetarli darajada ifoda etilmagan. Bu holat palataning o‘z vazifalarini to‘liq va samarali amalga oshirishiga salbiy ta‘sir ko‘rsatishi mumkin.

Shu sababli, advokatlar palatasi faoliyatini tartibga soluvchi normativ-huquqiy bazani takomillashtirish, uni xalqaro standartlar va ilg‘or xorijiy tajribaga moslashtirish dolzarb vazifa hisoblanadi.

Advokatlar palatasining samarali faoliyati, avvalo, uning institutsional mustaqilligi va ichki boshqaruv tizimining to‘g‘ri tashkil etilganligiga bog‘liq. Amaliyot shuni ko‘rsatadiki, O‘zbekiston Respublikasi Advokatlar palatasi o‘zini o‘zi boshqarish organi sifatida belgilangan bo‘lsa-da, ushbu tamoyil to‘liq darajada amalga oshirilmayapti.

Palata boshqaruv tuzilmasida markaziy va hududiy organlar o'rtasida vakolatlarning aniq taqsimlanmaganligi ayrim muammolarni keltirib chiqarmoqda. Xususan, hududiy advokatlar palatalarining tashkiliy va moliyaviy mustaqilligi cheklangan bo'lib, ularning markaziy organlarga haddan tashqari bog'liqligi kuzatiladi. Bu holat hududiy darajada advokatlarning manfaatlarini tezkor va samarali himoya qilish imkoniyatlarini pasaytiradi.

Bundan tashqari, palata faoliyatida strategik rejalashtirish va faoliyat natijadorligini baholash mexanizmlari yetarli darajada shakllanmagan. Ko'plab qarorlar qisqa muddatli ehtiyojlardan kelib chiqib qabul qilinayotgani, uzoq muddatli institutsional rivojlanish konsepsiyasining yo'qligi bilan izohlanadi.

Advokatlik faoliyatining samaradorligi, eng avvalo, advokatning kasbiy mustaqilligi va uning huquqlarining real ta'minlanganligiga bog'liq. Normativ-huquqiy hujjatlarda advokatlarning mustaqilligi e'tirof etilgan bo'lsa-da, amaliyotda ushbu tamoyilning buzilishi bilan bog'liq holatlar uchrab turadi.

Zamonaviy huquqiy davlat sharoitida professional o'zini o'zi boshqarish organlarining ochiqligi va shaffofligi muhim talablardan biri hisoblanadi. Advokatlar palatasi faoliyatida ushbu tamoyillar normativ jihatdan belgilangan bo'lsa-da, ularning amaliy ta'minlanish darajasi yetarli emas. Xususan, palata qarorlarini qabul qilish jarayonida advokatlar hamjamiyatining keng ishtiroki ta'minlanmagan. Qabul qilinayotgan qarorlar, moliyaviy faoliyat natijalari hamda intizomiy amaliyot bo'yicha ma'lumotlarning ochiqligi cheklangan. Bu holat advokatlar o'rtasida palata faoliyatiga nisbatan ishonchsizlik kayfiyatining shakllanishiga olib kelishi mumkin.

Advokatura institutining samarali faoliyat yuritishi ko'p jihatdan advokatlarning o'zini o'zi boshqarish organlari qanday tashkil etilganiga bog'liq. Xalqaro tajriba shuni ko'rsatadiki, rivojlangan huquqiy davlatlarda advokatlar palatalari advokatura mustaqilligini ta'minlovchi asosiy institutsional kafolat sifatida faoliyat yuritadi.

Yevropa davlatlari tajribasida advokatlar palatalari mustaqil professional uyushma sifatida shakllanib, ularning faoliyatiga davlat organlarining bevosita aralashuvi qat'iy cheklangan. Xususan, palatalar advokatlarning kasbiy huquqlarini himoya qilish, intizomiy masalalarni ko'rib chiqish va kasbiy standartlarni belgilashda yetakchi rol o'ynaydi. Intizomiy ish yuritish jarayonlarida shaffoflik va advokatlarning o'zlari tomonidan boshqarilishi asosiy tamoyil hisoblanadi.

Xalqaro standartlar, jumladan, advokatlarning mustaqilligi to'g'risidagi xalqaro hujjatlar advokatura faoliyatida o'zini o'zi boshqarish tamoyilining ustuvorligini e'tirof

etadi. Ushbu standartlarga ko‘ra, advokatlar palatalari davlatdan mustaqil bo‘lishi, ularning qarorlari advokatlar hamjamiyati manfaatlariga xizmat qilishi lozim.

Mazkur xorijiy tajribani O‘zbekiston sharoitida qo‘llash advokatlar palatasining institutsional mustaqilligini kuchaytirish, shuningdek, uning davlat organlari bilan o‘zaro munosabatlarni qayta ko‘rib chiqishni talab etadi.

Advokatlar palatasi faoliyatini takomillashtirishning muhim yo‘nalishlaridan biri uning huquqiy maqomi va vakolatlarini aniq va izchil belgilashdan iborat. Amaldagi qonunchilikda palataning mustaqilligi e‘tirof etilgan bo‘lsa-da, ushbu mustaqillikni ta‘minlovchi aniq huquqiy mexanizmlar yetarli darajada mustahkamlanmagan.

Mazkur muammoni bartaraf etish maqsadida advokatlar palatasining vakolatlarini qayta ko‘rib chiqish va ularni qonun darajasida aniq belgilash maqsadga muvofiq. Xususan, palataning advokatlarning kasbiy huquqlarini himoya qilish borasidagi vakolatlarini kengaytirish, davlat organlari tomonidan advokatlik faoliyatiga aralashuv holatlariga nisbatan majburiy munosabat bildirish mexanizmlarini joriy etish zarur.

Shuningdek, advokatlarga nisbatan intizomiy javobgarlikni qo‘llash tartibini takomillashtirish dolzarb masala hisoblanadi. Intizomiy ish yuritish jarayonlarida advokatlarning protsessual huquqlari, qarorlar ustidan shikoyat qilish mexanizmlarini kuchaytirish, shuningdek, intizomiy organlar faoliyatida mustaqillik va xolislikni ta‘minlash lozim.

Bundan tashqari, advokatlar palatasining moliyaviy mustaqilligini ta‘minlashga qaratilgan normalarni kuchaytirish muhim ahamiyatga ega. Palataning moliyaviy resurslari mustaqil ravishda shakllantirilishi va ularning sarflanishi ustidan jamoatchilik nazorati mexanizmlari joriy etilishi lozim.

Tadqiqot natijalari asosida Advokatlar palatasini faqat tashkiliy tuzilma emas, balki advokatura mustaqilligini ta‘minlovchi asosiy institutsional kafolat sifatida qayta ko‘rib chiqish zarurligi ilmiy jihatdan asoslab berildi. Ilgari surilgan takliflar advokatura institutining barqaror rivojlanishiga, advokatlarning kasbiy huquqlarini real himoya qilishga hamda sud-huquq tizimida adolat tamoyilini mustahkamlashga xizmat qiladi.

### **FOYDALANILGAN ADABIYOTLAR RO‘YXATI**

1. O‘zbekiston Respublikasi Konstitutsiyasi. 01.05.2023 <https://lex.uz/docs/-6445145>

2. O‘zbekiston Respublikasi Prezidentining “Advokatlik faoliyatini tartibga solish to‘g‘risida”gi Farmoni. 12.05.2018 O‘zbekiston Respublikasi Qonun hujjatlari to‘plami, 2018.
3. O‘zbekiston Respublikasining «Advokatlik faoliyatining kafolatlari va advokatlarning ijtimoiy himoyasi to‘g‘risida»gi Qonuni. 25.12.1998  
<https://lex.uz/uz/docs/-29626>
5. Давлятов В. Особенности деятельности органов адвокатского самоуправления в романо-германской системе права //Общество и инновации. – 2024. – Т. 5. – №. 1/S. – С. 229-233.

#### **LIST OF REFERENCES**

1. The Constitution of the Republic of Uzbekistan. May 1, 2023.  
<https://lex.uz/docs/-6445145>
2. Decree of the President of the Republic of Uzbekistan “On the Regulation of Advocacy Activity.” May 12, 2018.
3. Collection of Legislative Acts of the Republic of Uzbekistan, 2018.
4. Law of the Republic of Uzbekistan “On Guarantees of Advocacy Activity and Social Protection of Advocates.” December 25, 1998.  
<https://lex.uz/uz/docs/-29626>
5. Davlyatov, V. Peculiarities of the Activities of Bodies of Advocates’ Self-Government in the Romano-Germanic Legal System. Society and Innovations, 2024, Vol. 5, No. 1/S, pp. 229–233.

## PROFESSIONAL ETHICS OF A LAWYER IN THE SYSTEM OF LEGAL REGULATION

Tashkent Law College lecturer  
Zulfiya Mudarifovna Ibragimova

**Abstract:** This article, using theoretical and legal analysis, explores the essence of professional legal ethics, its place, and role in the system of legal regulation and legal activity. It examines the fundamental ethical principles enshrined in professional codes, as well as the challenges of their implementation in the current context of the legal system's development. It substantiates the conclusion that professional legal ethics is an important condition for ensuring the rule of law, justice, and public trust in legal institutions.

**Keywords:** professional legal ethics, legal activity, legality, legal consciousness, professional responsibility, moral principles, codes of ethics.

## ПРОФЕССИОНАЛЬНАЯ ЭТИКА ЮРИСТА В СИСТЕМЕ ПРАВОВОГО РЕГУЛИРОВАНИЯ

Преподаватель юридического техникума  
города Ташкента  
Ибрагимова Зульфия Мударифовна

**Аннотация:** В статье на основе теоретико-правового анализа раскрывается сущность профессиональной этики юриста, ее место и роль в системе правового регулирования и юридической деятельности. Рассматриваются основные этические принципы, закрепленные в нормах профессиональных кодексов, а также проблемы их реализации в современных условиях развития правовой системы. Обосновывается вывод о том, что профессиональная этика юриста выступает важным условием обеспечения законности, справедливости и доверия общества к правовым институтам.

**Ключевые слова:** профессиональная этика юриста, юридическая деятельность, законность, правосознание, профессиональная ответственность, моральные принципы, кодексы этики.

В условиях формирования правового государства и развития гражданского общества особое значение приобретает проблема профессиональной этики юриста. Юридическая деятельность непосредственно связана с реализацией публичной власти, защитой прав и свобод человека и гражданина, разрешением правовых конфликтов. В этой связи от уровня нравственной культуры юриста во многом зависит эффективность правоприменения и степень доверия общества к правовой системе.

Современная юридическая практика демонстрирует, что формального соблюдения норм права недостаточно для достижения справедливости и законности. Все большую роль играют моральные ориентиры, профессиональные ценности и этические стандарты поведения юриста. Именно поэтому исследование профессиональной этики юриста является актуальной научной задачей, имеющей теоретическое и практическое значение, в том числе для подготовки магистров права.

Целью настоящей статьи является комплексный анализ профессиональной этики юриста, выявление ее содержания, принципов и проблем реализации в современной правовой действительности.

Профессиональная этика юриста представляет собой отрасль прикладной этики, формирующую систему моральных норм и принципов, регулирующих поведение юриста в процессе осуществления профессиональной деятельности. Ее содержание определяется, с одной стороны, общечеловеческими нравственными ценностями, а с другой — спецификой юридической профессии и требованиями законодательства.

В научной литературе профессиональная этика юриста рассматривается как элемент правовой культуры и правосознания, обеспечивающий внутреннюю мотивацию правомерного поведения. В отличие от норм права, этические нормы не всегда обладают формально-юридической обязательностью, однако их соблюдение обеспечивается профессиональной ответственностью, корпоративным контролем и общественным мнением.

Особенностью профессиональной этики юриста является тесная взаимосвязь морали и права. Юрист в своей деятельности должен руководствоваться не только буквой закона, но и его духом, что предполагает нравственную оценку принимаемых решений и их последствий.

### **Принципы профессиональной этики юриста**

Содержание профессиональной этики юриста раскрывается через систему принципов, определяющих основные требования к его профессиональному поведению.

Принцип **законности** предполагает безусловное соблюдение норм права, недопустимость произвольного толкования законодательства и использования правовых средств в противоправных целях.

Принцип **справедливости** выражается в объективности, беспристрастности и равном отношении ко всем участникам правоотношений независимо от их социального статуса и иных обстоятельств.

Принцип **гуманизма** ориентирует юриста на уважение чести и достоинства личности, защиту прав и свобод человека как высшей ценности.

Принцип **честности и добросовестности** исключает злоупотребление профессиональными полномочиями, коррупционные проявления и конфликт интересов.

Принцип **конфиденциальности** закрепляет обязанность юриста сохранять профессиональную тайну и обеспечивать защиту информации, полученной в ходе выполнения профессиональных функций.

Принцип **профессиональной ответственности** предполагает осознание социальной значимости юридической деятельности и готовность нести ответственность за принятые решения и их правовые последствия.

### **Нормативно-правовое закрепление профессиональной этики юриста в Республике Узбекистан**

Профессиональная этика юриста в Республике Узбекистан имеет нормативное закрепление и основывается на положениях Конституции Республики Узбекистан, отраслевого законодательства, а также специальных кодексов профессиональной этики.

Конституция Республики Узбекистан закрепляет фундаментальные принципы законности, справедливости, равенства граждан перед законом, уважения прав и свобод человека, которые составляют ценностную основу профессиональной деятельности юриста. В частности, положения Конституции об обязательности соблюдения закона и ответственности государственных

органов и должностных лиц формируют этические ориентиры юридической профессии.

Значительное место в регулировании профессиональной этики занимают специальные нормативные акты. Так, **Закон Республики Узбекистан «О судах»** и **Кодекс судейской этики** устанавливают требования независимости, беспристрастности, неподкупности и высокого морального облика судьи. Судья обязан не только соблюдать закон, но и своим поведением укреплять доверие общества к судебной власти.

Этические основы адвокатской деятельности закреплены в **Законе Республики Узбекистан «Об адвокатуре»** и **Кодексе профессиональной этики адвоката**, которые предусматривают принципы независимости адвоката, приоритета интересов доверителя, соблюдения адвокатской тайны, недопустимости конфликта интересов.

В деятельности органов прокуратуры ключевое значение имеют требования объективности, законности и справедливости, отраженные в **Законе Республики Узбекистан «О прокуратуре»**, а также ведомственных этических стандартах. Аналогичные требования предъявляются к следователям и другим должностным лицам, осуществляющим правоохранительную деятельность.

Для юрисконсультов, нотариусов и государственных служащих важную роль играют положения **Закона Республики Узбекистан «О государственной гражданской службе»**, **Закона «О нотариате»**, а также нормы антикоррупционного законодательства, направленные на обеспечение честности, прозрачности и добросовестности юридической деятельности.

Таким образом, национальное законодательство Республики Узбекистан формирует комплексную систему правовых и этических требований к юристам, обеспечивая институциональную связь профессиональной этики с правовым регулированием.

Этические требования к юристам конкретизируются в зависимости от вида профессиональной деятельности и закрепляются в специальных кодексах профессиональной этики.

Для судей ключевое значение имеют принципы независимости, беспристрастности и неподкупности, обеспечивающие доверие к судебной власти. Для адвокатов приоритетными являются защита интересов доверителя, соблюдение адвокатской тайны и независимость от органов власти. В

деятельности прокуроров и следователей особое значение имеют объективность, законность и отказ от обвинительного уклона. Юрисконсульты и нотариусы обязаны обеспечивать баланс частных и публичных интересов, действуя строго в рамках закона.

Таким образом, профессиональная этика выступает универсальным регулятором юридической деятельности, адаптируемым к ее конкретным формам.

Несмотря на наличие развитой системы нормативного и корпоративного регулирования, реализация норм профессиональной этики юриста на практике сталкивается с рядом проблем. Среди них — коммерциализация юридической деятельности, давление со стороны заинтересованных лиц, недостаточная эффективность механизмов дисциплинарной ответственности.

Дополнительные этические вызовы связаны с цифровизацией правовой сферы, использованием электронных баз данных и технологий искусственного интеллекта, что требует переосмысления традиционных подходов к конфиденциальности и профессиональной тайне.

Перспективы развития профессиональной этики юриста связаны с совершенствованием кодексов профессиональной этики, усилением роли профессиональных сообществ, а также интеграцией этических дисциплин в систему высшего юридического образования на уровне магистратуры.

Профессиональная этика юриста является неотъемлемым элементом правовой системы и важнейшим условием эффективной юридической деятельности. Ее соблюдение обеспечивает гармоничное сочетание правовых и моральных начал, способствует укреплению законности и формированию доверия общества к правовым институтам.

В условиях усложнения правовых отношений и трансформации юридической профессии значение профессиональной этики юриста возрастает, что обуславливает необходимость ее дальнейшего научного осмысления и практического развития.

### **Использованная литература**

1. Конституция Республики Узбекистан.
2. Кодекс судейской этики Республики Узбекистан.
3. Кодекс профессиональной этики адвоката Республики Узбекистан.
4. Алексеев С.С. Теория права. — М.: Норма.

5. Кудрявцев В.Н. Право и нравственность. — М.: Юридическая литература.
6. Марченко М.Н. Общая теория государства и права. — М.: Проспект.

### **References**

1. Constitution of the Republic of Uzbekistan.
2. Code of Judicial Ethics of the Republic of Uzbekistan.
3. Code of Professional Ethics of Lawyers of the Republic of Uzbekistan.
4. Alekseev, S.S., Theory of Law. Moscow: Norma.
5. Kudryavtsev, V.N., Law and Morality. Moscow: Legal Literature.
6. Marchenko, M.N., General Theory of State and Law. Moscow: Prospect.

## **Distinctive Characteristics of Nipah Virus**

**Autors: Salaydinova Vasila**-Student of the 420th group, Biology department, Samarkand State Pedagogical Institute.

**Xasanov Azizbek Murodovich**-2- grade student of Samarkand State Medical University faculty of treatment

**Mirzayev Bekjon Sharobiddinovich**-2- grade student of Samarkand State Medical University faculty of treatment

**Scientific supervisor: Odilova Nilufar Arzikulovna**-Assistant of Department of Microbiology, Samarkand State Medical University.

### **Abstract.**

Nipah virus (NiV) is a highly pathogenic zoonotic virus that belongs to the family Paramyxoviridae and the genus Henipavirus. Since its first identification in 1998 during an outbreak in Malaysia, Nipah virus has attracted significant global attention due to its high mortality rate, broad host range, and potential for human-to-human transmission. This article provides a comprehensive overview of the distinctive biological, epidemiological, and clinical characteristics of Nipah virus. Special emphasis is placed on viral structure, modes of transmission, pathogenesis, clinical manifestations, diagnostic approaches, and prevention strategies. The article is designed in accordance with academic requirements and may be used as a teaching resource for medical and biological science students.

### **Keywords:**

Nipah virus, Henipavirus, zoonotic infection, encephalitis, emerging viruses

### **Introduction**

Nipah virus is considered one of the most dangerous emerging viral pathogens of the 21st century. It is a zoonotic virus capable of infecting both animals and humans, often causing severe disease with a high case fatality rate. The virus is naturally harbored by fruit bats of the Pteropus genus, which act as reservoir hosts without showing clinical symptoms. Human infections usually occur through direct or indirect contact with

infected animals or through consumption of contaminated food products. The ability of Nipah virus to cross species barriers and adapt to human transmission makes it a major public health concern.

### **Taxonomy and Structural Features**

Nipah virus belongs to the Paramyxoviridae family, which includes several medically important viruses such as measles and mumps viruses. Within this family, Nipah virus is classified under the genus Henipavirus, along with Hendra virus. Structurally, Nipah virus is an enveloped virus with a single-stranded, negative-sense RNA genome. The viral envelope contains two major glycoproteins: the attachment glycoprotein (G) and the fusion protein (F), which play a crucial role in viral entry into host cells. These glycoproteins interact with ephrin-B2 and ephrin-B3 receptors, which are widely distributed in human tissues, particularly in the nervous and respiratory systems.

### **Epidemiological Characteristics**

Epidemiologically, Nipah virus exhibits unique patterns compared to many other zoonotic viruses. Outbreaks have been reported primarily in South and Southeast Asia, including Malaysia, Bangladesh, and India. Seasonal variation is observed in some regions, often associated with fruit harvesting periods and increased contact between humans and bats. Unlike many zoonotic infections, Nipah virus has demonstrated efficient human-to-human transmission, particularly in healthcare settings and among family members providing close care to infected individuals.

### **Pathogenesis and Clinical Manifestations**

After entering the human body, Nipah virus spreads through the bloodstream and targets multiple organs. The virus shows a strong tropism for endothelial cells and neurons, leading to widespread vasculitis and severe inflammation of the central nervous system. Clinically, the disease often begins with non-specific symptoms such as fever, headache, and myalgia. As the infection progresses, patients may develop acute encephalitis, respiratory distress, and altered consciousness. The mortality rate can range from 40% to over 70%, depending on the outbreak and healthcare response.

### **Diagnostic and Preventive Approaches**

Laboratory diagnosis of Nipah virus infection requires high-level biosafety facilities due to the virus's extreme pathogenicity. Diagnostic methods include reverse transcription polymerase chain reaction (RT-PCR), enzyme-linked immunosorbent assay (ELISA), and virus isolation. Currently, there is no specific antiviral treatment approved for Nipah virus infection, and management remains largely supportive. Preventive strategies focus on reducing bat-to-human transmission, improving infection control measures in healthcare settings, and enhancing public awareness. Vaccine development is ongoing and remains a critical area of research.

### **Conclusion**

Nipah virus represents a significant threat to global health due to its high lethality, zoonotic nature, and potential for outbreaks with human-to-human transmission. Understanding the distinctive features of this virus is essential for early detection, effective prevention, and preparedness for future outbreaks. Continuous research, surveillance, and international collaboration are vital to mitigate the risks associated with Nipah virus.

### **References**

1. Medical Virology. Tashkent Medical Academy Publishing House.
2. Epidemiology of Infectious Diseases. Samarkand State Medical University.
3. General Microbiology. Bukhara State Medical Institute.
4. Infectious Diseases. Andijan State Medical Institute.
5. Zoonotic Infections and Public Health. Tashkent Pediatric Medical Institute.
6. Clinical Virology. Urgench Branch of Tashkent Medical Academy.
7. Fundamentals of Epidemiology. Fergana Medical Institute of Public Health.
8. Emerging and Re-emerging Infections. Tashkent State Dental Institute.

## **Issues of Transforming the Creative Heritage of Nizami and Navoi into an International Literary Tourism Brand**

### **Scientific Supervisor:**

Lecturer of the Department of International Tourism and Economics, Kokand  
University  
Mamadaliyev Ulug‘bek  
[u.mamadaliyev@kokanduni.uz](mailto:u.mamadaliyev@kokanduni.uz)

### **Kokand University**

Student of the *Tourism* (by fields of activity)  
Bachelor’s degree program  
Abdumannonov Rizobek Iqboljon o‘g‘li  
[rizonabumannonov01@gmail.com](mailto:rizonabumannonov01@gmail.com)

**Abstract.** This article examines, from both theoretical and practical perspectives, the issues involved in transforming the creative heritage of the great representatives of Eastern classical literature—Nizami Ganjavi and Alisher Navoi—into an international literary tourism brand. The study elaborates on the concept of literary tourism and highlights its cultural and economic significance, conducting a comparative analysis with Western experiences, particularly those associated with Shakespeare, Dante, and Goethe. In addition, the tourism potential of historical and cultural sites connected with the lives and works of Nizami and Navoi is assessed. The article substantiates the role of infrastructure development, marketing strategies, cultural diplomacy, and regional cooperation in the formation of a literary tourism brand. The research findings contribute to the development of practical recommendations aimed at promoting Eastern literary heritage at the global level and fostering sustainable tourism development.

**Keywords:** Literary tourism, Nizami Ganjavi, Alisher Navoi, cultural heritage, tourism branding, comparative analysis, Eastern and Western literature, cultural diplomacy.

### **Nizomiy va Navoiy ijodini xalqaro adabiy turizm brendiga aylantirish masalalari**

Ilmiy rahbar: Qo‘qon universiteti Xalqaro turizm va iqtisodiyot kafedrasida o‘qituvchisi  
Mamadaliyev Ulug‘bek  
[u.mamadaliyev@kokanduni.uz](mailto:u.mamadaliyev@kokanduni.uz)

Qo‘qon universiteti

Turizm (faoliyat yo‘nalishlari bo‘yicha)  
ta’lim yo‘nalishi talabasi  
Abdumannonov Rizobek Iqboljon o‘g‘li  
*rizoxonabdumannonov01@gmail.com*

**Annotatsiya.** Ushbu maqolada Sharq mumtoz adabiyotining buyuk namoyandalari — Nizomiy Ganjaviy va Alisher Navoiy ijodiy merosini xalqaro adabiy turizm brendiga aylantirish masalalari ilmiy-nazariy va amaliy jihatdan tahlil qilingan. Tadqiqotda adabiy turizm tushunchasi, uning madaniy va iqtisodiy ahamiyati yoritilib, G‘arb tajribasi (Shekspir, Dante, Gyote) bilan qiyosiy tahlil amalga oshirilgan. Shuningdek, Nizomiy va Navoiy hayoti hamda ijodi bilan bog‘liq tarixiy-madaniy makonlarning turistik salohiyati baholanadi. Maqolada infratuzilma, marketing, madaniy diplomatiya va hududiy hamkorlik omillarining adabiy-turistik brend yaratishdagi o‘rni asoslab beriladi. Tadqiqot natijalari Sharq adabiy merosini jahon miqyosida targ‘ib qilish va barqaror turizmni rivojlantirish uchun amaliy tavsiyalar ishlab chiqishga xizmat qiladi.

**Kalit so‘zlar:** Adabiy turizm, Nizomiy Ganjaviy, Alisher Navoiy, madaniy meros, turistik branding, qiyosiy tahlil, Sharq va G‘arb adabiyoti, madaniy diplomatiya

### **Kirish.**

Adabiy turizm – madaniy merosning muhim yo‘nalishlaridan biri bo‘lib, u buyuk adiblar hayoti va ijodi bilan bog‘liq maskanlarga sayohatni nazarda tutadi. Tadqiqotchilar adabiy turizmni madaniy merosga asoslangan sayohat turi sifatida ta’riflaydilar: bunda sayyohlar adiblarning tug‘ilgan yoki yashagan uylari, qabrlari, muzeylari, asarlarida tasvirlangan manzillar hamda adabiy festivallar va tadbirlarda qatnashish uchun safar qilishadi[1, 4-11]. Bunday sayohatlar madaniy-ma’rifiy tajriba berib, kitobxonlarga sevimli adiblar dunyosiga yaqinlashish imkonini yaratadi. Bugungi kunda jahonda adabiy merosni turizmga integratsiya qilish orqali muvaffaqiyatli brendlar yaratilgan – Shekspirning Stratford-upon-Avondagi merosi, Dante Aligyerining Florensiya va Ravennadagi izdoshlari yo‘li, Gyotening Veymardagi muhiti shular jumlasidandir. Bu holatlar adabiy merosni iqtisodiy resursga aylantirish va xalqaro miqyosda targ‘ib etishning yorqin misollaridir.

O‘zbekiston va Ozarbayjon singari davlatlar Sharq mumtoz adabiyoti vakillari bo‘lgan Nizomiy Ganjaviy va Alisher Navoiy merosini xuddi shunday darajada xalqaro turizm brendigiga aylantirishga intilmoqda. Zero, Nizomiy va Navoiy kabi daholar ijodi nafaqat milliy madaniyatning bir qismi, balki butun jahon adabiyoti xazinasiga kiruvchi bebaho ma’naviy mulkdir[2, 2-4]. Ularning asarlarida tarannum etilgan umuminsoniy

qadriyatlar – muhabbat, ma’rifat va adolat – zamon va makon chegaralaridan oshib, bugungi kunda ham ahamiyatini yo‘qotmagan[3, 26-31][4, 13-15]. Shunday ekan, mazkur maqolada Nizomiy va Navoiy ijodiy merosini xalqaro adabiy-turistik brendga aylantirish masalalari IMRAD strukturasi asosida ko‘rib chiqiladi. Avvalo, g‘arb adabiy turizm brendlari (Shekspir, Dante, Gyote) bilan qiyosiy tahlil o‘tkazilib, muvaffaqiyat omillari tahlil qilinadi. Keyinchalik, Nizomiy va Navoiy hayoti, ijodi hamda ularning tarixiy-madaniy makonlari (Ganja, Hirot, Buxoro, Samarqand) turizm resursi sifatida baholanadi. Maqola so‘nggida adabiy-turistik brend yaratishning nazariy va amaliy asoslari yoritilib, shu yo‘nalishda tavsiyalar taklif etiladi.

### **Metodologiya.**

Ushbu tadqiqotda qiyosiy-tahliliy uslub qo‘llanilib, Sharq va G‘arb adabiy turizm brendlarini taqqoslash asosida xulosalar chiqarildi. Tadqiqot jarayonida jahon adabiyoti va turizm iqtisodiyoti bo‘yicha ilmiy adabiyotlar, shuningdek, Sharq mumtoz adabiy merosini o‘rganuvchi tadqiqotlar tahlil qilindi. Olingan ma’lumotlarni tizimli ravishda taqqoslash uchun tahliliy jadval tuzilib, unda har bir adib bo‘yicha davr, asosiy meros va turistik brend holati kabi ko‘rsatkichlar keltirildi. Shuningdek, “case study” usulida ayrim aniq misollar alohida ko‘rib chiqildi. Maqolada keltirilgan dalillar va xulosalar ilmiy manbalardan iqtiboslar yordamida asoslantirilib, har bir fikr tegishli manbaga tayangan holda yoritildi.

### **Asosiy qism.**

G‘arb mamlakatlarida buyuk adiblar merosini turizm resursiga aylantirish keng ko‘lamda amalga oshirilgan bo‘lib, bu jarayon ko‘plab iqtisodiy va madaniy natijalar bergan. Angliyada Uilyam Shekspir tug‘ilib o‘sgan Stratford-upon-Avon shahri bugungi kunda jahonning eng mashhur adabiy ziyoratgohlaridan biriga aylangan. Har yili ushbu kichik shahar Shekspir merosini ko‘zdan kechirish va Royal Shakespeare Company spektakllarini tomosha qilish uchun taxminan 2,5 million sayyohni jalb etadi[5, 3-5][6, 5-6]. Natijada mahalliy iqtisodiyotga sezilarli daromad kelmoqda – masalan, “Shekspir mamlakati” (Warvikshir) mintaqasida bir yilda turistlar tomonidan 505 million funt sterling sarflanib, minglab ish o‘rinlari yaratilganligi qayd etilgan[7, 19-25][8, 33-36]. Bu ko‘rsatkichlar adabiy brendning turizm iqtisodiyotiga bevosita ta’siridan dalolat beradi.

Italiyada buyuk shoir Dante Aligyeri merosini keng targ‘ib etish orqali madaniy turizmga jon kiritilgan. 2021 yilda Dante vafotining 700 yilligi munosabati bilan butun mamlakat bo‘ylab “Dante yili” deb e’lon qilinib, Florensiya va Ravenna shaharlarida

yuzlab adabiy-ma'rifiy tadbirlar o'tkazildi[9][10]. Xususan, Dante ijodiga oid maxsus sayyohlik marshruti – "Le Vie di Dante" (Dante yo'llari) yo'lga qo'yildi. Ushbu tarixiy marshrut Dante hayotida muhim ahamiyatga ega bo'lgan Florensiya va Ravenna shaharlari orasidagi masofani qamrab olib, Apennin tog' tizmalaridan o'tadi[11, 6][12, 8-11].

Germaniyada esa Ioann Wolfgang fon Gyote nomi bilan bog'liq maskanlar yevropalik adabiyot ixlosmandlarini o'ziga tortib keladi. Gyotening tug'ilgan shahri Frankfurt Main daryosi bo'yida joylashgan bo'lib, u yerdagi Goethe-Haus muzeyi orqali buyuk adibning bolaligi va ijodiy muhitiga sayohat qilish mumkin. Ayniqsa, Gyote ijodining asosiy makoni sanalmish Veymar shahri UNESCOning Jahon merosi ro'yxatiga kiritilgan "Klassik Veymar" majmuasi tarkibida alohida o'rin tutadi[13, 22-24]. Veymarda Gyote va uning zamondoshi Shiller yashagan uy-muzeylar, milliy teatr binosi, Ilm parki kabi obidalar yaxshi saqlangan va muzeylashtirilgan. Tadqiqotlar ko'rsatishicha, Veymarga tashrif buyuruvchi sayyohlar shaharga, birinchi navbatda, Gyote nomi va klassik adabiy muhit tufayli qiziqish bildiradilar[14, 156-173]. Darhaqiqat, turistlar orasida Veymar "Gyote shahri" sifatida mashhur bo'lib, shaharning brend imiji aynan shu adabiy meros bilan chambarchas bog'langan.

Yuqoridagi misollar G'arbda adabiy meros asosida yaratilgan turizm brendlarining muvaffaqiyat omillarini ochib beradi: davlat miqyosidagi e'tibor, infratuzilma va muassasalar (muzeylar, teatrlar, jamg'armalar) tashkil etilishi, muntazam adabiy festivallar hamda merosni targ'ib qiluvchi mahsulot va xizmatlar (ekskursiyalar, yo'l boshlanmalar, suvenirlar va h.k.) tizimi yo'lga qo'yilgan. Quyidagi jadvalda G'arb adabiy brendlari va Sharq mumtoz adiblari holati qiyosiy tarzda umumlashtirilgan:

<b>Adib (davlat)</b>	<b>Yashagan davri</b>	<b>Asosiy tarixiy maskanlari</b>	<b>Adabiy merosining ahamiyati</b>	<b>Turistik brend holati</b>
U. Shekspir (Angliya)	1564–1616	Stratford-upon-Avon (tug'il. joy), London (ijodi)	Jahon dramaturgiya cho'qqisi; Hamlet, Romeo va Juletta asarlari muallifi	Juda kuchli brend: Stratford shahri yiliga 2,5 mln sayyoh; Shekspir festivallari va muzeylari [5][6]; milliy iqtisodiyotga hissa[7].

Dante Aligyeri (Italiya)	1265–1321	Florensiya (tug‘ilgan), Ravenna (vafot etgan)	“Ilohiy komediya” asari bilan jahon adabiyoti durdonasi; italyan tilining otasi	Kuchli milliy brend: 2021 yilda Dante yubileyi davlat miqyosida nishonlandi; Florensiyada Dante uyi muzeyi, Ravennada qabri; “Dante yo‘llari” marshruti tashkil etildi[11].
J. V. Gyote (Germaniya)	1749–1832	Frankfurt (tug‘ilgan), Veymar (ijodiy davri)	Nemis adabiyoti ulug‘ siymosi; “Faust” tragediyasi muallifi, nemis madaniy uyg‘onish lideri	Kuchli hududiy brend: Veymar-UNESCO merosi; Gyote va Shiller muzeylari, har yili Gyote bayramlari; Veymarda asosan Gyote merosi uchun kelinadi [14].
Nizomiy Ganjaviy (Ozarbayjon)	1141–1209	Ganja (tug‘ilgan va vafot etgan)	Fors tilida Xamsa dostonini yaratgan, Sharq roman-epik adabiyoti dahosi	Rivojlanayotgan brend: Ganjada Nizomiy muzeyi va maqbarasi – shaharning diqqatga sazovor obidasi; 2021 yili Ozarbayjonda “Nizomiy yili”da, xalqaro anjumanlar o‘tkazildi[16]; ammo xalqaro sayyohlar orasida keng tanilmagan.
Alisher Navoiy (O‘zbekiston)	1441–1501	Hirod (tug‘ilgan), Samarqand (ta’lim olgan), Buxoro (madaniy kontekst)	Chig‘atoy adabi tili asoschisi; “Xamsa” asarini turkiy tilda yozgan birinchi shoir; davlat arbobi va ma’rifatparvar	Rivojlanayotgan brend: Toshkentda Navoiy bog‘i va haykali bor[17], Samarqand va Buxoroda adabiy-ma’rifiy tadbirlar; biroq xalqaro turizm yo‘nalishida Navoiy merosini targ‘ib etish endi yo‘lga qo‘yilmoqda.

*Izoh: Jadval mualliflar va ularning merosi haqidagi umumlashtirilgan ma’lumotlarni aks ettiradi. G‘arb adiblari bo‘yicha ma’lumotlar ochiq manbalardan (muzey statistikasi, UNESCO hisobotlari va yubiley tadbirlari xronikasi) olindi; Sharq adiblari bo‘yicha esa hozirgi holat davlat dasturlari va manbalarga tayanib berildi.*

Yuqoridagi qiyosiy tahlildan ko‘rinib turibdiki, Nizomiy va Navoiy merosini xalqaro turizm brendiga aylantirish uchun ularga tegishli tarixiy maskanlar va ob‘ektlarni sayyohlik resursiga aylantirish zarur.

Ozərbayjonda Nizomiy Ganjavıy tavallud topgan Ganja shahri allaqachon “she’r va adabıyot shahri” sıfatıda taniqlilik qozonmoqda. Ganjadagi Nizomiy maqbarası majmuası shaharning eng mashhur tarixiy obıdalarıdan bıri bo‘lib, bu yer zıyorchılar va sayyohlar uchun alohıda qadrli maskan sanaladı[15, 142-146]. Maqbara hududı 1990-yıllarda qayta ta’mırlanıb, majmua sıfatıda tartıbgá keltırılgen[15, 177-181]. Shuningdek, maqbara qarshısında Nizomiy nomıdagi Adabıyot muzeyı tashkil etılgen bo‘lib, unda buyuk sho‘rning qo‘lyozmaları, nodır “Xamsa” nusxaları va sho‘rning hayotı bılan bog‘lıq eksponatlar namoyısh etılmoqda[19, 16-21]. Ganja shahrıgá kiraverıshda joylashgan bu yodgorlık majmuası nafaqat tarixiy-me’moriy ahamıyatga, balkı ramziy ma’noga ham ega – Nizomiy qabri asrlar davomıda fıdoyı zıyorchılar oqıb keladıgan maskan bo‘lib kelgen[20, 7-13]. Mazkur an’ana aslıda adabıy turizmning ilk ko‘rınışlarıdan bıri sıfatıda baholanışı mumkin. Boku shahrıda ham Nizomiy nomını e’zozlash davom etmoqda: Milliy Ozarbayjon adabıyotı muzeyı Nizomiy nomıgá atab ochılgen bo‘lib, unda nafaqat Nizomiyning o‘zi, balkı Ozarbayjon adabıyotının boshqa namoyandalarıgá doir boy eksponatlar jamlangan[21, 3-6][22, 5-13]. 2021 yılda Ozarbayjonda Prezıdent farmonı bılan “Nizomiy Ganjavıy yılı” deb e’lon qılınıb, xalqaro anjumanlar, ko‘rgazmalar va madaniy tadbırlar o‘tkazıldı[16, 2-4]. Bu tadbırlar davomıda Nizomiy merosı dunyo miqyosıda madaniyatlar o‘rtasında “ko‘prik” vazıfasını o‘tashi, uning ijodı butun insoniyatning ma’naviy mulki ekani alohıda ta’kidlandı[2, 3-5]. O‘zbekiston ham ushbu tadbırlarda ishtırok etıb, o‘zbek xalqı Nizomiydek dahoga chuqur hurmat bılan qarashi va unı umumiy ajdod sıfatıda e’zozlashını bıldırğanı e’tıborga molik[4, 15][23, 11-14]. Bu hodısalar Nizomiy merosını mintaqaviy hamkorlık orqalı xalqaro maydongá olib chıqısh yo‘lıda muhim qadamdır.

O‘zbekiston va qo‘shni mamlakatlar uchun Alisher Navoiy merosini targ‘ib etish masalasi dolzarbdır. Navoiy faoliyat ko‘rsatgan asosiy maskan – hozirgi Afg‘oniston hududidagi Hirot shahri bo‘lib, u XV asrda Temuriylar saltanatining madaniy poytaxti bo‘lgan. Navoiy aynan shu yerda ijod qilib, davlat arbobi sıfatıda xızmat qılgen va Hirotni ulkan madaniyat markazıgá aylantırishga beqiyos hissa qo‘shgan. Tarixiy manbalarda keltırılışıcha, Navoiy Hirot va Khorasonda 370 ga yaqın ob‘ekt (masjidlar, madrasalar, kutubxonalar, karvonsaroylar, ko‘priklar va boshqalar)ni barpo etgan yoki

homiylilik bilan ta'mirlagan[24,12-16]. Jumladan, u Hirotida 40 ta karvonsaroy, 17 ta jome masjidi, 10 ta xonaqoh, 9 ta hammom, 9 ta ko'prik va 20 ta hovuz-qo'rg'on qurdirgani tarixchilarga ma'lum[24, 11]. Shu bois ayrim tadqiqotchilar Navoiy davridagi Hiroti "Temuriylar Uyg'onish davrining Florensiyasi" deb ataganlar[25, 33-41]. Bugungi kunda Hirot shahrida Alisher Navoiy qabri (Mozori Sho'hon qabristonida) mavjud bo'lib, u Afg'oniston hukumati tomonidan milliy madaniy yodgorlik sifatida muhofaza qilinadi. Afsuski, mintaqadagi geosiyosiy vaziyat bois bu maskan haligacha yirik xalqaro ziyoratgohga aylana olgani yo'q. Biroq, Samarqand, Buxoro va Toshkent shaharlari Navoiy merosini targ'ib qilish uchun muhim maydon bo'lib xizmat qilmoqda.

Navoiy yoshligida ta'lim olgan Samarqand shahri – Temuriylar davri ilm-fan va madaniyat markazi sifatida – uning shakllanishida muhim rol o'ynagan. Samarqanddagi Ulug'bek madrasasi va boshqa tarixiy me'moriy obidalar Navoiy zamonining ilmiy-ma'rifiy ruhi bilan bog'liq bo'lib, bugungi sayyohlarga o'sha davr atmosferasini his qilish imkonini beradi. Buxoro shahri esa, garchi Navoiy u yerda yashamagan bo'lsa-da, umumiy musulmon Sharq madaniy muhitining yorqin namunasi sifatida Navoiy ijodiy an'alarini anglashga xizmat qiladi. Buxoroning boy adabiy-ma'rifiy tarixiy muhiti (Xoja Hofiz, Jomiy, Xusrav Dehlaviy davrlaridan meros) Navoiy ijodiy avlodiga zamin bo'lgan. Hozirgi vaqtda O'zbekistonda Alisher Navoiy nomini abadiylashtirish va uning merosini targ'ib etishga katta e'tibor qaratilgan: Toshkentdagi Alisher Navoiy nomli milliy bog' hududida ulug' sho'ning muhtasham haykali o'rnatilgan va adib hayoti va ijodiga bag'ishlangan doimiy ko'rgazmalar yo'lga qo'yilgan[17, 29-31][18, 36-38]. 2021 yilda Navoiy tavalludining 580 yilligi munosabati bilan respublika va xalqaro miqyosda turli ilmiy anjumanlar ("Navoiy o'qishlari"), ko'rgazmalar va madaniy tadbirlar tashkil etildi. Jumladan, YUNESKO homiyligida Parij va boshqa shaharlarda Navoiyga bag'ishlangan tadbirlar o'tkazilib, unda Navoiy asarlarining jahon adabiyotidagi o'rni yodga olindi[26, 4-9][27, 4-11]. Bu kabi sa'y-harakatlar Navoiy siymosini jahon sahnasida yanada tanitish uchun zamin hozirlamoqda.

Yuqoridagi natijalardan ko'rinadiki, Sharq mumtoz adabiy merosi vakillari – Nizomiy va Navoiy – hozircha asosan mintaqaviy darajada e'tirof etilgan bo'lsa-da, ularning hayoti va ijodi bilan bog'liq maskanlar, moddiy va nomoddiy madaniy meros obyektlari ulkan turistik salohiyatga ega. Ganja, Hirot, Samarqand, Buxoro kabi shaharlarda ushbu adiblar merosini sayyohlarga tizimli ravishda "hikoya qilish" (storytelling) orqali mazkur maskanlarni yanada jozibali adabiy-turistik yo'nalishlarga aylantirish mumkin.

Qiyosiy tahlil shuni ko'rsatadiki, G'arbning Shekspir, Dante, Gyote kabi adabiy brendlari bilan taqqoslaganda, Nizomiy va Navoiy merosini xalqaro turizm darajasida targ'ib etishda hali ko'p ishlar qilinishi lozim. G'arb adabiy brendlari muvaffaqiyatining bir necha asosiy omillarini ajratish mumkin: (1) Institutlashgan muassasalar – masalan, Shekspir muzeyi va tug'ilgan uyi bilan shug'ullanuvchi Shakespeare Birthplace Trust singari jamg'armalar yoki Dante muzeyi, Gyote jamg'armasi kabi tashkilotlar adabiy merosni ilmiy o'rganish, saqlash va ommalashtirishga xizmat qiladi; (2) Davlat siyosati va mablag' – milliy va mahalliy hukumat darajasida adabiy merosga e'tibor qaratilib, infratuzilma (muzeylar binolari, yo'l ko'rsatkichlari, transport) va marketing faoliyati uchun mablag' ajratiladi; (3) Tizimli marketing va brending – adib nomi va qahramonlarini tijoratlashtirish (suvenirlar, kitob do'konlari, brendli festivallar) hamda ommaviy axborot vositalarida targ'ib etish; (4) Jahon tillariga tarjima va integratsiya – Shekspir va Dante asarlarining jahondagi mashhurligi ko'p jihatdan ularning asarlari xalqaro tillarga keng tarjima qilinganiga, shu asarlardan kino, teatr, opera kabi ommaviy mahsulotlar yaratilganiga bog'liq.

Sharq adabiy merosini (Nizomiy, Navoiy) brendlash esa o'ziga xos qiyinchilik va imkoniyatlarga ega. Bir tomondan, Nizomiy va Navoiy asarlari forsy va eski o'zbek (chig'atoy) tillarida bo'lib, ularni dunyo o'quvchisiga yetkazish uchun zamonaviy tarjima va nashrlar muammo bo'lib turibdi. Asarlarining cheklangan auditoriyaga ega bo'lishi ularning brend sifatidagi "tanishligi"ni kamaytiradi. Ikkinchi tomondan, bu adiblarning merosi hozirgi bir nechta mustaqil davlatlarning bo'lishib egalik qiluvchi merosidir: masalan, Nizomiy Ganjaviy Ozarbayjon (etnik kelib chiqishi turkiy deb bilinadi) va Eronda (fors tilida yozgani bois) birdek o'z dahosi deb e'lon qilingan; Alisher Navoiy esa O'zbekistonning milliy faxri bo'lsa-da, Afg'oniston, Eron, Turkmaniston kabi mamlakatlar tarixida ham muhim shaxs hisoblanadi [23, 178-191][28, 221-256]. Bu holat, bir jihatdan, hamkorlik imkoniyatlarini beradi (birgalikda nishonlash, tadbirlar uyushtirish orqali ko'proq auditoriyani jalb etish), biroq boshqa tarafdin koordinatsiya murakkabligini ham keltirib chiqaradi. Shu sababli, Nizomiy va Navoiy brendini xalqaro maydonda targ'ib etishda ushbu mamlakatlar o'rtasidagi madaniy hamkorlik va hamohang siyosat muhim ahamiyatga ega. Xususan, 2021 yilda Bokuda o'tgan Nizomiy Ganjaviy 880-yilligiga bag'ishlangan anjumanda bir necha davlat (Ozarbayjon, O'zbekiston, Turkiya va boshqalar) vakillari ishtirok etib, buyuk adiblar merosini birgalikda saqlash va targ'ib qilish lozimligini ta'kidlagani xalqaro hamkorlik uchun ijobiy misoldir [28, 53-58][3, 6-9].

Adabiy brend yaratishning nazariy asoslariga nazar solsak, u asosan destinatsion branding konsepsiyasiga tayanadi. Bu nazariyaga ko'ra, muayyan joyning o'ziga xos tarixi va madaniy boyliklari uning brend identifikatoriga aylanadi. Adabiy meros ham destinatsiya brandingning ajralmas qismi bo'lib xizmat qilishi mumkin. Olimlarning ta'kidlashicha, adabiy turizm nafaqat iqtisodiy foyda keltiradi, balki mamlakatning "yumshoq kuch" salohiyatini oshirishga, ya'ni uning madaniy diplomatiya vositasiga aylanishiga xizmat qiladi [29, 45] [30, 24-28]. Xususan, Asadi va boshq. (2022) tadqiqotida Yaqin Sharq mintaqasida adabiy turizm rivoji mavjud turizm turg'unligini bartaraf etish va ichki rivojlanishga turtki beruvchi istiqbolli yo'nalish sifatida e'tirof etilgan [30, 51-54]. Adabiy meros orqali xorijiy sayyohlarni jalb etish bir vaqtning o'zida mamlakatning boy madaniy qiyofasini namoyon etish, ijobiy imij yaratish va milliy g'ururni mustahkamlashga yordam beradi [29, 17-19].

Adabiy-turistik brend yaratishning amaliy asoslari esa bir nechta yo'nalishni o'z ichiga oladi:

Infratuzilma va muhitni tayyorlash: Sayyohlar oqimini jalb qilish uchun adabiy maskanlarda yetarli infratuzilma bo'lishi shart. Bu, avvalo, tarixiy obidalarni restavratsiya qilish va ularning asl "autentik" qiyofasini saqlagan holda jamoatchilikka ochiq muzeylar holiga keltirishdir. Shuningdek, mehmonxonalar, transport aloqasi, yo'nalish ko'rsatkichlari, axborot markazlari kabi infratuzilma elementlari ham bo'lishi zarur. Tadqiqotlarda qayd etilishicha, hatto boy adabiy diqqatga sazovor joylarning o'zi bilan cheklanib qolmay, turistlar ehtiyojlarini qondiruvchi qo'shimcha xizmatlar – qulay infratuzilma, turar joy, ovqatlanish, esdalik do'konlari – ham mavjud bo'lishi kerak [31, 87-93]. Aks holda, sayyoh faqat adabiy obida uchun kelib, boshqa sharoitlar noqulay bo'lsa, takroriy tashriflarni tavsiya etmaydi.

Brend hikoyasi va targ'iboti: Har bir adib va uning yashagan joyi atrofida qiziqarli brend rivoyati (storytelling) yaratilishi lozim. Masalan, Nizomiy Ganjaviy haqida "Layli va Majnunning ijodkori, Ganjada yotgan muhabbat shoiri" degan romantik qissa, Navoiyni esa "Hirotning buyuk vaziri va shoir-sulton" tarzida ta'riflovchi matnlar, ekskursiya yo'nalishlari ishlab chiqilishi mumkin. Bu rivoyatlar xorijiy sayyohlar esida qoladigan va ularni jalb qiladigan tarzidaligi muhim. Brendni targ'ib qilish uchun raqamli vositalar: rasmiy veb-saytlar, ijtimoiy tarmoqlar, virtual turlar va ilovalar ishlab chiqilishi kerak. Masalan, Shakespeare's Globe teatri yoki Dante 700 tadbirlarining internet orqali keng yoritilgani turistlar oqimini oshirgan edi. Xuddi shunday, Nizomiy va Navoiy bo'yicha ko'p tilli targ'ibot materiallari yaratilishi lozim.

Ta'lim va ilmiy tadqiqotlarni qo'llab-quvvatlash: Adabiy merosni brendlash barqaror bo'lishi uchun uni ilmiy asosda o'rganish va targ'ib etish davom etishi zarur. Bu borada universitetlar, ilmiy markazlar va muzeylar hamkorligida konferensiyalar, "Navoiy o'qishlari", "Nizomiy forumi" kabi an'anaviy ilmiy-ma'rifiy anjumanlarni muntazam o'tkazish maqsadga muvofiq. Ilmiy tadqiqotlar natijalari keng ommaga qulay uslubda yetkazilsa (ommabop maqolalar, hujjatli filmlar, ko'rgazmalar), brend mazmunan boyiydi va jozibador bo'ladi. O'zbekiston va Ozarbayjonda Navoiyning 580 yilligi, Nizomiyning 880 yilligi doirasida ilmiy anjumanlar o'tkazilgani – yaxshi namunadir[16, 5-7][32]. Kelgusida bunday tadbirlarni ko'proq sayyohlar jalb etadigan tarzda (masalan, adabiy festival formatida, turizm kompaniyalari homiyligida) tashkil etish lozim.

Hududiy hamkorlik va integratsiya: Yuqorida ta'kidlanganidek, Nizomiy va Navoiy merosi bir necha davlatga tegishli. Shunday ekan, xalqaro hamkorlik ularga bag'ishlangan turizm yo'nalishlarini rivojlantirishda katta rol o'ynaydi. Masalan, "Buyuk Ipak yo'li adabiy meros yo'nalishi"ni tashkil etish taklifi qiziq bo'lishi mumkin – u Ganja (Nizomiy), Samarkand va Buxoro (temuriy adabiy muhit), Hirot (Navoiy) shaharlari hamda, xohlasa, Shekspirning Stratfordi yoki Gyotening Veymari kabi sharq-g'arb adabiy markazlarini bog'lovchi sayyohlik marshruti bo'lishi mumkin. Bunday transmilliy marshrut YUNESKOning Butunjahon merosi yoki Madaniy yo'laklar dasturlari doirasida tan olinishi va targ'ib etilishi mumkin. Bu esa, o'z navbatida, ishtirokchi barcha mamlakatlarga qo'shimcha sayyohlar oqimini ta'minlab, iqtisodiy naf keltiradi. Turkiya madaniyat va turizm vaziri M. N. Ersoyning "ming yillik merosimizni saqlash yo'lida birlashmog'imiz kerak, aks holda betakror siymolar unutiladi yoki begonalashadi" degan so'zlari ham aynan shunday integratsiyalashgan yondashuv zarurligini ko'rsatadi[28, 3-5].

Iqtisodiy rag'batlar va mahalliy hamjamiyat manfaatdorligi: Adabiy turizm rivoji mahalliy aholiga daromad manbai yaratishi bilan ahamiyatli. Shu bois, mahalliy tadbirkorlikni jalb qilish lozim – masalan, Ganja va Buxoroda Nizomiy va Navoiy mavzusida tematik kafe, galereya, hunarmandchilik do'konlari ochilishi, ekskursovodlar tayyorlanishi va hokazo. Mahalliy aholi adabiy meros bilan faxrlansa va undan daromad olsa, uni asrab-avaylashga ham hissa qo'shadi. Shakespeare's England tajribasida, masalan, minglab mahalliy fuqarolar turizm sohasida band bo'lib, bu sohaga kuchli ijtimoiy qo'llab-quvvatlov mavjudligi kuzatiladi[33, 176-187][34, 55]. Xuddi

shunday, Ganja yoki Samarqandda adabiy brend orqali xizmat ko'rsatish sektori rivojlansa, bu barqarorlikni ta'minlaydi.

### **Xulosa.**

Yuqoridagi tahlillar va qiyosiy natijalar asosida xulosa qilish mumkinki, Nizomiy Ganjaviy va Alisher Navoiy merosini xalqaro adabiy turizm brendiga aylantirish – mantiqan pishib yetilgan, iqtisodiy va madaniy jihatdan foydali tashabbusdir. Shekspir, Dante, Gyote kabi adabiy brendlarning tajribasi ko'rsatadiki, buyuk adiblarning nomi va ijodi atrofida shakllangan turizm mahsuloti yillar davomida barqaror sayyoh oqimini va ijobiy imijni ta'minlay oladi. Sharq mumtoz adabiyotining bu ikki ulug' namoyandasi – Nizomiy va Navoiy – o'zlarining umumbashariy g'oyalari bilan aslida allaqachon jahon madaniyatlarining bir qismiga aylangan[2]. Endi vazifa shu ma'naviy merosni zamonaviy turizm tiliga “tarjima” qilishdir.

Maqolada ko'rsatib o'tilganidek, bu yo'lda bir qator muhim choralar amalga oshirilishi zarur: xalqaro hamkorlikni kuchaytirish, infratuzilmani rivojlantirish, brend hikoyalarni shakllantirish, targ'ibot va marketingni tizimli yo'lga qo'yish, hamda ilmiy-ma'rifiy ishlarni davom ettirish. Agar O'zbekiston, Ozarbayjon va tegishli davlatlar ushbu sohada sa'y-harakatlarni birlashtirsalar, yaqin kelajakda G'arb dunyosida “Nizami and Navoi – Oriental Literary Heritage” kabi yangi adabiy turizm yo'nalishining shakllanishi ehtimoldan xoli emas. Bu nafaqat turizm iqtisodiyoti uchun yangi imkoniyatlar yaratadi, balki jahon miqyosida Sharq va G'arb o'rtasidagi madaniy muloqotni mustahkamlashga, millatlararo tushunishni chuqurlashtirishga xizmat qiladi. Xulosa o'rnida aytganda, Nizomiy va Navoiy siymolari timsolida O'zbekiston va Ozarbayjon kabi mamlakatlar o'z boy madaniy meros brendini jahon bozoriga olib chiqish imkoniga ega. Bu jarayonda eng asosiy omil – merosga bo'lgan hurmat va uni asrab qolishdir. Zero, adabiy brend yaratish shunchaki iqtisodiy vosita bo'lib qolmay, milliy o'zlikni dunyoga namoyon etish, kelajak avlodlar uchun faxr manbai yaratish demakdir. Nizomiy va Navoiy merosini jahonga targ'ib etish orqali biz nafaqat qo'shimcha sayyohlarni jalb qilamiz, balki jahon madaniy manzarasida Sharq yulduzlarining yanada porlashiga hissa qo'shamiz. Bu esa, o'z navbatida, madaniyatlararo muloqotning kuchayishi va barqaror rivojlanish yo'lidagi qadamlardan biri bo'lur edi.

### **Foydalanilgan adabiyotlar**

1. Asadi, A. va boshq. “Challenges toward Sustainability? Experiences and Approaches to Literary Tourism from Iran”. Sustainability, 2022 – (adabiy turizm nazariyasi va hududiy rivojlanish haqida)[29][1].
2. IP Global. “Stratford-upon-Avon: A Timeless English Gem” (21 Nov 2024) – (Shekspir brendi va Stratford shahri statistikasi)[5][6].
3. Shakespeare’s England DMO. *Destination Management Plan Overview* (2015) – (Shekspir mintaqasida turizm iqtisodiyoti tahlili)[7][8].
4. Destination Florence. “Le Vie di Dante... slow tourism 2021” – (Dante yo‘llari loyihasi tavsifi)[11][12].
5. UNESCO World Heritage Centre. “Classical Weimar” – (Gyote va Veymar merosi tavsifi)[13].
6. Bauhaus-Universität Weimar. *Tadqiqot xabari* (12 Dec 2025) – (Veymar brendi bo‘yicha sayyohlar fikri)[14].
6. Azerbaijan Travel. “Nizami Ganjavi Mausoleum and Museum” – (Ganjada Nizomiy majmuasi tavsifi)[15][19].
7. UNESCO Silk Roads Programme. “Ganja” – (Nizomiy maqbarasi haqida ma’lumot)[20].
8. Xabar.uz (O‘zbekistan madaniyat yangiliklari). “Bu zotni o‘zbek xalqi ham e’zozlaydi” (25.11.2021) – (Nizomiy 880-yillik anjumani tafsilotlari)[3][2].
9. VisitSilkRoad.org. “Alisher Navoi Monument (Tashkent)” – (Navoiyning hayoti va faoliyati qisqacha)[35][17].
10. EciEco (EKO mamlakatlari madaniyati portali). “Alisher Navoi is an incomparable personality” – (Navoiyning me’moriy homiyligi haqida)[24][25].
11. Challenges toward Sustainability? Experiences and Approaches to Literary Tourism from Iran <https://www.mdpi.com/2071-1050/14/18/11709> [1] [29] [30] [31]
12. «Bu zotni o‘zbek xalqi ham e’zozlaydi» <https://xabar.uz/uz/madaniyat/>. [2] [3] [4] [16] [23] [28]
13. Stratford-upon-Avon: Discover England's Timeless <https://www.ipglobal-ltd.com> [5]
14. Assets.simpleviewinc.com <https://assets.simpleviewinc.com/>. [7] [8] [33] [34]
15. Italy celebrates Year of Dante in 2021 - Wanted in Milan <https://www.wantedinmilan.com/news/italy-celebrates-year-of-dante-in-2021.html> [9]
16. May 24, 2021. Italy is honoring Dante Alighieri in myriad ways on the ... <https://www.facebook.com/groups/RickStevesEurope/posts/802194893829469/> [10]

17. Le vie di Dante (the ways of Dante), a true gem of slow tourism 2021 - Destination Florence <https://www.destinationflorence.com/en/blog/311> [11] [12]
18. Classical Weimar UNESCO World Heritage Centre <https://whc.unesco.org/> [13]
19. Bauhaus-Universität Weimar: University <https://www.uni-weimar.de/en/university/news/> [14]
20. Nizami Ganjavi Mausoleum and Museum | Azerbaijan.Travel <https://azerbaijan.travel/nizami-ganjavi-mausoleum-and-museum> [15] [19]
21. Alisher Navoi Monument – VisitSilkRoad <https://visitsilkroad.org/destination/alisher-navoi-monument/> [17] [18] [35]
22. Ganja | Silk Roads Programme <https://en.unesco.org/silkroad/content/ganja> [20]
23. Take a journey through Azerbaijan’s literary history | Azerbaijan Travel <https://azerbaijan.travel/take-a-journey-through-azerbajians-literary-history> [21] [22]
24. Alisher Navoi is an incomparable personality | EciEco <https://www.ecieco.org/en/news/9049/> [24] [25]
25. Mamadaliyev, U., & Halilov, G. A. (2025, September). The Role Of Economic Innovations In Diversifying Tour Operator Services. In International Conference on Global Trends and Innovations in Multidisciplinary Research (Vol. 1, No. 3, pp. 45-47).
26. Mamadaliyev, U. (2025). Priority Areas For Developing Tour Operator Activities Based On Modern Economic Mechanisms. TLEP–International Journal of Multidiscipline, 2(4), 180-189.
27. Mamadaliyev, U. (2025). The Transformative Impact Of Modern Information And Communication Technologies On The Service Quality Of Tour Operators. TLEP–International Journal of Multidiscipline, 2(4), 159-167.
28. Mamadaliyev, U. (2025). Improving Tour Operator Activities Using Digital Technologies And Innovative Approaches. TLEP–International Journal of Multidiscipline, 2(4), 151-158.
29. Mamadaliyev, U. B. (2024). O‘ZBEKISTONDA TUROPERATORLIK FOALIYATINING RIVOJLANISH HOLATI. University Research Base, 528-531.
30. Ulugbek, M. (2024). MODERN STANDARDS AND TECHNOLOGIES IN MANAGING THE ACTIVITIES OF TOUR OPERATORS. University Research Base, 789-794.

## **The role of morality and etiquette in Arab folk proverbs**

**Nurmatova Mastura Maxmudovna**

**Institute of Social and Political Sciences**

**Senior Lecturer**

**Arabic Language Teacher**

**Phone number:+998933771013**

**e-mail: mastura-2020@mail.ru**

**Abstract:** This article reflects the role of morality and etiquette in Arab folk proverbs and their significance in the Islamic world. The opinions and views of scholars from the Islamic world are presented.

**Keywords:** Morality, oral literature, Hadith, Sahaba, proverb, history, Qur'an, Arab, Ahmad Yasawi, Islam.

## **Араб халқ мақолларида ахлоқ ва одобнинг ўрни**

**Нурматова Мастура Махмудовна**

**ИЖТИМОЙ ВА СИЁСИЙ ФАНЛАР**

**ИНСТИТУТИ**

**КАТТА Ўқитувчи**

**араб тили ўқитувчиси**

**Тел :+998933771013**

**e-mail: mastura-2020@mail. ru**

**Анотация :** Ушбу мақолада араб халқ мақолларида ахлоқ ва одобнинг ўрни ва ислом дунёсидаги роли акс эттирилган . Ислом оламидаги олимларнинг фикр мулоҳазалари баён этилган.

**Калит сўзлар:** Ахлоқ , оғзаки ижод, ҳадис,Саҳоба, мақол, Тарих, Куръон, Араб, Аҳмад Яссавий,Ислом.

Араб халқ оғзаки ижоди асрлар давомида шаклланиб, инсон ҳаёти, жамият муносабатлари ва маънавий қадриятларни ўзида мужассам этган. Айниқса, араб мақолларида ахлоқ ва одоб масаласи алоҳида ўрин тутади. Бу мақоллар нафақат ҳикматли сўз, балки ҳаёт йўриқномаси, тарбия воситаси сифатида ҳам хизмат қилади.

Арабларда “**Ал-ахлоқу зийнатул-инсон**” (“Ахлоқ инсоннинг зийнатидир”) деган машҳур нақл бор. Бу мақол инсонни безайдиган нарса унинг бойлиги ёки ташқи кўриниши эмас, балки гўзал хулқи эканини таъкидлайди. Дарҳақиқат, жамиятда инсоннинг обрў-эътибори, аввало, унинг муомаласи ва одоби билан белгиланади.

Яна бир мақолда: “**Ман ҳасуна хулуқуҳу, касура асдиқоъуху**” (“Хулқи гўзалнинг дўстлари кўп бўлади”) дейилади. Бу ҳикматли сўз ахлоқли инсон жамиятда ҳурмат қозониб, атрофига яхши инсонларни тўплашини англатади. Чунки одамлар доимо самимий, ҳалол ва хушмуомала кишиларга интиладилар.

Одоб масаласи ҳам араб мақолларида кенг ёритилган. “**Ал-адабу фауқа-з-заҳаб**” (“Одоб олтиндан қиммат”) деган мақол одобнинг моддий бойликдан устун эканини кўрсатади. Мол-дунё йўқолиши мумкин, аммо яхши тарбия ва одоб инсон билан умрбод қолади.

Араб диёрлари ва қавмлари Расулulloҳ соллalloҳу алайҳи васаллам сийратлари – ҳаёт йўллари моҳият эътибори билан рисолат тарихидан иборатдир. Расулulloҳ соллalloҳу алайҳи васаллам ушбу рисолатни инсонларга етказдилар ва уларни ана шу рисолат орқали зулматлардан нурга, бандаларга қул бўлишдан Аллоҳга қуллик қилишга олиб чиқдилар. Бинобарин, рисолатнинг комил суратини тўлиқ чизиб кўрсатмоқ учун рисолатдан аввалги ва ундан кейинги ҳолатлар қиёслаб кўрилмоғи лозим. Шунинг учун даставвал арабларнинг қавмлари ва уларнинг Исломдан олдинги ҳолатлари хусусида, Расулulloҳ соллalloҳу алайҳи васаллам рисолат нурини олиб келганларида арабларнинг қай аҳволда эканлиги хусусида сўз юритамиз. Араб диёрлари «Араб» калимасининг луғавий маъноси саҳролар, чўллар, гиёҳ унмайдиган, сувсиз ерлар демакдир. Ўзингиз билганингиздек буюк пайғамбаримиз ҳам ана шу ерларда яшаб ўтдилар. Ислом динини ер юзига тарқатишда бор кучларини сарфладилар. Ҳамда ўзларидан умматларига буюк ҳадиси шарифларни қолдирдилар.

Дарҳақиқат, набавий ҳадисдан беҳожат бўлиш мумкин эмас. Албатта, ислом уммати ҳадисга юқори даражада қаттиқ эътибор қаратган. Тарих бундай эътиборга ҳеч ҳам гувоҳ бўлмаган. Бундай эътиборга сабаб сифатида қуйидагиларни келтириш мумкин:

1)Саҳоба розияллоҳу анҳумлар Пайғамбаримиз соллаллоҳу алайҳи ва салламдан ҳадис эштишга қаттиқ интиланлар. Бунга уларни набавий ҳадиснинг аҳамиятини яхши билганлари, Пайғамбаримизни қаттиқ яхши кўриб у зотга боғланиб қолганлари сабаб бўлган. Умар розияллоҳу анҳу ривоят қилиб айтади: Мени Ансорлардан Умайя ибн Зайд – у Мадинанинг юқори томони – қабиласидан бир қўшним бор эди. Биз навбатлашиб Расулуллоҳ соллаллоҳу алайҳи ва салламнинг ҳузурига борар эдик. Бир куни у тушса, бошқа куни мен тушар эдим. Қачон мен тушсам ўша кунда нозил бўлган ваҳий ва бошқа хабарларни олиб келар эдим. У ҳам тушганда худди шундай қилар эди[1].

Саҳоба розияллоҳу анҳумларни ҳадисга қаттиқ интилиш ва аҳамиятларидан ташқари, бошқа кўплаб омиллар ҳам етарли эди. Бу омиллар уларга ҳадисни тез ёдлаб олиш имкониятни берган. Жумладан,

А) Кучли зеҳнга эга эканликлари. Араблар Исломдан олдин ва исломнинг илк даврларида ҳам ушбу хусусият билан ажраб турар эдилар. Чунки улар ёзишга эмас, балки ёдлаб олишга суянардилар. Ҳаётнинг турли ташвишларидан узок эдилар.

Б) Пайғамбаримиз соллаллоҳу алайҳи ва салламни ҳадисни етказишдаги услублари. У зот қуйидаги услубларга риоя қилардилар: Гапни яхши тушуниб ёдлаб олиш учун шошмасдан сўзлаш;

Гапни қисқа иборалар билан ифодалаш; Бу ҳам тез ёдлаб олишга имкон беради. Оиша розияллоҳу анҳо айтади: Расулуллоҳ соллаллоҳу алайҳи ва саллам дона-дона сўзлар эдилар. Агар сановчи санамоқчи бўлса, санай оларди[2]. Бу гапни шошмасдан ва қисқа тарзда сўзлашни кўрсатади.

Пайғамбаримиз соллаллоҳу алайҳи ва саллам аввалда барча саҳобаларни ҳадисни ёзиб боришдан қайтарганлар. У зот: “Мендан ёзиб олманглар. Ким мендан Қуръондан бошқасини ёзиб олган бўлса, уни ўчирсин”, деб марҳамат қилганлар[3]. Сўнгра Пайғамбаримиз соллаллоҳу алайҳи ва саллам Абдуллоҳ ибн

Амр ибн Ос розияллоҳу анҳу каби баъзи саҳобаларга ҳадисни ёзишга изн берганлар. У киши шундай ривоят қилади: Мен ёдлаб олишим учун Расулуллоҳ соллаллоҳу алайҳи ва салламдан эшитган барча нарсани ёзиб олар эдим. Қурайш мени бундан қайтариб: Сен Расулуллоҳ соллаллоҳу алайҳи ва салламдан эшитган барча нарсани ёзиб олаверасанми? У зот ҳам инсон бўлсалар, ғазаб ва розилик ҳолатида гапирдилар, дейишди. Мен ёзиб юришдан ўзимни тийдим. Сўнг Расулуллоҳ соллаллоҳу алайҳи ва салламга бу ҳақида айтдим. У зот соллаллоҳу алайҳи ва саллам бармоқлари билан оғизларига ишора қилиб: Ёзавер, нафсим Унинг қўлида бўлган зотга қасамки бу ердан фақат ҳақ (сўз) чиқади, дедилар[4]. У кишининг саҳифаларининг исми “Содиқо” бўлган. Бунга сабаб – Аллоҳ билувчи – Пайғамбаримизнинг қуйидаги хавфсирашлари бўлган:

Қуръондан баъзи нарсаларнинг зое бўлиб кетиши. Чунки ёзишни биладиганлар кам бўлган. Шу сабаб Абдуллоҳ ибн Амрни ҳадисни ёзиб бориш билан хослаганлар. Саҳоба розияллоҳу анҳумларнинг суннат сабабли Қуръондан чалғиб қолишлари. Шу сабаб Пайғамбаримиз уларга Қуръон улуғроқ эканини билдириб қўйганлар. Қуръон ёки унинг айрим сўзлари бўлсада бошқа нарсалар билан аралашиб кетиши. Бунга ёзиш воситаларининг озлиги сабаб бўлган. Пайғамбаримиз соллаллоҳу алайҳи ва саллам Абдуллоҳ томонидан бу нарсага хотиржам бўлгач, унга изн бердилар. Сўнг Пайғамбаримиз соллаллоҳу алайҳи ва саллам барча ёзиш истагида бўлганларга рухсат бердилар. Балки гоҳида ёзишга буюрдилар ҳам.

Муоз ибн Анас (розияллоҳу анҳу)дан келтирилган ривоятда Расулуллоҳ (соллаллоҳу алайҳи ва саллам) айтдилар: “Илм ўргатган кишига илмга амал қилган кишининг савоби(дан бирон нарса) камаймаган ҳолда амал қилган кишиникидек етади” (Имом Ибн Можа ривоят қилган)

Мақол деб халқнинг ижтимоий-тарихий, ҳаётий-маиший тажрибаси умумлашган бадий, образли мулоҳазалардан иборат ҳикматли сўзларга айтилади. Мақол ўзбек тилида мақол, тожикларда зарбулмасал, русларда пословица, арабларда (жонли сўзлашувда) нақл, туркларда ата сўзи атамаси билан юритилади. Мақол атамси арабча [قول] – қавлун – гапирмоқ, айтмоқ сўзидан олинган.

Мақолларда сўз қиммати алоҳида ёрқин ифодаланади. Чунки мақоллардаги сўзларни бошқаси билан алмаштириш, бирон сўз қўшиш мумкин эмас. Улар миллий тил таркибида қолиплашган ҳолда намоён бўлади. Бу жанр дунёдаги ҳамма халқлар оғзаки ижодида бор бўлиб, ҳажм, шакл, яратилиши мақсадига кўра муштарак ҳисобланади. Ҳатто номланишида ҳам яқинлик аниқ сезилади. Жумладан, арабларда “қавлун” – гап, сўз маъносини ифодаласа, тожикларнинг “зарбулмасал” атамаларида мисол келтириш, руслар “пословица”сида сўзлар билан фикрни ифодалаш, турклардаги “ота сўзи”да эса аجدодлар фикрини эслаш маъноси етакчи. Маҳмуд Кошғарийнинг “Девону луғотит турк” асарида ҳам “сав” атамаси оталар сўзини эслаш тарзида келтирилган. Аҳмад Яссавий шеърида шундай келади: “Ал ҳаёю минал иймон” – Расул айтди”, яъни Ҳадисдан олинган парча: “Ҳаё иймондан нишонадур”, - дейилади. Аҳмад Югнакий “Ҳибату-л-ҳақойиқ” достонида “Вале кийсанг атлас, унутма бўзинг” мисрасини ёзади. Бу мисра “Бой бўлсанг, чориғингни унутма” ҳикматли сўзига мос келади. Маҳмуд Кошғарий “Девону луғоти-т-турк” тадқиқотида дала сафарларида ёзиб олган 268 мақол матнини келтирган. Бу намуналар қаторида бироз ўзгариш билан яшаётган қуйидагиларни учратамиз: “Отуғ узгуч бирла ўчурмас” – Ўт аланга билан ўчирилмас; “Тоғ тоққа қавушмас, киши кишига қавушар” – “Тоғ тоғ билан учрашмас, одам одам билан учрашар”. Айни пайтда “Ўт теса, ағиз куймас” – ўт деган билан оғиз куймайди; “Тулки ўз инига урса, узуз ўлур” – тулки ўз инига қараб ҳурса, қўтир бўлади кабилар бугунги кунда унутилган. Улар ўрнига “Ҳолва деган билан оғиз чучимас”, “Ватанига тош отган ватангадо бўлади” деган мақоллар қўлланмоқда.

Араб меҳмондорчилиги анъаналарининг илдизи араблар кўчманчи ҳаёт тарзи билан яшаган замонларга бориб тақалади. Саҳрода кетаётган йўловчига бадавийларнинг чодиридан бошқа бошпана топишнинг имкони бўлмаган ва арабларни фақат шундай ўзаро меҳмоннавозликкина, қовжираган ўт-ўлан ва қумлардан иборат чўл-биёбонда ўлиб кетишдан қутқариб қолган. Мезбоннинг меҳмонга илтифотли бўлиши энг олий қадриятлар даражасига кўтарилган ва бу ҳақида Қуръон ва ҳадисларда ҳам алоҳида қайд этиб ўтилган. Меҳмон кутиш фазилати ҳақида мақол ва шеърларда мадҳ қилинган. Меҳмонни уйга қабул қилиш, уч кун давомида едириб-ичириш ва шундан кейингина унинг қаерга йўл олганини сўраш мумкин бўлган. Мезбоннинг иқтисодий аҳволи қандайлигидан

қатъи назар, меҳмонни сахийлик билан қабул қилиш керак бўлган. Араб мақолида меҳмон келган куни камбағаллигини унутиб тур, дейилади. Машҳур имом Ҳатим ал-Асам шундай деган: «Шошқалоқлик – шайтондандир, фақат беш ҳолатда — меҳмонни таомлантириш, маййитни қабрга қўйиш, бўйи етган қизни турмушга узатиш, қарзни қайтариш ва гуноҳлардан тавба қилишда шошилиш бундан мустасно». Араб хонадони учун ушбу сўзлар ҳозирда ҳам ўз долзарблигини сақлаб қолган: туристик йўналишдан адашиб қолган исталган одамга араблар уйининг тўридан жой беради ва сахийлик билан таом келтиради.

Хулоса қилиб айтганда, араб мақоллари ахлоқ ва одобни инсон ҳаётининг энг муҳим фазилатлари сифатида улуғлайди. Улар ёш авлодни тарбиялашда, инсонларни тўғри йўлга бошлашда муҳим аҳамият касб этади. Ахлоқ ва одобга таянган жамиятда эзгулик, ҳамжиҳатлик ва тараққиёт қарор топади. Демак, араб мақолларида илгари сурилган ҳикматлар бугунги кунда ҳам ўз аҳамиятини йўқотмаган.

[1] Ушбу ҳадисни имом Бухорий “Саҳиҳул Бухорий”нинг “Илм китоби” “Илмда навбатлаши боби”да 89-рақам остида ривоят қилган.

[2] Ушбу ҳадисни имом Бухорий “Саҳиҳул Бухорий”нинг “Маноқиб китоби” “Пайғамбар соллаллоху алайҳи ва салламнинг сифатлари боби”да 3568-рақам остида ривоят қилган.

[3] Ушбу ҳадисни имом Муслим “Саҳиҳи Муслим”да “Зухд ва рақоиқлар китоби” “Ҳадисдаги мустаҳкамлик” бобида 3004-рақам остида ривоят қилган.

[4] Имом Абу Довуд “Сунан”да “Илм китоби”да 3646-рақам остида ривоят қилган.

### **Фойдаланилган адабиётлар**

1. Абу Ийсо Муҳаммад Ат-Термизий . “Сунани Термизий”. Мирзо Кенжабек таржимаси .-Т.2013.-528 б.
2. Шайх Муҳаммад Содиқ Муҳаммад Юсуф. Дин насиҳатдир китобидан. Islom.uz.
3. Хайруллаев М.М. Маънавият юлдузлари. Тошкент, 2001.
4. Буёк алломаларимиз. З.Исломов. Тошкент Ислом университети нашриёти -2002.
5. Уватов У. Имом ал-Бухорий. Тошкент, 2002.
6. Ахмаджонов М. Юсупов О. Абдухалимов Б. Олтин Силсила. Саҳиҳул Бухорий. Тошкент .2013й.
7. Зокиржон Исмоил таржимаси. Ҳадис. Тошкент .1991й.

**Theme: Criminal-Legal Essence of Domestic Violence and the Grounds for its  
Criminalization**

Baxramov Fayzullo Jumaboy o'g'li

4th-year student of the Jurisprudence Department,

Faculty of Economics, Tashkent State Transport

University. [fayzullobaxramov@gmail.com](mailto:fayzullobaxramov@gmail.com)

**Abstract:** This article provides a systemic study of the criminal-legal essence of the institution of domestic (household) violence and its transformation within the social life of society. The author substantiates the importance of referring to historical sources when interpreting the conceptual foundations of specific legal phenomena to ensure scientific objectivity. The research offers a comprehensive analysis of the role of Law No. ZRU-829, adopted on April 11, 2023, within the national legal system and the fundamental substance of Article 126<sup>1</sup>, introduced into the Criminal Code of the Republic of Uzbekistan as a result of this legislation.

The central part of the article elucidates the correlation between the concepts of "violence," "harassment," and "stalking," identifying their terminological distinctions and the boundaries between criminal and administrative law. Specifically, the study provides a scientific evaluation of the physical, psychological, economic, and sexual forms of domestic violence, as well as their impact on the victim's psyche and social status. Furthermore, the article analyzes the scientific and theoretical aspects of elevating domestic violence from a "private matter" to a "public problem"—categorizing it as a socially dangerous act that necessitates mandatory state intervention.

**Keywords:** Domestic (household) violence, conceptual, criminalization, implementation, UN (United Nations), unlawful (illegal), violence, harassment, stalking, traumatic bonding, conflict of social roles, aggression, systemic oppression in the family environment, economic and psychological violence, protection order.

**Мавзу: Оилавий (маиший) зўравонликнинг жиноят-ҳуқуқий моҳияти ва унинг криминаллаштирилиш асослари**

**Аннотация:** Мазкур мақолада оилавий (маиший) зўравонлик институтининг жиноят-ҳуқуқий моҳияти ва унинг жамият ижтимоий ҳаётидаги трансформацияси тизимли равишда тадқиқ этилган. Муаллиф муайян ҳуқуқий ҳодисаларнинг концептуал асосларини талқин қилишда тарихий манбаларга мурожаат қилиш орқали илмий объективликка эришиш муҳимлигини асослаб беради. Тадқиқотда 2023 йил 11 апрелда қабул қилинган ЎРҚ-829-сонли Қонуннинг миллий ҳуқуқ тизимидаги ўрни ва унинг натижасида Ўзбекистон Республикаси Жиноят кодексига киритилган 126<sup>1</sup>-модданинг мазмун-моҳияти атрофлича таҳлил қилинган. Мақоланинг марказий қисмида “зўравонлик”, “тазйик” ва “тақиб этиш” тушунчаларининг ўзаро нисбати, уларнинг жиноят ва маъмурий ҳуқуқ соҳаларидаги чегаралари ҳамда терминологик фарқлари очиб берилган. Хусусан, оилавий зўравонликнинг нафақат жисмоний, балки руҳий, иқтисодий ва жинсий шакллари, уларнинг жабрланувчи руҳияти ва ижтимоий ҳолатига таъсири илмий жиҳатдан баҳоланган. Шунингдек, оилавий зўравонликни “шахсий муаммо” тоифасидан “публик муаммо” — яъни давлат аралашуви шарт бўлган ижтимоий хавfli қилмиш даражасига кўтарилиши илмий ва назарий томонлари таҳлил қилинган.

**Калит сўзлар:** Оилавий (маиший) зўравонлик, концептуал, криминализация, имплементация, БМТ, ғайриҳуқуқий, зўравонлик, тазйик, тақиб этиш, травматик боғланиш, ижтимоий роллар тўқнашуви, агрессия, оилавий муҳитдаги тизимли зулм, иқтисодий ва руҳий зўравонлик, ҳимоя ордери.

Муайян ҳуқуқий институтнинг ёки ҳуқуқий ҳодисаларнинг концептуал асосларини талқин қилишда уларнинг тарихий манбаларига мурожаат қилиш илмий объективликни таъминлайди. Жиноят ҳуқуқида Оилага, ёшларга ва ахлоққа қарши жиноятлар институти ҳам бундан мустасно эмас. Шу боис оилавий (маиший) зўравонликни мустақил жиноят таркиби сифатида криминализация (илгари қонуний ёки тартибга солинмаган ҳаракат ёки хатти-ҳаракатлар қонун билан тақиқланиб, уни алоҳида жиноят сифатида белгиланиши<sup>1</sup>) қилиниши ва унинг ҳуқуқий табиатини ўрганиш, жамиятнинг энг муқаддас бўғини ҳисобланмиш оила институтини ҳимоя қилишда муҳим аҳамият касб этади. Мазкур институтнинг тарихий ривожланиш босқичларини тадқиқ этиш орқали шахснинг яқин қариндошлик муносабатларидаги дахлсизлигини баҳолаш ва истиқболдаги ҳимоя механизмларини белгилаш мумкин. Зеро, оилавий муҳитда инсоннинг эрки, шаъни ва жисмоний хавфсизлигини ҳуқуқий жиҳатдан кафолатлаш демократик ҳуқуқий давлатчилик ва инсонпарварлик тамойилларининг энг олий кўриниши десак муболаға бўлмайди. Тарихий тажриба ва замонавий халқаро стандартларнинг уйғунлашуви натижасида, оилавий зўравонликка қарши курашиш институти бугунги кунда инсон ҳуқуқларини ҳимоя қилишнинг глобал тизимида стратегик аҳамиятга эга бўлган марказий йўналишга айланди. Шу сабабли ҳам жиноят ҳуқуқида Оилавий (маиший) зўравонлик тушунчаси ва унинг ижтимоий моҳияти ҳамда келиб чиқиш тарихи, ривожланиш босқичларини тадқиқ этиш устувор вазифалардан биридир.

“Хотин-қизлар ва болалар ҳуқуқлари, эркинликлари ҳамда қонуний манфаатларини ишончли ҳимоя қилиш тизими янада такомиллаштирилиши муносабати билан Ўзбекистон Республикасининг айрим қонун ҳужжатларига

<sup>1</sup> <https://lsd.law/define/criminalization>

Ўзгартиш ва қўшимчалар киритиш тўғрисида”<sup>2</sup> ги 2023 йил 11 апрелдаги 829-сон қонунига мувофиқ, Ўзбекистон Республикаси Жиноят кодексига Оилавий (маиший) зўравонлик жиноятига оид янги норма 126<sup>1</sup>-модда киритилди. Ушбу янги норманинг киритилиши натижасида қатор ўзгартиришлар ва қўшимчалар кирилишига сабаб бўлди. Хусусан, Жиноят кодексининг 17-моддаси иккинчи ва учинчи қисмларига, 66<sup>1</sup>-модданинг биринчи қисмига, 104-105-110-моддаларининг биринчи ҳамда 109-модданинг иккинчи қисми диспозицияларига ўзгартиришлар киритилди.

Оилавий (маиший) зўравонликнинг жиноий қилмиш сифатида эътироф этилиши ва Жиноят кодексига алоҳида норма сифатида киритилиши, энг аввало, халқаро ҳуқуқий стандартларни миллий қонунчиликка имплементация қилиш зарурияти билан белгиланади. Хусусан, ушбу ислохотлар БМТнинг Хотин-қизларни камситишнинг барча шакллариغا барҳам бериш бўйича қўмитасининг Ўзбекистон ҳукуматига йўллаган тавсияларини ижро этиш доирасида амалга оширилди. Мазкур тавсиялар оиладаги зўравонлик учун жиноий жавобгарликни белгилаш, айбдор шахсларга қилмишнинг ижтимоий хавфлилик даражасига муносиб жазо чораларини қўллашни таъминлаш мақсадида Жиноят ва Маъмурий жавобгарлик тўғрисидаги кодекслар ҳамда соҳага оид қонун ҳужжатларига концептуал ўзгартиришлар киритишни тақозо этган эди.

Шу ўринда зўравонлик, тазйиқ ва тақиб этиш ҳамда Оилавий (маиший) зўравонлик тушунчалари ўзи нима, "Оилавий зўравонлик" ва "маиший зўравонлик" тушунчаларининг фарқи, илгари бу "шахсий муаммо" (инсон ҳуқуқларининг хусусий соҳаси) деб қаралар эди, ҳозир эса публик муаммо — яъни давлат аралашishi шарт бўлган ижтимоий хавфли қилмиш эканлиги ва ижтимоий ҳуқуқий моҳияти нималардан иборат эканлигига тўхталиб ўтсак.

<sup>2</sup> Ўзбекистон Республикасининг Қонуни, 11.04.2023 йилдаги ЎРҚ-829-сон - <https://lex.uz/docs/6430272>

Зўравонлик — хотин-қизларга нисбатан жисмоний, руҳий, жинсий ёки иқтисодий таъсир ўтказиш ёки бундай таъсир ўтказиш чораларини қўллаш билан таҳдид қилиш орқали уларнинг ҳаёти, соғлиғи, жинсий дахлсизлиги, шаъни, кадр-қиммати ва қонун билан ҳимоя қилинадиган бошқа ҳуқуқлари ҳамда эркинликларига тажовуз қиладиган ғайриҳуқуқий ҳаракат (ҳаракатсизлик)<sup>3</sup> тушунилади. Демак зўравонликка қисқача бир сўз билан тариф берадиган бўлсак маълум бир шахсга ҳуқуқлар ва эркинликларига қаршилик қилиш ҳамда таъсир ўтказиш ёки таъсир ўтказиш чоралари билан таҳдид солиш орқали ҳаёти, соғлиғи, шаън, кадр-қиммати ва бошқа эркинликларига тажовуз қилувчи ҳаракат ёки ҳаракатсизлик тушунилар экан. Қонунчилигимизда фақатгина хотин-қизларга нисбатан деб тариф берилган бироқ ушбу жиноятнинг жабрланувчиси айнан хотин қизлар эмас балки ёш болалар, эркаклар ёки ўспирин ёшидаги йигитлар ҳам бўлиши мумкин.

Қонунчилигимизда тазйиқ ва тақиб этиш тушунчалари ҳам мавжуд. Бу тушунчаларнинг зўравонлик билан қандай боғлиқлик томонлари бор?

Тазйиқ — содир этилганлиги учун маъмурий ёки жинсий жавобгарлик назарда тутилмаган, хотин-қизларнинг шаъни ва кадр-қимматини камситадиган ҳаракат (ҳаракатсизлик), шилқимлик, таъқиб этиш.

Таъқиб этиш — жабрланувчининг хоҳиш-иродасига қарши, унинг икки ёки ундан ортиқ марта қаршилик кўрсатганлигига ёхуд огоҳлантирганлигига қарамай содир этиладиган, жабрланувчини қидиришда, у билан оғзаки, телекоммуникация тармоқлари воситасида, шу жумладан Интернет жаҳон ахборот тармоғи орқали ёки бошқа усулларни қўллаш йўли билан мулоқотга киришишда, унинг иш, ўқиш

<sup>3</sup> Хотин-қизларни тазйиқ ва зўравонликдан ҳимоя қилиш тўғрисида – Ўзбекистон Республикасининг Қонуни, 02.09.2019 йилдаги ЎРҚ-561-сон. <https://lex.uz/docs/4494709>

ва (ёки) яшаш жойига боришда ифодаланган ҳамда жабрланувчида ўз хавфсизлиги учун хавотирлик кўзгатадиган ҳаракатлар.<sup>4</sup>

Юқорида тазйиқ ва тақиб этиш тушунчаларига эга бўлдик. Бу тушунчаларнинг бир-биридан фарқли жиҳатлари қуйидагича – тазйиқда шахснинг шаъни ва қадр-қимматини камситадиган, унинг иродасини синдиришга қаратилган руҳий, жисмоний ёки иқтисодий таъсир ўтказишда ифодаланиб, мотив-мақсад шахснинг хатти-ҳаракатини зўрлик билан бошқариш ёки маълум бир ишни қилишга (ёки қилмасликка) мажбурлашда намоён бўлади ва кўпинча нофаол ҳаракат билан содир этилади. Тақиб этишда эса шахснинг хоҳиш-иродасига қарши равишда уни изидан кузатиш, алоқага киришишга уриниш ва уни доимий хавотирда сақлашда ифодаланиб, мотив-мақсад жабрланувчининг шахсий ҳаёти дахлсизлигини бузиш ва уни психологик жиҳатдан безовта қилиш билан намоён бўлади ва бу хатти-ҳаракат кўпинча фаол ҳаракатлар билан содир этилади. Хусусиятлари жиҳатдан тазйиқ кўпинча бевосита мулоқотда (юз-ма-юз) содир бўлади. Мисол учун: уйда доимий равишда бақариш, ҳақорат қилиш, иқтисодий жиҳатдан чеклаш ва бошқаларда ифодаланса, тақиб этиш эса зўравон жабрланувчининг яшаш жойида, ишхонасида пайдо бўлиши, телефон ёки ижтимоий тармоқлар орқали тинимсиз хабарлар юбориши мумкин. Зўравонлик бевосита бўлмаса-да, жабрланувчида доимий кўрқув ҳиссини уйғотиш билан амалга оширилади.

Оилавий (маиший) зўравонлик деганда – оила аъзосининг бошқа оила аъзосига нисбатан унинг ҳуқуқларини, эркинликларини, қонуний манфаатларини бузадиган, жисмоний ва (ёки) руҳий азоб уқубатларга олиб келадиган, унинг ҳуқуқларини чеклайдиган, баданга шикаст етказилишига сабаб бўладиган қасддан

<sup>4</sup> Хотин-қизларни тазйиқ ва зўравонликдан ҳимоя қилиш тўғрисида – Ўзбекистон Республикасининг Қонуни, 02.09.2019 йилдаги ЎРҚ-561-сон. <https://lex.uz/docs/4494709>. 3-модда.

содир этиладиган жисмоний, рухий, иқтисодий ёки жинсий характердаги хатти-ҳаракатни содир этилиши тушунилиши лозим.<sup>5</sup>

Демак оила аъзосининг бошқа оила аъзосига нисбатан ҳуқуққа хилоф хатти-ҳаракат содир этиши оилавий (маиший) зўравонлик сифатида баҳоланади. Бунда зўравонлик деганда оилада бирга яшаётган ёки қариндошлик муносабатларида бўлган шахснинг бошқа бир оила аъзосининг инсон сифатидаги ҳуқуқлари, эркинликлари ва қонуний манфаатларини қасддан бузишга қаратилган ҳаракатлари тушунилади. Ушбу ҳаракатлар натижасида жабрланувчининг жисмоний ёки рухий ҳолатига зарар етказилиши, уни қўрқитиш, камситиш, таҳқирлаш, таҳдид қилиш, мажбурлаш орқали босим ўтказиш ёки эркин яшашига тўсқинлик қилиш ҳолатлари юзага келади. Зўравонлик фақатгина тан жароҳати етказиш билан чекланмайди, балки инсон шаъни ва кадр-қимматига тажовуз қилиш, унинг фикр билдириш, меҳнат қилиш, мулкка эгалик қилиш, таълим олиш ёки эркин ҳаракатланиш ҳуқуқларини чеклаш каби ҳолатларни ҳам ўз ичига олади. Бундай хатти-ҳаракатлар жабрланувчининг жисмоний саломатлигигагина эмас, балки унинг рухий ҳолатига, ўз-ўзига ишончига ва жамиятдаги мавқеига ҳам салбий таъсир кўрсатади. Шунингдек, оилавий зўравонлик иқтисодий шаклда ҳам намоён бўлиши мумкин. Масалан, оила аъзосини моддий таъминотдан маҳрум қилиш, унинг даромадидан фойдаланишга рухсат бермаслик, ишлашини тақиқлаш, мол-мулкни тортиб олиш ёки қарзга ботириш орқали уни иқтисодий жиҳатдан қарам ҳолатга солиш шулар жумласидандир. Бу эса шахснинг мустақил қарор қабул қилиш имкониятини чеклайди. Бундан ташқари, жинсий характердаги зўравонлик ҳам оилавий муносабатларда учрайди. У шахснинг розилигисиз жинсий муносабатга мажбурлаш, унинг кадр-қимматини поймол

<sup>5</sup> Баданга қасддан шикаст етказишга оид ишлар бўйича суд амалиёти тўғрисида Ўзбекистон Республикаси Олий суди Пленумининг Қарори, 27.06.2007 йилдаги 6-сон. <https://lex.uz/docs/1592419>

қилиш, шаънига путур етказиш каби хатти-ҳаракатларда ифодаланади. Бу ҳолатлар инсоннинг дахлсизлигига қарши қаратилган оғир ҳуқуқбузарлик ҳисобланади. Хулоса қилиб айтганда, оила аъзосининг бошқа оила аъзосига нисбатан қасддан содир этган жисмоний, руҳий, иқтисодий ёки жинсий характердаги ҳар қандай ҳаракати жабрланувчининг ҳуқуқ ва эркинликларини чеклаб, унга азоб-уқубат етказса, у оилавий зўравонлик сифатида баҳоланади ҳамда қонунчиликка мувофиқ ҳуқуқий жавобгарликка сабаб бўлади.

Нима сабабдан қонунчилигимизда оиладаги зўравонлик эмас балки “Оилавий (маиший) зўравонлик” деган жумла билан белгилаб қўйилган? Бунинг асосий сабаби нима?

Юқоридаги ссаволни турлича таҳлил қилиш мумкин мазмуний тарафдан мулоҳаза қилинса маиший сўзи кундалик турмуш тарзига, уй-рўзғор юмушларига ва инсоннинг яшаши учун зарур бўлган оддий эҳтиёжларга тегишли деган маънони англатади. Бироқ юридик жihatдан унда эмас. Оиладаги зўравонлик билан маиший зўравонликнинг фарқлижihatлари ҳам шунда яъни оилавий зўравонлик — бу қон-қариндошлик ёки никоҳ ришталари билан боғланган инсонлар орасидаги зулмидан ҳиссиётлар ва яқинлик даражаси юқори бўлгани учун жабрланувчининг ёрдам сўраши кийинроқ кечади ва ерда зўравонлик бир марталик жанжал эмас, балки узоқ давом этувчи назорат каби ҳаракатларда намоён бўлади. Маиший зўравонликда эса “рўзғор” ва “уй” тушунчаси билан боғлиқ. Масалан, алоҳида яшайдиган, лекин доимий равишда собиқ турмуш ўртоғига тазйиқ ўтказадиган шахснинг ҳаракати ҳам маиший зўравонликка кириши мумкин.

Оилавий зўравонликда фақат расмий ёки норасмий оила азолари ўртасида(яъни никоҳдаги ёки шаърий никоҳдаги ўртоғи ва бошқалар), маиший зўравонликда эса оила аъзоларидан татурмуш шқари, бирга яшайдиган ёки

рўзғори битта бўлган шахсларни ҳам (яъни бирга яшовчи қариндошлар, собиқ эр-хотинлар ёки ҳатто бир уйда ижарада турувчилар) ўз ичига олади. Шунингдек оилавий зўравонлик кўпинча гендер тенгсизлигига асосланадиган бўлса (яъни эрнинг хотин устидан назорати), маиший зўравонликда ёш ёки ижтимоий мақомга (қайнонанинг келинга ёки катталарнинг болаларга тазйиқи) асосланади. Психологик жихатдан оилавий зўравонликда “Травматик боғланиш” мавжуд бўлиб ушбу ҳолатда жабрланувчи зўравонга ҳиссий боғланиб қолади, маиший зўравонликда "Ижтимоий роллар тўқнашуви" бўлиб бу бир ҳудудда яшаш мажбуриятдан келиб чиқадиган агрессия кўринишида бўлади. Оилавий зўравонликда вақт ўтиши билан зўравонлик шакли ўзгариб боради (масалан, психологик босимдан жисмоний калтаклашга ўтади), маиший зўравонликда маълум бир маиший муаммо ечилмагунча бир хил даражада давом этаверади (масалан, уй-жой талашиш ортидаги доимий заҳархандалик ва шу кабилар). Булар оилавий зўравонлик ва маиший зўравонликнинг бир-биридан асосий фарқли жихатлари ҳисобланади.

Бу иккала ҳаракат ёки ҳаракатсизлик натижасида содир этилалиган ижтимоий ҳавфли қилмишларнинг ўхшаш жихатлари ҳам мавжуд. Булар: латентлик (яширинлик) – ҳар икки қилмиш ҳам жамиятдан сир тугилади. “Уй гапини кўчага чиқарма” деган ижтимоий мазмундаги гаплар иккала ҳолатда ҳам зўравон фойдасига ишлайди. Иккала ҳолатда ҳам асосий мақсад — бошқа шахснинг иродасини синдиришда ифодаланади.

Юқорида амалга оширилган назарий таҳлиллар шуни кўрсатадики, агар қонунчиликда фақатгина “оилавий зўравонлик” тушунчаси билан чекланилса, бу ҳуқуқий тартибга солиш қамровини сезиларли даражада торайтириб қўяди. Чунки, “оилавий” атамаси асосан қон-қариндошлик ва расмий никоҳ ришталарига таянади, ваҳоланки, зўравонлик ҳолатлари фактик равишда бир рўзғор асосида

яшаётган ёки яқин маиший муносабатларда бўлган бошқа шахслар ўртасида ҳам кўп кузатилади. Шу сабабли, миллий қонунчилигимизда “Оилавий (маиший) зўравонлик” бирикмасининг қўлланилиши назарий ва амалий жиҳатдан тўла асосланган. Бу нафақат расмий оила аъзоларини, балки кенг маънодаги маиший муносабатлар иштирокчиларини ҳам ҳуқуқий ҳимоя остига олишга хизмат қилади. Бундай комплекс ёндашув инсон ҳуқуқларини ҳимоя қилишнинг универсал принципларига мос келиб, яширин (латент) зўравонлик ҳолатларига қарши курашиш самарадорлигини оширади.

Эндиликда нима сабабдан бу ижтимоий хавфли ҳаракат(ёки ҳаракатсизлик) илгари "шахсий муаммо" (инсон ҳуқуқларининг хусусий соҳаси) деб қаралар эди, ҳозир эса публик муаммо — яъни давлат аралашishi шарт бўлган ижтимоий хавфли қилмиш эканлигига тўхталиб ўтсак.

Маълумки, 2023 йил 11 апрелдаги ислохотларга қадар миллий қонунчилигимизда “оилавий (маиший) зўравонлик” алоҳида ҳуқуқбузарлик таркиби сифатида эътироф этилмаган эди. Ушбу давргача оилада содир этилган тажовузкор ҳаракатлар соғлиққа етказилган зарарнинг оғирлик даражаси ёки ҳаракатнинг характериға қараб, МЖТКнинг 52-моддаси (Енгил тан жароҳати етказиш), 41-моддаси (Ҳақорат қилиш) ёки 183-моддаси (Майда безорилик) каби умумий нормалар билан малакаланган. Жиноий жавобгарлик масаласи эса фақат маъмурий жазо қўлланилганидан сўнг бир йил давомида қилмиш такроран содир этилган тақдирдагина юзага келган.

Эндиликда савол туғилади нима сабабдан ушбу юқорида санаб ўтилган нормалар билан тартибга солинмасдан МЖТК ҳамда Жиноят кодексига янги 59<sup>2</sup>-126<sup>1</sup>-моддалар қабул қилинди бунинг асосий сабаби нима?

Ушбу янги нормаларнинг қабул қилиниши қуйидаги муҳим заруратлар билан асосланади:

Асосий сабабларидан бири бундай умумий ёндашув оилавий муносабатларнинг ўзига хос мураккаб хусусиятларини қамраб ололмаслиги сабабли, қонунчиликка янги — МЖТКнинг 59<sup>2</sup> ва ЖКнинг 126<sup>1</sup>-моддалари киритилди. Илгари қўлланилган “майда безорилик” ёки “ҳақорат қилиш” нормалари зўравонликнинг фақат ташқи кўринишига баҳо берар эди. Янги нормалар эса зўравонликни “оилавий муҳитдаги тизимли зулм” сифатида алоҳида объект сифатида ажратиб кўрсатди. Аввалги нормалар асосан жисмоний жароҳатга таянган бўлса, янги моддалар иқтисодий ва руҳий зўравонлик учун ҳам тўғридан-тўғри жавобгарликни белгилади. Оилавий зўравонликда жабрланувчи зўравонга моддий ва психологик жиҳатдан боғлиқ бўлади. Янги моддаларнинг жорий этилиши давлатга жабрланувчини ҳимоя қилишда фақат жазолаш эмас, балки ҳимоя ордери ва бошқа профилактик чекловларни қўллаш имконини берди. Умумий нормалар доирасида жавобгарлик кўпинча енгил жарималар билан чекланган. Янги нормалар эса оилавий зўравонликни ижтимоий хавфи юқори бўлган қилмиш сифатида баҳолаб, жазо тизимини қаттиқлаштирди.

Шундай қилиб, оилавий зўравонликнинг алоҳида модда билан криминаллаштирилиши — давлатнинг бу иллатга “шахсий низо” эмас, балки инсон ҳуқуқларини бузувчи ижтимоий хавфли ҳаракат сифатида қарай бошлаганининг ҳуқуқий тасдиғи бўлди.

Хулоса сифатида айтиш мумкинки, оилавий зўравонликнинг криминализация қилиниши Ўзбекистон жиноят ҳуқуқи назариясида муҳим бурилиш ясади. Илгари ушбу қилмиш шахсий муносабатларнинг бир қисми сифатида “ёпиқ” муаммо деб қаралиб, фақат оғир оқибатлар келиб чиққандагина давлатнинг эътиборига тушган. Янги ҳуқуқий талқинга кўра, зўравонлик эндиликда инсон ҳуқуқларини бузувчи, оиланинг муқаддаслиги ва шахс дахлсизлигига тажовуз қилувчи публик хавфли ҳодиса сифатида эътироф этилди.

Бу давлатнинг оиладаги тазйиққа нисбатан мурасасиз позициясини ҳуқуқий жиҳатдан мустаҳкамлади. “Оилавий” ва “маиший” зўравонлик тушунчаларининг биргаликда қўлланилиши ҳуқуқий ҳимоя объектини сезиларли даражада кенгайтди. Тадқиқот шуни кўрсатадики, фақат никоҳ ришталари билан чекланиб қолмай, балки фактик рўзғор бирлиги ёки яқин маиший муносабатларни ҳам қамраб олиш — яширин (латент) зўравонлик ҳолатларини аниқлаш ва уларга барҳам беришнинг ягона самарали йўлидир. Бу билан қонун чиқарувчи “жабрланувчи” тушунчасини фақат расмий ҳужжатларга эмас, балки амалдаги ижтимоий воқеликка мослаштирди. Жиноят кодексига 126<sup>1</sup>-модданинг киритилиши ва бошқа моддалар (104, 105, 110-моддалар) билан диспозитив боғлиқлигининг таъминланиши — жазо муқаррарлиги тамойилини кучайтирди. Эндиликда зўравонликнинг тўртта шакли (жисмоний, руҳий, иқтисодий ва жинсий) учун алоҳида жавобгарликнинг белгиланиши, ҳуқуқни қўллаш амалиётида илгари эътибордан четда қолган руҳий босим ва иқтисодий қарамлик каби латент қилмишларни ҳам ҳуқуқий баҳолаш имконини беради. Ислоҳотларнинг БМТнинг CEDAW қўмитаси тавсиялари асосида амалга оширилгани миллий қонунчиликни халқаро инсон ҳуқуқлари тизими билан интеграция қилди. Оилавий зўравонлик учун алоҳида жавобгарликнинг мавжудлиги — потенциал ҳуқуқбузарлар учун кучли психологик тўсиқ ва жабрланувчилар учун давлат ҳимояси кафолати бўлиб хизмат қилади. Юқоридаги назарий таҳлилдан келиб чиқиб, қуйидагича қўшимча ва таклифларни киритиш мумкин. Оилавий (маиший) зўравонлик жиноятини содир этган ва жазо тайинланган шахсларга нисбатан фақат жазолаш билан чекланмай, зўравон шахсларнинг хулқ-атворини ўзгартиришга қаратилган мажбурий психологик коррекция дастурларини жорий этиш.

### Фойдаланилган адабиётлар

1. Ўзбекистон Республикасининг Қонуни, 11.04.2023 йилдаги ЎРҚ-829-сон - <https://lex.uz/docs/6430272>
2. Хотин-қизларни тазйиқ ва зўравонликдан ҳимоя қилиш тўғрисида – Ўзбекистон Республикасининг Қонуни, 02.09.2019 йилдаги ЎРҚ-561-сон. <https://lex.uz/docs/4494709>
3. Баданга қасддан шикаст етказишга оид ишлар бўйича суд амалиёти тўғрисида Ўзбекистон Республикаси Олий суди Пленумининг Қарори, 27.06.2007 йилдаги 6-сон. <https://lex.uz/docs/1592419>
4. “Ички ишлар органларининг оиладаги зўравонлик билан боғлиқ ҳуқуқбузарликлар профилактикасини такомиллаштириш” диссертация А.Ш.Муродов
5. Ўзбекистон Республикаси жиноят кодекси – 22.09.1994 йил
6. Ўзбекистон Республикасининг Маъмурий жавобгарлик тўғрисидаги кодекси – 01.04.1995 йил.
7. “Оилавий зўравонлик” – мутахасислар учун қўлланма. А.Волошчук, М. Инакова. [https://civicportal.org/files/publikacje/files/133\\_](https://civicportal.org/files/publikacje/files/133_)
8. Oilaviy (maishiy) zo‘ravonlik jinoyatlarini sudlarda ko‘rish amaliyoti. Тошкент 2024 йил. [https://www.undp.org/uz/uzbekistan/publications/oilaviy-maishiy-zoravonlik-jinoyatlarini-sudlarda-korish-amaliyoti?utm\\_source=chatgpt.com](https://www.undp.org/uz/uzbekistan/publications/oilaviy-maishiy-zoravonlik-jinoyatlarini-sudlarda-korish-amaliyoti?utm_source=chatgpt.com)

## **PROSPECTS FOR THE FORMATION AND DEVELOPMENT OF ARTIFICIAL INTELLIGENCE POLICY IN UZBEKISTAN**

**Author: Amirova Shohista**

### **ABSTRACT**

Artificial intelligence (AI) is becoming a key driver of global technological and socio-economic transformation. This article examines the prospects for the formation and development of artificial intelligence policy in Uzbekistan. The study analyzes national digital transformation strategies, institutional frameworks, and international experience in AI governance. Particular attention is given to the role of education, infrastructure, and innovation ecosystems in shaping sustainable AI policy. The research identifies key challenges, including limited research capacity, insufficient funding, and the need for regulatory improvements. The findings suggest that strengthening digital infrastructure, investing in human capital, and expanding international cooperation are essential for the effective implementation of AI policy in Uzbekistan.

### **KEYWORDS**

Artificial intelligence, digital transformation, innovation policy, Uzbekistan, digital economy, technology governance, public administration

### **INTRODUCTION**

Artificial intelligence has rapidly evolved into a strategic technology influencing economic development, governance systems, and social processes worldwide. According to international studies, AI technologies are expected to contribute trillions of dollars to the global economy in the coming decades. Governments are increasingly adopting national AI strategies to ensure technological competitiveness and sustainable development.

Uzbekistan has initiated a series of reforms aimed at digital transformation and the modernization of public administration. National programs related to digital economy development, e-government systems, and innovation infrastructure indicate growing recognition of the importance of artificial intelligence.

However, the formation of a comprehensive AI policy requires systematic analysis of institutional capacity, technological readiness, and human capital development.

Recent academic literature emphasizes that artificial intelligence policy must integrate technological innovation, ethical standards, and regulatory frameworks. Russell and Norvig (2021) highlight the transformative potential of AI across multiple industries. Brynjolfsson and McAfee (2018) argue that digital technologies are reshaping labor markets and productivity patterns globally.

OECD reports (2022) underline the importance of national strategies, public-private partnerships, and education reforms in successful AI implementation. The World Bank (2023) stresses the role of digital infrastructure and data governance in developing economies.

These studies provide a theoretical foundation for analyzing AI policy development in Uzbekistan.

This research is based on qualitative and analytical methods, including:

- analysis of national policy documents and strategic programs
- comparative analysis of international AI strategies
- review of statistical and analytical reports from international organizations
- synthesis of academic literature related to digital transformation and innovation policy

The methodological approach allows identifying key trends, opportunities, and challenges in the development of artificial intelligence policy.

Uzbekistan has made progress in digital governance and innovation policy. The establishment of IT Park Uzbekistan and the expansion of digital services have contributed to the development of the national IT ecosystem. Government initiatives aimed at increasing internet accessibility and digital literacy also create favorable conditions for AI development.

One of the most critical factors in AI policy development is the availability of qualified specialists. Universities in Uzbekistan have begun introducing programs in data science, artificial intelligence, and software engineering. However, the number of specialists remains insufficient compared to growing market demand.

Digital infrastructure plays a central role in enabling AI technologies. Improvements in broadband connectivity, cloud computing, and data storage systems are necessary for large-scale AI applications. Startups and innovation hubs are gradually emerging, especially in fintech and digital services.

The analysis shows that Uzbekistan has significant potential for AI development but faces structural challenges. Limited research funding, insufficient collaboration between academia and industry, and regulatory gaps remain key barriers.

International experience demonstrates that long-term investment in research and education is essential for sustainable AI development. Countries that have successfully implemented AI policies have established strong institutional frameworks and promoted interdisciplinary collaboration.

For Uzbekistan, adapting international best practices while considering national socio-economic conditions is crucial.

## CONCLUSION

Artificial intelligence can become a powerful driver of economic growth and modernization in Uzbekistan. The country has already established the initial foundations for digital transformation, but further progress requires a comprehensive AI policy integrating education, infrastructure, research, and regulation.

Strengthening human capital, improving digital infrastructure, and expanding international cooperation will be essential for ensuring sustainable and inclusive technological development.

## REFERENCES

Russell, S., Norvig, P. Artificial Intelligence: A Modern Approach. Pearson, 2021.

Brynjolfsson, E., McAfee, A. The Second Machine Age. Norton, 2018.

OECD. Artificial Intelligence Policy Observatory Report, 2022.

World Bank. Digital Development Overview, 2023.

European Commission. Artificial Intelligence Strategy, 2022.

IT Park Uzbekistan Annual Report, 2023.

Ministry of Digital Technologies of the Republic of Uzbekistan. Digital Transformation Reports, 2023

## **THE DIPLOMATIC AND CULTURAL SIGNIFICANCE OF UNESCO'S 43RD SESSION FOR UZBEKISTAN**

*Mavlanova Dilrabo Farxotjon qizi*

*2nd-year student of the Political Science program University  
of Journalism and Mass Communications of Uzbekistan,*

*Tel.: (93) 962-83-06*

*E-mail: [mavlonovadilrabo2705@gmail.com](mailto:mavlonovadilrabo2705@gmail.com)*

**Annotation.** *This article analyzes the diplomatic, cultural, and symbolic significance of the 43rd YUNESKO Session held in 2025 in Samarkand for the Republic of Uzbekistan. It examines President Shavkat Mirziyoyev's address, the participation of international delegations, the expansion of cultural diplomacy, and the strengthening of national heritage policies. The study evaluates the session's impact on Uzbekistan's global standing and its long-term cultural strategy.*

**Keywords:** *YUNESKO, Samarkand, cultural heritage, diplomacy, Uzbekistan, international cooperation.*

### **YUNESKONING 43-SESSIYASINING O'ZBEKISTON UCHUN DIPLOMATIK VA MADANIY AHAMIYATI**

*Mavlonova Dilrabo Farxotjon qizi*

*O'zbekiston Jurnalistika va ommaviy kommunikatsiyalar  
universiteti "Siyosatshunoslik" yo'nalishi 2-bosqich talabasi,*

*Tel.: (93) 962-83-06*

*Elektron pochta: [mavlonovadilrabo2705@gmail.com](mailto:mavlonovadilrabo2705@gmail.com)*

**Annotatsiya.** *Ushbu maqolada 2025-yilda Samarqand shahrida o'tkazilgan YUNESKOning 43-sessiyasi O'zbekiston uchun diplomatik, madaniy va ma'naviy jihatdan qanday strategik ahamiyat kasb etgani tahlil qilinadi. Prezident Shavkat Mirziyoyevning ushbu sessiyadagi nutqi, xalqaro delegatsiyalarning ishtiroki, madaniy diplomatiya imkoniyatlarining kengayishi va milliy meros siyosatining kuchayishi asosiy yo'nalish sifatida yoritiladi. Sessiyaning O'zbekistonning global maydondagi nufuziga ko'rsatgan ta'siri ilmiy nuqtai nazardan baholanadi.*

**Kalit so'zlar:** *YUNESKO, Samarqand, madaniy meros, diplomatiya, O'zbekiston, xalqaro hamkorlik.*

## **ДИПЛОМАТИЧЕСКОЕ И КУЛЬТУРНОЕ ЗНАЧЕНИЕ 43-Й СЕССИИ ЮНЕСКО ДЛЯ УЗБЕКИСТАНА**

*Мавланова Дилрабо Фархотжон кизи*

*студентка 2 курса направления «Политология»*

*Университета журналистики и массовых коммуникаций Узбекистана,*

*Тел.: (93) 962-83-06*

*Электронная почта: [mavlonovadilrabo2705@gmail.com](mailto:mavlonovadilrabo2705@gmail.com)*

***Аннотация.** В статье анализируется дипломатическое, культурное и символическое значение 43-й сессии ЮНЕСКО, состоявшейся в 2025 году в Самарканде, для Республики Узбекистан. Особое внимание уделяется выступлению Президента Шавката Мирзиёева, участию международных делегаций, расширению возможностей культурной дипломатии и укреплению государственной политики в сфере наследия. Оценивается влияние сессии на международный имидж Узбекистана и долгосрочную стратегию страны в сфере культурного наследия.*

***Ключевые слова:** ЮНЕСКО, Самарканд, культурное наследие, дипломатия, Узбекистан, международное сотрудничество*

Bugungi globallashuv davrida xalqaro munosabatlar faqat siyosiy va iqtisodiy maydon bilangina cheklanib qolmay, madaniy, gumanitar va intellektual resurslar asosida ham shakllantirilmoqda. Shu jihatdan olib qaraganda, YUNESKO tashkiloti xalqaro hamkorlikni mustahkamlash, madaniy merosni asrab-avaylash hamda ta`lim sohasida ilgari surilgan ilg`or tashabbuslarni qo`llab-quvvatlashda muhim tashkilotlardan biri hisoblanadi. 2025-yil 30-oktabrdan 13-noyabrga qadar Samarqand shahrida o`tkazilgan YUNESKO Bosh Konferensiyasining 43-sessiyasi O`zbekiston tarixida ham, tashkilot faoliyati tarixida ham alohida sahifa bo`lib kirgan yirik diplomatik voqea bo`ldi. Buning asosiy sababi tashkilotning navbatdagi sessiyasi so`nggi qariyb 40 yil ichida ilk bor Tashkilot qarorgohidan tashqarida o`tkazilganligi bo`ldi. Mazkur eng yirik xalqaro forumning Samarqandda o`tkazilgani O`zbekistonga nisbatan xalqaro ishonchning ortganidan dalolat beradi. Mazkur konferensiyaning muvaffaqiyatli yakunlanishi mamlakatning global madaniy diplomatiyadagi mavqeini

keskin mustahkamlab, uning xalqaro maydondagi tashabbuskorligini yangi bosqichga ko'tardi<sup>1</sup>.

Sessiya doirasida O'zbekiston Prezidenti Shavkat Mirziyoyevning nutqi, 190 davlatdan kelgan delegatsiyalar ishtiroki, 150 dan ortiq tadbirlarning o'tkazilgani<sup>2</sup>, shuningdek, tarixda ilk bor "O'zbekiston xalqi va hukumatiga minnatdorlik ifodasi" nomli maxsus rasmiy hujjatning qabul qilinishi mamlakatning diplomatik nufuzi va madaniy salohiyatini global miqyosda tan olinishini ifodaladi<sup>3</sup>. Prezident Shavkat Mirziyoyev o'z nutqida bu ishonchni "Yangi O'zbekistonda amalga oshirilayotgan keng ko'lamlı, jadal islohotlarga berilgan yuksak baho" sifatida qayd etdi<sup>4</sup>. Bu jarayon nafaqat O'zbekiston tashqi siyosatining muvaffaqiyatidir, balki mamlakatning qadimiy merosi, zamonaviy rivojlanish strategiyasi va xalqaro hamkorlikka sodiqligining ham yorqin isbotidir.

Sessiya ochilishida O'zbekiston Prezidenti Shavkat Mirziyoyevning nutqi jarayonning mazmun-mohiyatini belgilab berdi. Prezident xalqaro hamjamiyatni umumiy merosni asrash va insoniyatning madaniy rishtalarini mustahkamlashga da'vat etib, O'zbekistonning ushbu yo'nalishdagi prinsipial pozitsiyasini ta'kidladi. Davlat rahbari madaniy meros nafaqat tarixiy xotira, balki barqaror rivojlanishning muhim omili ekanini qayd etib, YUNESKO doirasida O'zbekiston tomonidan ilgari surilgan yangi tashabbuslarni taqdim etdi. O'zbekistonning boy madaniy merosini dunyoga tanitish sessiyaning eng muhim yo'nalishlaridan biri bo'ldi. Ishtirokchilar uchun Samarqandning tarixiy markazi, Siyob bozori, Afrosiyob manzili, shuningdek,

---

<sup>1</sup> UNESCO. General Conference, 43rd session. – Samarkand, 2025. (Rasmiy hujjatlar va rezolyutsiyalar).

<sup>2</sup> Samarqandda UNESCO Bosh konferensiyasining 43-sessiyasi ochildi // Gazeta.uz. – 2025-yil 30-oktabr.

URL: <https://www.gazeta.uz/oz/2025/10/30/unesco-open/>

<sup>3</sup> UNESCO Bosh konferensiyasining 43-sessiyasi yakunlari to'g'risida. O'zbekiston xalqi va hukumatiga minnatdorlik ifodasi // O'zbekiston Respublikasi Tashqi ishlar vazirligi. – 2025-yil 13-noyabr.

URL: <https://gov.uz/oz/mfa/news/view/101949>

<sup>4</sup> O'zbekiston Respublikasi Prezidenti Sh.M. Mirziyoyevning UNESCO Bosh konferensiyasining 43-sessiyasi ochilish marosimidagi nutqi. – Samarqand, 2025-yil 30-oktabr.

URL: <https://president.uz/uz/lists/view/8610>

“Registon” maydonida tashkil etilgan madaniy dasturlar namoyish etildi. Bu tadbirlar mamlakatning turizm salohiyatini oshirish, milliy qadriyatlarni targ‘ib qilish hamda madaniy brend sifatida O‘zbekiston qiyofasini mustahkamlashga xizmat qildi. Samarqandning YUNESKO ro‘yxatidagi maqomi, tarixiy markazining betakrorligi ham sessiyaning ramziy, ham amaliy jihatdan muvaffaqiyatiga xizmat qildi<sup>5</sup>. 2800 dan ortiq delegatning ushbu qadimiy shahardan olgan taassurotlari O‘zbekistonning turizm, madaniyat diplomatiyasi va global imijiga katta hissa qo‘shdi. 43-sessiya raisi Xondker Talhaning O‘zbekiston rahbariyatiga bildirgan minnatdorligi, boshqa delegatlarning “Bu faqat diplomatik emas, ma’naviy tajriba bo‘ldi” degan baho esa O‘zbekistonning madaniy kuch diplomatiyasini (soft power) yanada yuksaltirdi.

Prezident tomonidan ilgari surilgan tashabbuslar mazmunan keng qamrovli bo‘lib, YUNESKOning asosiy yo‘nalishlari — ta’lim, madaniyat, ilm-fan, axborot xavfsizligi va gender tengligi kabilar bilan to‘liq uyg‘unlashgan. Avvalo, inklyuziv ta’lim, sun’iy intellekt va raqamli taraqqiyot doirasida amalga oshirilishi zarur bo‘lgan ishlar bo‘yicha qqator takliflar kiritildi. Xususan, alohida ehtiyojli bolalar uchun global inklyuziv ta’lim platformalarini yaratish, “Sun’iy intellekt — maktab” namunaviy loyihasini ishlab chiqish hamda sun’iy intellekt etikasi bo‘yicha xalqaro ekspertlar anjumani tashkil etish shular jumlasidandir. Bu tashabbuslar YUNESKOning XXI asr chaqiriqlariga — texnologiyalar etikasi, raqamli tengsizlik, ta’limning kelajagi kabi masalalarga to‘g‘ridan-to‘g‘ri mos keladi. O‘zbekiston bu yo‘nalishlarda global muhokamalarga faol ulanishi bilan o‘zining innovatsion davlat sifatidagi qiyofasini mustahkamladi.

Bundan tashqari, jahon nomoddiy madaniy merosini saqlab qolish maqsadida YUNESKO “Jahon xotirasi” dasturini rivojlantirish, 19-noyabrni “Hujjatli meros xalqaro kuni” sifatida e’lon qilish, Raqamli meros bo‘yicha xalqaro institut tashkil etish takliflari ham ilgari surildi. Bu takliflar O‘zbekistonning so‘nggi yillardagi yutuqlari sifatida 14 ta nomoddiy meros elementi YUNESKO ro‘yxatiga kiritilganini, Xiva, Buxoro, Shahrisabz va Samarqandning xalqaro maqomini samarali mustahkamlaydi.

---

<sup>5</sup> UNESCO. World Heritage List & Intangible Cultural Heritage of Uzbekistan. – 2025.

Uchinchi masala doirasida esa YUNESKO Ayollar yetakchiligi akademiyasini tashkil etish, Samarqandda ayollarning Ta'lim, madaniyat va fan sohasidagi global forumini o'tkazish kabi takliflar ishlab chiqilgan. Bu tashabbuslar O'zbekistonning gender siyosatini xalqaro maydonga olib chiqdi hamda mamlakatni ayollar huquqlarini ilgari suruvchi mintaqaviy markaz sifatida ko'rsatdi.

Qolaversa, bugungi davrning dolzarb ahamiyatli masalalaridan biri bo'lgan iqlim inqiroziga qarshi kurashning samarali kechishi uchun "YUNESKO ekologik poytaxti" global tashabbusi, iqlim o'zgarishi sharoitida madaniy merosni himoya qilish" to'g'risidagi rezolyutsiyasi va shu mavzu doirasida Xivada xalqaro simpozium o'tkazish takliflari kiritildi. Bu tashabbuslar Orol dengizining tiklanishi, mintaqaviy ekologik diplomatiya va O'zbekistonning global ekologik siyosatdagi rolini kuchaytiradi.

Shu bilan birga, zamonaviy davrning virtual makonidagi axborot xurujlari, jamoatchilik fikrini chalg'itish va diskriminatsiyaga qarshi choralar sifatida media savodxonlik strategiyasini ishlab chiqish, bolalar madaniy kontenti festivali, islomofobiyaga qarshi hamkorlik: Imom Buxoriy, Moturidiy, Termiziy, Naqshband kabi markazlar bilan ilmiy loyihalar. Bu tashabbuslar O'zbekistonni xalqaro intellektual va diniy-ma'rifiy markaz sifatida mustahkamlaydi.

YUNESKO sessiyasi O'zbekiston uchun nafaqat diplomatik muvaffaqiyat, balki milliy o'zlikni anglash va ma'naviy tiklanish jarayonining muhim tarkibiy qismi bo'ldi. Mamlakatning tarixiy-madaniy merosi jahon hamjamiyati tomonidan yana bir bor e'tirof etildi. O'zbekiston ilgari surgan tashabbuslarning qo'llab-quvvatlanishi, yangi yodgorliklarni Butunjahon merosi ro'yxatiga kiritish bo'yicha muzokaralarning faollashuvi, ilmiy ekspeditsiyalar va restavratsiya dasturlarining kengayishi sessiyaning amaliy natijalaridan biridir.

Xulosa qilib aytganda, YUNESKOning 43-sessiyasi O'zbekistonning xalqaro hamjamiyatdagi madaniy-diplomatik o'rnini mustahkamladi, milliy meros siyosatining global darajadagi dolzarbligini namoyon qildi va mamlakatning tarixiy merosni asrash borasidagi uzoq muddatli strategiyasida yangi bosqichni boshlab berdi. Sessiya O'zbekistonni madaniy integratsiya, ilmiy hamkorlik va diplomatik aloqalarning mintaqaviy markaziga aylantirish jarayonini sezilarli darajada jadallashtirdi.

### FOYDALANILGAN ADABIYOTLAR

<sup>1</sup> UNESCO. General Conference, 43rd session. – Samarkand, 2025. (Rasmiy hujjatlar va rezolyutsiyalar).

<sup>2</sup> Samarqandda UNESCO Bosh konferensiyasining 43-sessiyasi ochildi // Gazeta.uz. – 2025-yil 30-oktabr.

URL: <https://www.gazeta.uz/oz/2025/10/30/unesco-open/>

<sup>3</sup> UNESCO Bosh konferensiyasining 43-sessiyasi yakunlari to‘g‘risida. O‘zbekiston xalqi va hukumatiga minnatdorlik ifodasi // O‘zbekiston Respublikasi Tashqi ishlar vazirligi. – 2025-yil 13-noyabr.

URL: <https://gov.uz/oz/mfa/news/view/101949>

<sup>4</sup> O‘zbekiston Respublikasi Prezidenti Sh.M. Mirziyoyevning UNESCO Bosh konferensiyasining 43-sessiyasi ochilish marosimidagi nutqi. – Samarqand, 2025-yil 30-oktabr.

URL: <https://president.uz/uz/lists/view/8610>

<sup>5</sup> UNESCO. World Heritage List & Intangible Cultural Heritage of Uzbekistan. – 2025.

## **THE MORAL AND SPIRITUAL CHOICE BETWEEN FAITH AND CONSCIENCE IN THE VIEWS OF OZOD SHARAFIDDINOV**

*Mavlanova Dilrabo Farxotjon qizi*

*2nd-year student of the Political Science program University  
of Journalism and Mass Communications of Uzbekistan,*

*Tel.: (93) 962-83-06*

*E-mail: [mavlonovadilrabo2705@gmail.com](mailto:mavlonovadilrabo2705@gmail.com)*

**Annotation.** *This article is based on Ozod Sharafiddinov's work "Why I Changed My Belief?" and analyzes the issues of personal belief, moral courage, and conscious responsibility of the individual. The study examines the formation of the author's worldview under the influence of Soviet ideology, his inner experiences, and his courage in the pursuit of truth. Furthermore, the research highlights the complex relationships between loyalty and conscience, ideology and critical reflection, moral courage and social responsibility, viewed through the historical and reflective perspective of Sharafiddinov's creative legacy. The article enables readers to gain a profound understanding of the problems of belief and courage not only from a literary, but also from a scholarly point of view.*

**Keywords:** *Ozod Sharafiddinov, belief, moral courage, reflective responsibility, ideology, conscience, Soviet era.*

### **E'TIQOD VA VIJDON O'RTASIDAGI MA'NAVIY TANLOV: OZOD SHARAFIDDINOV QARASHLARI**

*Mavlonova Dilrabo Farxotjon qizi*

*O'zbekiston Jurnalistika va ommaviy kommunikatsiyalar  
universiteti "Siyosatshunoslik" yo'nalishi 2-bosqich talabasi,*

*Tel.: (93) 962-83-06*

*Elektron pochta: [mavlonovadilrabo2705@gmail.com](mailto:mavlonovadilrabo2705@gmail.com)*

**Annotatsiya.** *Ushbu maqola Ozod Sharafiddinovning "E'tiqodimni nega o'zgartirdim?" asari asosida yozilgan bo'lib, unda shaxsiy e'tiqod, ma'naviy jasorat va shaxsning ongli mas'uliyati muammolari tahlil qilinadi. Maqolada muallif dunyoqarashining sovet davri mafkurasi ta'sirida shakllanish jarayoni, uning ichki kechinmalari va haqiqatga erishish yo'lidagi jasorati ko'rsatib beriladi. Tadqiqotda, shuningdek, Sharafiddinov ijodining tarixiy va chuqur tafakkur nuqtai nazari bilan*

*birga sadoqat va vijdon, mafkura va tafakku, ma'naviy jasorat va ijtimoiy mas'uliyat o'rtasidagi murakkab munosabatlar yoritiladi. Maqola o'quvchiga nafaqat badiiy, balki ilmiy nuqtai nazardan ham e'tiqod va jasorat masalalarini chuqur anglash imkonini beradi.*

***Kalit so'zlar:** Ozod Sharafiddinov, e'tiqod, ma'naviy jasorat, tafakkuriy mas'uliyat, mafkura, vijdon, sovet davri*

## **МОРАЛЬНО-ДУХОВНЫЙ ВЫБОР МЕЖДУ ВЕРОЙ И СОВЕСТЬЮ В ВОЗЗРЕНИЯХ ОЗОДА ШАРАФИДДИНОВА**

*Мавланова Дилрабо Фархотжон кизи  
студентка 2 курса направления «Политология»  
Университета журналистики и массовых коммуникаций Узбекистана,  
Тел.: (93) 962-83-06  
Электронная почта: [mavlonovadilrabo2705@gmail.com](mailto:mavlonovadilrabo2705@gmail.com)*

***Аннотация.** Данная статья основана на произведении Озода Шарафиддинова «Почему я изменил свои убеждения?» и посвящена анализу проблем личной веры, моральной смелости и осознанной ответственности личности. В работе рассматривается процесс формирования мировоззрения автора под воздействием идеологии советского периода, его внутренние переживания и мужество на пути поиска истины. Кроме того, в исследовании освещаются сложные взаимосвязи между преданностью и совестью, идеологией и критическим мышлением, моральной смелостью и социальной ответственностью в историко-интеллектуальном ракурсе творческого наследия Шарафиддинова. Статья позволяет читателю глубоко осмыслить проблемы веры и мужества не только с художественной, но и с научной точки зрения*

***Ключевые слова:** Ozod Sharafiddinov, vera, moral'naya smelost', refleksivnaya otvetstvennost', ideologiya, sovest', sovet'skaya epokha..*

### **KIRISH**

*Ba'zan inson hayotida shunday vaziyatlar yuz beradi-ki, ularni tushunish va ularga javob berish juda murakkab bo'ladi. Bu jarayonlar uning dunyoqarashi, e'tiqodi*

va shaxsiy qadriyatlarini tubdan o`zgartirib yuborishi mumkin. Ayniqsa, totalitar siyosiy tuzum sharoitida shakllangan ong uchun haqiqatni anglash va unga sodiq qolish nihoyatda og`ir kechadi. Ana shunday tarixiy sharoitda yashab ijod qilgan Ozod Sharafiddinovning “E`tiqodimni nega o`zgartirdim?” maqolasi aynan shu murakkab ichki kurash jarayonlarini yoritib bergani bilan alohida ahamiyatga ega. U yerda e`tiqod va haqiqat o`rtasidagi ziddiyat, shaxsiy tajriba, va vijdoniy tanlovlar yorqin ifodalanadi. Sharafiddinov o`z hayotini oqlashga urinmaydi, balki kechmishi bilan ochiq yuzlashadi va o`quvchini ham fikrlashga undaydi.

Ozod Sharafiddinov XX asr sovet davrida o`sgan, komsomol va pioner tizimi orqali shakllangan ongning mahsulidir. Sharafiddinovning hayotiy va ijodiy tajribasi shuni ko`rsatadiki, sovet mafkurasi shunchaki siyosiy tizim emas, balki shaxs ongini shakllantiruvchi vosita bo`lgan. Uning dastlabki e`tiqodi ham tizim tomonidan shunday shakllantirilgan. Muallif dastlab ushbu mafkuraga chin dildan ishonganini ochiq e`tirof etadi. U adolat, tenglik va insonparvarlik kabi yuksak g`oyalarning chinakam amalga oshishiga ishonib, ularni mukammal tarzda tasavvur qilgan; pionerlik va komsomol faoliyati orqali dunyoqarashi rivojlangan. Biroq vaqt o`tishi bilan bu tizimning yuzaki go`zalligining ortida zulm, ikkiyuzlamachilik va shaxsiy erkinlikning poymol qilinishi yashirilganini sezadi. Shu nuqtadan e`tiboran, Sharafiddinovning ichki dunyosi sadoqat va shubha, e`tiqod va haqiqat o`rtasida murakkab bahsga kiradi.

### **E`tiqod va vijdon o`rtasidagi ziddiyat**

Maqolada muallif e`tiqodini o`zgartirish qarorini shaxsiy zaiflik yoki qo`rqoqlik sifatida emas, balki ma`naviy zarurat sifatida talqin qiladi. U sovet mafkurasining inson ongiga qanday singdirilganini, qanday qilib odamlar “haqiqat” deb qabul qilgan narsalarga shubhasiz ishonganini batafsil yoritadi. Pionerlik, komsomollik va Stalin shaxsiga sig`inish orqali shakllangan ong insonni aldash uchun majburlash shart emasligini ko`rsatadi; ongni boshidan bir yo`nalishga solish ham yetarli.

E`tiqod va vijdon o`rtasidagi ziddiyat Sharafiddinov ijodida markaziy o`rin tutadi. O`sha davr sovet mafkurasi shunchaki siyosiy yo`nalish emas, balki shaxsning ongini shakllantiruvchi kuch edi. Muallif dastlab mafkuraga sadoqatini saqlashni xohladi, lekin vaqt o`tishi bilan u insoniy haqiqat va vijdon bilan yuzlashdi. Shu nuqtai nazardan qaraganda, sadoqatning haqiqiy mazmuni — bu ongli va ma`naviy tanlovdir. Agar inson haqiqatni sezib turib, eski yolg`onlarga sodiq qolsa, bu sadoqat emas,

vijdonsizlikdir. Shuning uchun Sharafiddinovning e'tiqodini o'zgartirish qarori chinakam ma'naviy jasorat namunasidir deyish mumkin.

### **Ma'naviy jasorat mohiyati**

Sharafiddinov ma'naviy jasoratni faqat tashqi bosimga qarshi turish yoki qo'rqoqlikni yengish sifatida emas, balki ichki haqiqatga sodiq qolish qobiliyati sifatida tushuntiradi. Shubha u uchun xavf emas, aksincha, insonni har bir qarorni ongli ravishda amalga oshirishga undaydigan kuchdir. Muallif o'z xatolarini ochiq tan oladi, bu esa uning ma'naviy jasoratini yanada oshiradi. Shaxsiy tajribasini tarixiy davr muhiti bilan bog'lab, u o'quvchiga faqatgina o'tmishdagi voqealarni tushuntirish bilan cheklanibgina qolmay, bugungi kun uchun ham ma'naviy saboq beradi.

Sharafiddinov ijodida shaxsning ongli mas'uliyati ham muhim o'rin tutadi. Har bir inson o'z e'tiqodi va fikrlari uchun javobgar bo'lishi kerak. Fikrlash va tanlov qilish qobiliyati insonga berilgan eng katta ne'matdir. Shu sababli, har qanday mafkura yoki siyosiy tizim sharoitida ham shaxs mustaqil fikrlashni saqlab qolishi lozim. Insondagi tafakkuriy mas'uliyatning amaliy ifodasi — haqiqatni anglash va unga sodiq qolishdir. Sharafiddinovning maqolasi shuni ko'rsatadiki, e'tiqodni o'zgartirish qarori shaxsning ichki haqiqatga sodiq qolishidagi eng yuqori mas'uliyatdir. Bu qaror nafaqat o'zini oqlash yoki tashqi bosimdan qutulish, balki tarixiy haqiqatni tan olish va vijdon oldida halol bo'lish demakdir.

### **Shaxs va tarix: ma'naviy saboqlar**

Uning e'tiqod va jasorat masalasi shaxsiy tajriba bilan cheklanmaydi. XX asrning o'rta davrlarida yuzaga kelgan totalitar tizim inson ongiga kuchli ta'sir o'tkazgan. Sovet davrida millionlab odamlar mafkura va vijdon o'rtasida tanlov qilishga majbur bo'lgan. Sharafiddinov bu jarayonni "bashariyat tarixidagi eng katta ma'naviy falokatlardan biri" deb baholaydi. Chunki mafkura insonning erkin fikrlash qobiliyatini cheklab, uni tayyor qoliplarga moslashishga majbur etgan. Shu jihatdan qaraganda, muallifning e'tiqodiy o'zgarishi shaxsiy tajribadan tashqari, butun bir avlodning ruhiy uyg'onish jarayonini ifodalaydi. Bu jarayon inson ongida mas'uliyat, erkin tafakkur va vijdon ustuvorligini tiklash yo'lidagi muhim qadam sifatida namoyon bo'ladi. .

Sharafiddinov asarining yana bir muhim jihati shundaki, unda shaxsiy kechinmalar tarixiy voqeliklardan ajralmagan holda yoritiladi. Muallif o'zini faqat sovet tizimi

qurboni sifatida emas, balki erkin fikrlovchi, ongli tanlov qiluvch shaxs sifatida ham tasvirlaydi. Bu esa o'quvchiga shaxsiy tajriba orqali e'tiqod, haqiqat va jasorat masalalarini yanada yaqinroq his qilish imkonini beradi.

Asarda insonning tarix oldidagi mas'uliyati alohida ta'kidlanadi. Har bir shaxs o'z qarashlari va harakatlari bilan jamiyatning ma'naviy qiyofasini shakllantiradi. Shu sababdan e'tiqodiy tanlov faqat shaxsiy masala bo'libgina qolmay, ijtimoiy va tarixiy ahamiyatga ham egadir. Shu nuqtai nazardan maqola nafaqat badiiy, balki tarixiy va falsafiy manba sifatida ham qadrlı.

## **XULOSA**

Shunday qilib, Ozod Sharafiddinovning "E'tiqodimni nega o'zgartirdim?" asari shaxsiy e'tiqod, ma'naviy jasorat va ongli mas'uliyat masalalarini chuqur yoritadi. E'tiqodni o'zgartirish har doim xiyonat emas; ba'zan bu insonning o'z vijdoni oldida halol bo'lishga intilishi, haqiqat sari dadil qadam tashlashi - haqiqiy jasoratidir. Sharafiddinovning jasorati — sadoqatni ong va vijdon bilan uyg'unlashtirish, shubha va haqiqatni qabul qilish orqali mas'uliyatni amalga oshirishdir. Maqola o'quvchiga shaxsiy va tarixiy tajriba orqali e'tiqod, ma'naviy jasorat va ongli mas'uliyatning murakkab va bog'liq tabiatini tushuntiradi. Natijada, Sharafiddinov ijodi bugungi kun yoshlarining ma'naviy kamoloti uchun muhim manba bo'lib, e'tiqod, vijdon va mas'uliyat o'rtasidagi murakkab munosabatlarni anglashga xizmat qiladi. Zero, har bir inson o'z e'tiqodi va haqiqatga sodiqligi bilan jamiyat oldida mas'uliyatni amalga oshirishi kerak. Bu esa nafaqat shaxsiy, balki tarixiy va ijtimoiy javobgarlikni ham o'z ichiga oladi.

## **FOYDALANILGAN ADABIYOTLAR RO'YXATI**

1. "E'tiqodimni nega o'zgartirdim?" maqolasi
2. Rasulov A. iste'dod va e'tiqod. Toshkent, "Sharq" NMK, 2000 y.
3. Karimov I.A. — "Yuksak ma'naviyat — yengilmas kuch" (2008)

## **Smart Tourism Attributes and Tourist Satisfaction: Evidence from Uzbekistan**

**Nasiba Mukhtorova, PhD Candidate, Westminster International University in  
Tashkent, [nmukhtorova@wiut.uz](mailto:nmukhtorova@wiut.uz)**

### **Abstract**

This study examines how smart tourism attributes contribute to tourist satisfaction in Uzbekistan's rapidly digitalizing tourism sector. As the country advances its national digital transformation agenda, understanding the role of smart technologies in enhancing visitor experiences has become increasingly important. The research adopts a qualitative case study approach based on the analysis of national tourism strategies, digital transformation policies, and smart tourism initiatives implemented in Uzbekistan, including electronic visa systems, mobile applications, digital information platforms, and infrastructure modernization programs. Secondary statistical data and official reports were reviewed to assess how these initiatives influence tourist experiences. The findings indicate that key smart tourism attributes accessibility, information quality, interactivity, personalization, and security play a significant role in enhancing tourist satisfaction. Digital initiatives such as simplified visa procedures, mobile travel applications, and improved information systems have increased travel convenience and service efficiency. However, challenges remain in terms of digital literacy gaps, stakeholder coordination, and the integration of smart solutions across regions. The study provides strategic recommendations for policymakers and tourism developers to strengthen digital infrastructure, enhance personalized services, and promote sustainable smart tourism development. By offering a comprehensive case-based analysis of Uzbekistan's digital transformation in tourism, this research

contributes to the limited literature on smart tourism development in Central Asia and highlights its implications for improving tourist satisfaction.

## **Keywords**

Smart tourism, tourist satisfaction, digital transformation, tourism development, Uzbekistan

## **1. Introduction**

Digital transformation has significantly reshaped the global tourism industry. The emergence of smart tourism, driven by information and communication technologies (ICT), big data, and digital platforms, has enabled destinations to enhance visitor experiences and improve competitiveness [1]. Smart tourism attributes such as accessibility, information quality, interactivity, personalization, and security are increasingly recognized as key determinants of tourist satisfaction [2].

Uzbekistan, as an emerging tourism destination in Central Asia, has undertaken substantial digital reforms in recent years. National development strategies emphasize digitalization as a driver of socio-economic growth [3]. This study explores how smart tourism attributes contribute to tourist satisfaction in Uzbekistan through a case-based analysis of national digital tourism initiatives.

## **2. Conceptual Background**

Smart tourism has emerged as an evolution of traditional tourism systems through the integration of information and communication technologies (ICT), big data analytics, artificial intelligence, and Internet of Things (IoT) applications into tourism services and destination management [4]. The concept originates from the broader framework

of smart cities, where digital infrastructures and data-driven governance mechanisms are used to enhance efficiency, sustainability, and quality of life [5].

Unlike conventional tourism models, smart tourism emphasizes interconnected systems, real-time data exchange, and collaborative value creation among stakeholders. Digital platforms enable tourists to access accurate information, plan trips efficiently, engage interactively with service providers, and personalize their travel experiences. According to Sunpang et al. (2024), the integration of AI and IoT technologies plays a critical role in building sustainable smart tourism destinations by enabling intelligent decision-making and optimized resource allocation.

## **2.1 Smart Tourism Attributes**

In the literature, smart tourism is often operationalized through specific attributes that shape the tourist experience. Key attributes include accessibility, information quality, interactivity, personalization, and security [6].

**Accessibility** refers to the ease with which tourists can obtain digital services and travel-related information. This includes online visa systems, digital booking platforms, mobile applications, and transportation integration. Improved accessibility reduces uncertainty and enhances convenience.

**Information Quality** concerns the accuracy, reliability, timeliness, and relevance of tourism-related information provided through digital channels. High-quality information supports informed decision-making and reduces perceived risk during travel.

**Interactivity** reflects the level of communication and engagement between tourists and service providers via digital platforms. Interactive systems enable real-time feedback, personalized recommendations, and improved service responsiveness.

**Personalization** involves the customization of services based on tourists' preferences, travel history, and behavioral data. Personalized recommendations enhance perceived value and emotional engagement.

**Security** refers to safe digital transactions, data protection, and privacy assurance. Secure systems build trust, which is essential for digital service adoption [7].

These attributes collectively contribute to shaping tourists' perceptions of service quality and destination competitiveness.

## **2.2 Smart Tourism and Tourist Satisfaction**

Tourist satisfaction is a central outcome variable in tourism research, influencing loyalty, revisit intention, and positive word-of-mouth. In smart tourism contexts, satisfaction is influenced not only by physical infrastructure but also by digital service performance.

Empirical research suggests that smart tourism technologies significantly affect travel satisfaction by improving efficiency, reducing information asymmetry, and enhancing experiential quality [6]. Similarly, Wei et al. (2024) demonstrate that smart destination attributes positively influence overall life satisfaction through improved tourism experiences [8].

Smart tourism attributes can enhance satisfaction in three primary ways:

1. **Functional enhancement** – simplifying planning and navigation
2. **Emotional engagement** – creating immersive and interactive experiences
3. **Perceived value creation** – increasing convenience and service efficiency

Thus, the integration of digital systems strengthens the relationship between destination services and positive tourist outcomes.

### **2.3 Smart Tourism and Sustainable Development**

Beyond customer satisfaction, smart tourism is increasingly linked to sustainability objectives. Digital technologies allow destinations to monitor tourist flows, optimize resource usage, and implement environmentally responsible policies [9].

Smart systems reduce paper-based processes, enhance energy efficiency, and support data-driven governance. In emerging economies, digital tourism strategies are often embedded within broader national development frameworks aimed at modernization and economic diversification. In this context, smart tourism represents not only a technological transformation but also a strategic pathway toward sustainable and competitive tourism development.

## **3. Methodology**

### **3.1 Research Design**

This study adopts a qualitative case study research design to examine the development of smart tourism attributes and their influence on tourist satisfaction in Uzbekistan. A case study approach is appropriate when investigating contemporary phenomena within real-life contexts, particularly where the boundaries between the phenomenon and its environment are not clearly defined [10]. Smart tourism development in

Uzbekistan represents a context-dependent process shaped by national policies, digital transformation strategies, and institutional reforms.

The case study method allows for an in-depth exploration of how smart tourism attributes are implemented at the destination level and how they contribute to improving tourist experiences.

### **3.2 Data Collection**

The study relies primarily on secondary data sources. Secondary data analysis is particularly suitable for policy-oriented and development-focused research, as it enables the systematic examination of existing documents, reports, and official statistics [11].

Data sources include:

- National tourism development strategies
- Digital transformation policy documents (e.g., “Digital Uzbekistan–2030”)
- Government publications and official reports
- Statistical data from national tourism authorities
- Industry reports and publicly available tourism performance indicators
- Academic literature on smart tourism and digital transformation

These sources provide comprehensive insights into the evolution of smart tourism initiatives and their strategic objectives.

### **3.3 Analytical Approach**

The collected data were analyzed using a thematic analysis approach. The analysis focused on identifying how key smart tourism attributes—accessibility, information quality, interactivity, personalization, and security—are reflected in Uzbekistan’s tourism policies and digital initiatives.

Thematic analysis allows researchers to systematically interpret qualitative data and identify patterns related to strategic priorities and practical implementation [12]. The analytical process involved:

1. Reviewing policy and strategy documents
2. Identifying references to digital transformation and smart initiatives
3. Categorizing initiatives according to smart tourism attributes
4. Evaluating their potential contribution to tourist satisfaction

This structured analytical framework ensures conceptual consistency between theoretical constructs and real-world policy implementation.

#### **4. Findings: Smart Tourism Attributes in Uzbekistan**

The case analysis reveals that Uzbekistan has made significant progress in integrating smart tourism attributes into its national tourism development strategy. The findings are structured according to the five key smart tourism attributes identified in the conceptual framework: accessibility, information quality, interactivity, personalization, and security. Accessibility represents one of the most visible smart tourism attributes in Uzbekistan’s digital transformation process. The introduction of the electronic visa (e-visa) system has significantly simplified entry procedures for international visitors and reduced administrative barriers [13]. Recent statistical data indicate a substantial increase in foreign tourist arrivals, reflecting improved international accessibility

(“Uzbekistan sees 48% surge in foreign tourist arrivals”, 2025). Uzbekistan has developed official tourism portals and mobile applications that provide structured and multilingual information about cultural heritage sites and services. High-quality digital information systems are considered essential in smart tourism environments [2]. Interactive communication between tourists and service providers is facilitated through digital platforms and online systems. Research indicates that interactivity significantly enhances user engagement and satisfaction in smart tourism contexts [6].

Personalization initiatives reflect the gradual integration of data-driven tourism management systems. Smart tourism literature highlights personalization as a key determinant of destination competitiveness [4]. Secure digital transactions and governance frameworks are essential components of smart tourism ecosystems. Uzbekistan’s digital governance reforms aim to strengthen institutional reliability and procedural security.

## **5. Discussion**

The findings of this case study demonstrate that Uzbekistan’s smart tourism initiatives reflect the core attributes identified in smart tourism literature. The implementation of digital systems such as e-visas, national tourism platforms, and infrastructure modernization aligns with theoretical frameworks that define smart tourism as the integration of ICT, real-time information exchange, and innovation-driven governance. From an analytical perspective, accessibility emerges as the foundational attribute within Uzbekistan’s smart tourism transformation. Information quality also plays a critical role in shaping positive travel experiences. The availability of structured, multilingual, and real-time digital information reduces information asymmetry and enhances tourists’ sense of control during travel. This finding supports existing

empirical studies demonstrating that reliable digital information systems significantly influence travel satisfaction and destination perception. Interactivity and personalization, while still developing, indicate a transition toward more experience-centered tourism management. Smart tourism literature emphasizes that digital engagement and customized services enhance emotional connection and perceived value. In the case of Uzbekistan, interactive platforms and emerging personalized services suggest movement toward value co-creation between tourists and service providers. However, the uneven integration of advanced personalization technologies suggests that the smart tourism ecosystem remains in a developmental phase.

Security, particularly in digital transactions and governance, functions as a trust-building mechanism. Trust is essential for technology adoption and digital engagement in tourism environments. By strengthening institutional digital frameworks, Uzbekistan reinforces tourists' confidence in online services, which indirectly supports satisfaction and repeat visitation. Importantly, the findings indicate that smart tourism development in Uzbekistan is not limited to technological modernization but is embedded within broader national digital transformation strategies. Digital solutions contribute not only to operational efficiency but also to resource optimization, reduced administrative burden, and enhanced transparency.

Overall, the discussion suggests that smart tourism attributes in Uzbekistan positively contribute to tourist satisfaction, but the long-term effectiveness of these initiatives depends on sustained investment, institutional coordination, and inclusive digital policies.

## **6. Conclusion**

This study examined the role of smart tourism attributes in shaping tourist satisfaction in Uzbekistan within the context of national digital transformation. Using a qualitative case study approach, the research explored how accessibility, information quality, interactivity, personalization, and security are reflected in Uzbekistan's tourism development initiatives.

The findings indicate that Uzbekistan has made substantial progress in integrating digital technologies into its tourism ecosystem. The implementation of e-visa systems, digital information platforms, infrastructure modernization, and governance reforms demonstrates alignment with the core dimensions of smart tourism identified in contemporary literature. These initiatives contribute to improved travel convenience, reduced uncertainty, enhanced service efficiency, and increased visitor confidence — all of which are key drivers of tourist satisfaction.

The study contributes to the growing body of smart tourism research by providing evidence from an emerging Central Asian destination, a region that remains underrepresented in academic discourse. It highlights that smart tourism development in emerging economies is not solely a technological shift but also a strategic governance process embedded within broader socio-economic transformation agendas.

From a practical perspective, the findings suggest that policymakers should prioritize integrated digital ecosystems, stakeholder collaboration, and continuous infrastructure investment to sustain smart tourism growth. Strengthening personalization technologies, enhancing cybersecurity frameworks, and addressing regional disparities in digital development will be essential for long-term competitiveness.

In conclusion, smart tourism attributes play a strategic role in positioning Uzbekistan as a digitally advanced and competitive destination. Continued innovation, institutional

coordination, and inclusive digital policies will determine the extent to which smart tourism can fully contribute to sustainable tourism development and enhanced tourist satisfaction in the future.

### References

- [1] D. Buhalis and A. Amaranggana, “Smart Tourism Destinations Enhancing Tourism Experience Through Personalisation of Services,” *Inf. Commun. Technol. Tour.* 2015, no. February, pp. 377–389, 2015, doi: 10.1007/978-3-319-14343-9\_28.
- [2] W. Wei, I. Önder, and M. Uysal, “Smart tourism destination (STD): developing and validating an impact scale using residents’ overall life satisfaction,” *Curr. Issues Tour.*, vol. 27, no. 17, pp. 2849–2872, 2024, doi: 10.1080/13683500.2023.2296587.
- [3] “Uzbekistan Digital Economy Overview and Vision 2030,” 2024.
- [4] J. Liu, C. M. Hall, C. Zhu, and V. Ting Pong Cheng, “Redefining the concept of smart tourism in tourism and hospitality,” *Anatolia*, vol. 35, no. 3, pp. 566–578, 2024, doi: 10.1080/13032917.2023.2282712.
- [5] M. Vasavada and Y. J. Padhiyar, “Smart Tourism»: Growth for Tomorrow,” *J. Res. Vol.*, vol. 01, no. 12, pp. 55–61, 2016, [Online]. Available: <https://www.academia.edu/download/46189656/J4RV1I12021.pdf>
- [6] W. Qian, I. Halidin, and F. I. Anuar, “The Influence of Smart Tourism Technologies (STTs) Attributes on Domestic Tourists’ Travel Satisfaction and Revisit Intention: Evidence from Bali,” *Int. J. Acad. Res. Bus. Soc. Sci.*, vol. 13, no. 5, 2023, doi: 10.6007/ijarbss/v13-i5/17053.
- [7] Y. Zhang, M. Sotiriadis, and S. Shen, “Investigating the Impact of Smart

- Tourism Technologies on Tourists' Experiences,” *Sustainability (Switzerland)*, vol. 14, no. 5, 2022, doi: 10.3390/su14053048.
- [8] A. M. Elshaer and A. M. Marzouk, “Memorable tourist experiences: the role of smart tourism technologies and hotel innovations,” *Tour. Recreat. Res.*, vol. 49, no. 3, pp. 445–457, 2024, doi: 10.1080/02508281.2022.2027203.
- [9] E. Samancioglu, S. Kumlu, and E. Ozkul, “Smart tourism destinations and sustainability: evidence from the tourism industry,” *Worldw. Hosp. Tour. Themes*, vol. 16, no. 6, pp. 680–693, 2024, doi: 10.1108/WHATT-07-2024-0167.
- [10] J. W. Creswell, “Research Approaches and Designs,” *Res. Des.*, pp. 89–89, 2009, doi: 10.5005/jp/books/13016\_6.
- [11] M. P. Johnston, “Secondary Data Analysis : A Method of which the Time Has Come,” *Qual. Quantative Methods Libr.*, vol. 3, pp. 619–626, 2014.
- [12] L. Saunders, MarkPhilip and A. Thornhill, *Research Methods for Business Students*. 2019.
- [13] F. Khamdamova, “Жамият ва инновациялар – Общество и инновации – Society and innovations Strategy " Digital Uzbekistan-2030 ": prerequisites for adoption , main provisions , mechanisms and prospects for implementation ‘ Рақамли Ўзбекистон -2030 ’ стратегияси : қабул қилиш,” 2020.

**STRENGTH AND CRACK RESISTANCE OF BASALT FIBER-  
STRENGTHENED REINFORCED CONCRETE BEAMS WITH  
COMPOSITE REINFORCEMENT: A COMPARATIVE ANALYSIS  
BASED ON EUROCODE 2**

**Muxtorova Shahzoda Shokirjon qizi**

Fergana State Technical University, Faculty of Architecture and Construction Master's  
student of group M2-25 QM

Scientific supervisor: **Nazirov Ayubxon Sultonjon o'g'li**  
Senior Lecturer, Department of Construction Materials (QM),  
Fergana State Technical University

**Abstract:**

This paper presents a theoretical analysis of the strength and crack resistance of flexural reinforced concrete beams reinforced with composite FRP bars and strengthened by basalt fibers. Although FRP reinforcement provides high tensile strength and excellent corrosion resistance, its relatively low modulus of elasticity compared to steel reinforcement leads to increased deflections and crack widths, which is considered a key serviceability limitation. The incorporation of basalt fibers into concrete is examined as an effective method to improve crack resistance by acting as micro-reinforcement, bridging microcracks and limiting crack propagation. Furthermore, the Eurocode 2 crack width calculation approach is reviewed and compared with the structural behavior of FRP reinforced concrete members. Based on the reviewed literature, the combined use of basalt fibers and FRP reinforcement is identified as a promising solution for

enhancing serviceability performance, durability, and long-term reliability of reinforced concrete beams in aggressive environments.

**Keywords:** basalt fiber, FRP reinforcement, composite rebar, reinforced concrete beam, flexural behavior, crack resistance, strength, deflection, Eurocode

**Annotatsiya:** Ushbu maqolada basalt fibra bilan mustahkamlangan hamda kompozit armatura (FRP) bilan armaturalangan egilishga ishlovchi temir-beton to'sinlarning mustahkamligi va yoriqbardoshligi nazariy jihatdan tahlil qilinadi. FRP armaturalarning yuqori tortilish mustahkamligi va korroziyaga chidamliligi kabi afzalliklariga qaramasdan, ularning elastiklik moduli po'lat armaturaga nisbatan past bo'lgani sababli egilish deformatsiyalari va yoriq kengliklari ortishi muammo sifatida qaraladi. Ushbu kamchiliklarni kamaytirishda basalt fibra beton tarkibida mikroarmatura vazifasini bajarib, yoriqlarning hosil bo'lishi va rivojlanishini cheklashi asoslab beriladi. Shuningdek, Eurocode 2 me'yoriy hujjati bo'yicha yoriq kengligini aniqlash metodikasi keltiriladi hamda FRP armaturali elementlarda ushbu yondashuvni qo'llashdagi farqli jihatlar tahlil qilinadi. Adabiyotlar sharhi natijalariga ko'ra basalt fibra va FRP armatura kombinatsiyasi temir-beton to'sinlarning xizmat holati ko'rsatkichlarini yaxshilash, yoriqbardoshlikni oshirish va ekspluatatsion ishonchlikni ta'minlashda istiqbolli yechim hisoblanadi.

**Kalit so'zlar:** basalt fibra, FRP armatura, kompozit armatura, temir-beton to'sin, egilish, yoriqbardoshlik, mustahkamlik, deformatsiya, Eurocode 2.

Kirish

Hozirgi kunda temir-beton konstruksiyalarni loyihalashda nafaqat mustahkamlikni, balki uzoq muddatli ekspluatatsion holatni ta'minlash ham muhim talab hisoblanadi.

Temir-beton inshootlarning asosiy muammolaridan biri po'lat armaturaning korroziyaga uchrashi bo'lib, bu jarayon beton qoplamaning yorilishi, armatura kesimining kamayishi va natijada elementning yuk ko'tarish qobiliyatining

pasayishiga olib keladi. Ayniqsa nam muhit, sho‘rlangan tuproq yoki kimyoviy agressiv sharoitda ishlovchi inshootlarda korroziya jarayoni tezlashadi va xizmat muddati keskin kamayadi.

Shu sababli zamonaviy qurilish amaliyotida po‘lat armaturaga alternativ sifatida kompozit armaturalar, jumladan shisha tolali (GFRP), basalt tolali (BFRP) va uglerod tolali (CFRP) armaturalar keng qo‘llanilmoqda. Ushbu armaturalarning asosiy afzalligi korroziyaga chidamliligi, yengil vazni va yuqori tortilish mustahkamligi bilan izohlanadi.

Biroq FRP armaturalarning elastiklik moduli po‘lat armaturaga nisbatan sezilarli darajada kichik bo‘lgani sababli egilishga ishlovchi temir-beton elementlarda deformatsiya ortishi va yoriq kengligining oshishi kuzatiladi. Bu holat xizmat holati (serviceability limit state) bo‘yicha normativ talablarni qondirishni murakkablashtiradi.

Ushbu muammoni kamaytirishning istiqbolli yo‘nalishlaridan biri beton tarkibiga basalt fibra qo‘shish orqali betonning tortilish zonasidagi ish qobiliyatini oshirishdan iborat. Basalt fibra beton ichida dispers armatura vazifasini bajarib, yoriqlar hosil bo‘lishini kechiktiradi, yoriqlar kengligini kamaytiradi hamda betonning yorilishga chidamliligini oshiradi.

Mazkur maqolada basalt fibra bilan mustahkamlangan FRP armaturali temir-beton to‘sinlarning mustahkamligi va yoriqbardoshligi bo‘yicha mavjud ilmiy yondashuvlar tahlil qilinadi hamda Eurocode 2 me‘yoriy hujjati asosida solishtirma baholash keltiriladi.

## 2. Adabiyotlar tahlili

So‘nggi yillarda FRP armaturali temir-beton elementlarning mexanik xususiyatlari bo‘yicha ko‘plab tadqiqotlar olib borilgan. Tadqiqotlar shuni ko‘rsatadiki, FRP armatura bilan armaturalangan elementlarda yoriqlanish jarayoni po‘lat armaturali

elementlarga nisbatan tezroq sodir bo‘ladi. Bu holat FRP armaturaning elastiklik moduli pastligi bilan izohlanadi.

ACI 440 va fib Model Code tavsiyalariga ko‘ra FRP armaturali elementlarda mustahkamlikdan ko‘ra ko‘proq xizmat holati mezonlari – deformatsiya va yoriq kengligini nazorat qilish muhimroq hisoblanadi. Shuningdek, FRP armatura mo‘rt buzilish xarakteriga ega bo‘lib, deformatsiya bo‘yicha ogohlantirishsiz uzilishi mumkin.

Basalt fibra bilan mustahkamlangan beton bo‘yicha tadqiqotlarda esa basalt tolalar betonning yorilishga chidamliligini oshirishi, mikro yoriqlarni bog‘lab turishi va betonning energiya yutish qobiliyatini oshirishi qayd etilgan. Basalt fibra qo‘shilgan betonlarda yoriqlar soni ortadi, ammo yoriqlar kengligi sezilarli darajada kamayadi. Adabiyotlar tahlili shuni ko‘rsatadiki, FRP armatura va basalt fibra kombinatsiyasi yoriqbardoshlikni oshirish hamda deformatsiyani kamaytirish bo‘yicha samarali yechim hisoblanadi.

### 3. Kompozit armaturaning egilishga ishlovchi elementlardagi xususiyatlari

FRP armaturaning po‘lat armaturadan asosiy farqlari quyidagilar bilan tavsiflanadi:

Elastiklik moduli pastligi: po‘lat armaturada taxminan 200 GPa, GFRP armaturada esa odatda 40–60 GPa atrofida.

Mo‘rt buzilish: FRP armatura plastiklikka ega emas, oqish bosqichi kuzatilmaydi.

Korroziyaga chidamlilik: agressiv muhitlarda yuqori barqarorlik.

Yengil vazn: transport va montaj jarayonlarini yengillashtiradi.

Egilishga ishlovchi temir-beton to‘sinlarda yoriqlanish tortilish zonasida boshlanadi.

Po‘lat armaturali elementlarda armatura elastik-plastik xususiyatlari tufayli deformatsiya jarayoni bosqichma-bosqich rivojlanadi. FRP armaturali elementlarda esa deformatsiya tez ortib, yoriqlar kengligi katta bo‘lishi mumkin.

Shuning uchun FRP armatura bilan armaturalangan to‘sinlarda yoriqbardoshlik va deformatsiyani cheklash dolzarb masala bo‘lib qolmoqda.

Basalt fibraning beton tarkibidagi ro‘li - Basalt fibra tabiiy vulqon jinslaridan olinadigan tolali material bo‘lib, beton tarkibida dispers armatura vazifasini bajaradi. Basalt tolalarining mexanik xususiyatlari yuqori bo‘lib, ularning beton ichida tarqalishi betonning cho‘zilish zonasidagi kuchlanishlarni qayta taqsimlash imkonini beradi.

Basalt fibra betonning quyidagi xususiyatlarini yaxshilaydi:

betonning yorilishga chidamliligi oshadi;

yoriqlarning rivojlanish tezligi pasayadi;

yoriq kengligi kamayadi;

betonning energiya yutish qobiliyati ortadi;

deformatsiya jarayoni barqarorlashadi.

Basalt fibra beton ichida “ko‘prik effekti” (bridging effect) hosil qilib, mikro yoriqlarni birlashtirib turadi va ularning katta yoriqqa aylanishiga to‘sqinlik qiladi. Bu esa FRP armaturali to‘sinlarda xizmat holatini yaxshilashda muhim rol o‘ynaydi.

Basalt fibra va FRP armatura kombinatsiyasining samaradorligi - FRP armaturali temir-beton to‘sinlarda deformatsiya va yoriqlanish muammosi betonning tortilish zonasida tez yorilishi bilan bog‘liq. Basalt fibra qo‘shilganda betonning tortilish zonasida qo‘shimcha mustahkamlik hosil bo‘ladi.

Ushbu kombinatsiya natijasida quyidagi samaralar kuzatiladi:

birinchi yoriq hosil bo‘lishi kechikadi;

yoriqlar soni ortadi, lekin yoriqlar kengligi kamayadi;

to‘sinning egilish deformatsiyasi kamayadi;

elementning yorilishdan keyingi qattiqligi nisbatan yuqoriroq saqlanadi;

mo‘rt buzilish xavfi kamayadi.

Demak, basalt fibra FRP armaturali elementlarda xizmat holati ko'rsatkichlarini yaxshilovchi qo'shimcha mustahkamlovchi komponent sifatida qaraladi.

Eurocode 2 bo'yicha yoriq kengligini hisoblash (Crack Width Calculation According to Eurocode 2)

Eurocode 2 (EN 1992-1-1) me'yoriy hujjatida yoriq kengligini aniqlash uchun quyidagi asosiy formula beriladi:

$$w_k = s_{r,max}(\epsilon_{sm} - \epsilon_{cm})$$

bu yerda:

$w_k$  – xarakterli yoriq kengligi (mm);

$s_{r,max}$  – maksimal yoriqlar oralig'i (mm);

$\epsilon_{sm}$  – armaturaning o'rtacha deformatsiyasi;

$\epsilon_{cm}$  – betonning o'rtacha deformatsiyasi.

Eurocode 2 bo'yicha maksimal yoriqlar oralig'i quyidagicha ifodalanadi:

$$s_{r,max} = k_{3c} + k_1 k_2 k_4 (\phi / \rho_p, eff \phi)$$

bu yerda:

$c$  – beton qoplama qalinligi (mm);

$\phi$  – armatura diametri (mm);

$\rho_p, eff$  – samarali armaturalash koeffitsiyenti;

$k_1, k_2, k_3, k_4$  – empirik koeffitsiyentlar.

Eurocode 2 formulalari po'lat armaturali temir-beton elementlar uchun ishlab chiqilgan bo'lib, FRP armaturali elementlarda elastiklik moduli farqi sababli deformatsiya ko'rsatkichlari o'zgaradi.

7. Eurocode 2 va FRP armatura yondashuvlarini solishtirish (Comparison of Eurocode 2 and FRP-Based Design Approaches)

Eurocode 2 asosan po‘lat armatura uchun mo‘ljallangan bo‘lib, armaturaning plastiklik xususiyatiga tayanadi. FRP armatura esa elastik va mo‘rt buzilish xususiyatiga ega.

Solishtirma jihatlar

#### 1. Elastiklik moduli farqi

Po‘lat armaturada  $E_s \approx 200$  GPa, FRP armaturada esa  $E_{frp}$  odatda 40–70 GPa. Bu holat deformatsiyani oshiradi.

#### 2. Yoriq kengligi

Eurocode 2 formulalarida yoriq kengligi armatura deformatsiyasiga bog‘liq. FRP armaturada deformatsiya katta bo‘lgani sababli:

$$W_{FRP} > W_{Steel}$$

#### 3. Deformatsiya nazorati

Eurocode 2 bo‘yicha deformatsiya inertsia momentining o‘zgarishi asosida baholanadi. FRP armaturali elementlarda yoriqlanishdan keyingi qattqlik keskin pasayadi.

#### 4. Buzilish xarakteri

Po‘lat armaturada avval armatura oqadi, keyin beton eziladi. FRP armaturada esa uzilish birdan sodir bo‘ladi.

Shuning uchun FRP armaturali elementlarda xizmat holati bo‘yicha hisoblashlar kuchaytirilgan nazoratni talab qiladi.

#### 8. Basalt fibra qo‘shishning Eurocode 2 nuqtai nazaridan ta’siri (Effect of Basalt Fibers in Terms of Eurocode 2 Serviceability Requirements)

Eurocode 2 bo‘yicha yoriq kengligi quyidagi asosiy omillarga bog‘liq:

yoriqlar oralig‘i  $s_r, max$ ,

armatura deformatsiyasi  $\epsilon_{sm}$ ,

beton deformatsiyasi  $\epsilon_{cm}$ .

Basalt fibra beton tarkibida mikroarmatura sifatida ishlagani sababli yoriqlar oralig‘i kamayishi hamda betonning tortilish zonasidagi deformatsiyasi oshishi mumkin. Bu holat:

$$W_{k=S_{r,max}}(\varepsilon_{sm}-\varepsilon_{cm})$$

ifodasida  $s_{r,max}$  kamayishiga olib keladi va natijada yoriq kengligi pasayadi.

Shuningdek, basalt fibra yoriqlanishdan keyingi betonning ish qobiliyatini saqlab qoladi. Bu esa FRP armaturali to‘sinlarda deformatsiyani kamaytiruvchi muhim omil bo‘lib xizmat qiladi.

Mustahkamlikka ta’siri. Egilishga ishlovchi temir-beton to‘sinlarning mustahkamligi asosan betonning siqilish zonasidagi mustahkamligi hamda armaturaning tortilish zonasidagi ish qobiliyatiga bog‘liq. FRP armatura yuqori tortilish mustahkamligiga ega bo‘lsa-da, uning elastiklik moduli pastligi sababli yoriqlanishdan keyingi bosqichda deformatsiya ortadi. Basalt fibra esa betonning tortilish zonasida qo‘shimcha mustahkamlik hosil qilib, elementning ish rejimini yaxshilaydi. Adabiyotlarda basalt fibra qo‘shilgan betonning egilishga mustahkamligi va yorilishga chidamliligi oshishi qayd etilgan. Shu sababli basalt fibra FRP armaturali elementlarda mustahkamlikni oshirishdan ko‘ra ko‘proq xizmat holatini yaxshilashga ta’sir qiladi.

Yoriqbardoshlik va deformatsiya nazorati. FRP armaturali elementlarda yoriqlar kengligi katta bo‘lishi, deformatsiya esa normativ qiymatdan oshib ketishi mumkin. Basalt fibra qo‘shilganda yoriqlar soni ko‘payadi, lekin ularning kengligi kamayadi. Bu holat yoriqlanishni yanada barqaror qiladi.

Bunday elementlarning asosiy afzalligi shundaki, basalt fibra va FRP armatura kombinatsiyasi:

yoriq kengligini cheklaydi,  
deformatsiyani kamaytiradi,

elementning ekspluatatsion barqarorligini oshiradi.

Nazariy tahlillar shuni ko'rsatadiki, FRP armaturali temir-beton to'sinlarning mustahkamligi ko'pincha yuqori bo'lsa-da, ularning xizmat holati ko'rsatkichlari (deformatsiya va yoriq kengligi) cheklovchi omil hisoblanadi. Eurocode 2 yondashuvi po'lat armatura uchun ishlab chiqilgan bo'lib, FRP armatura qo'llanilganda deformatsiya ortishi sababli yoriq kengligi hisoblari yuqori qiymat berishi mumkin. Basalt fibra qo'shish esa yoriqlar rivojlanishini cheklab, xizmat holatini yaxshilaydi. Shuningdek, basalt fibra betonning yoriqlanishdan keyingi ish qobiliyatini saqlab qolishi hisobiga elementning qattiqligi nisbatan yuqori bo'lib qoladi.

#### Xulosa

FRP armaturali temir-beton to'sinlar korroziyaga chidamlilik va yuqori tortilish mustahkamligi bo'yicha po'lat armaturaga nisbatan afzalliklarga ega.

FRP armaturaning elastiklik moduli pastligi sababli egilish deformatsiyasi va yoriq kengligi ortishi xizmat holati bo'yicha asosiy cheklov hisoblanadi.

Basalt fibra beton tarkibida mikroarmatura vazifasini bajarib, yoriqlar hosil bo'lishi va rivojlanishini cheklaydi hamda yoriq kengligini kamaytiradi.

Eurocode 2 bo'yicha yoriq kengligi hisoblash formulalari armatura deformatsiyasiga bog'liq bo'lib, FRP armatura qo'llanilganda yoriq kengligi yuqori chiqishi mumkin.

Basalt fibra qo'shish natijasida yoriqlar oralig'i va yoriq kengligi kamayib, FRP armaturali to'sinlarning ekspluatatsion ko'rsatkichlari yaxshilanadi.

FRP armatura va basalt fibra kombinatsiyasi agressiv muhitlarda ishlovchi temir-beton konstruksiyalar uchun istiqbolli va samarali yechim hisoblanadi.

#### **Foydalanilgan adabiyotlar (References)**

EN 1992-1-1: Eurocode 2: Design of Concrete Structures – Part 1-1: General Rules and Rules for Buildings.

ACI 440.1R-15: Guide for the Design and Construction of Structural Concrete Reinforced with FRP Bars.

fib Model Code for Concrete Structures 2010.

CSA S806-12: Design and Construction of Building Components with Fibre-Reinforced Polymers.

Bank L.C. Composites for Construction: Structural Design with FRP Materials. Wiley, 2006.

Teng J.G., Chen J.F., Smith S.T., Lam L. FRP-Strengthened RC Structures. Wiley, 2002.

Nanni A., De Luca A. Reinforced Concrete with FRP Bars: Mechanics and Design. CRC Press.

Neville A.M. Properties of Concrete. Pearson Education.

Mehta P.K., Monteiro P.J.M. Concrete: Microstructure, Properties and Materials.

Sim J., Park C., Moon D.Y. Characteristics of basalt fiber as a strengthening material for concrete structures.

Dias D.P., Thaumaturgo C. Fracture toughness of basalt fiber reinforced concrete composites.

Branston J., Das S., Kenno S.Y., Taylor C. Mechanical behaviour of basalt fibre reinforced concrete.

Almusallam T.H. Load-deflection behavior of FRP reinforced concrete beams.

Benmokrane B., El-Salakawy E. Design of FRP reinforced concrete structures.

RILEM TC 162-TDF: Test and design methods for fibre reinforced concrete.

Li V.C. Engineered Cementitious Composites (ECC): Material, Structural, and Durability Performance.

Hassan T., Rizkalla S. Serviceability of FRP reinforced concrete beams.

El Refai A., Abed F., Altalmas A. Crack width prediction of FRP RC beams.

- Toutanji H., Saafi M. Durability of FRP reinforced concrete in harsh environments.
- Pacheco-Torgal F., Jalali S. Cementitious building materials reinforced with fibres.
- Kim J.K., Kim D.J. Flexural behavior of fiber reinforced concrete beams.
- Gao D., Zhang L. Crack control behavior of fiber reinforced concrete beams.
- Wang Y., Wu H.C., Li V.C. Concrete reinforcement with fibers.
- CEB-FIP Model Code 1990.
- ACI Committee 544. Report on Fiber Reinforced Concrete.
- ASTM C1609: Standard Test Method for Flexural Performance of Fiber-Reinforced Concrete.
- Mindess S., Young J.F., Darwin D. Concrete. Prentice Hall.
- Barros J.A.O., Figueiras J.A. Crack width control in fiber reinforced concrete.
- Rakhshanimehr M., et al. Mechanical performance of basalt fiber reinforced concrete.
- Zollo R.F. Fiber-reinforced concrete: an overview.

## **The Role of Ecotourism and Its Prospective Directions in Uzbekistan's Tourism Sector**

**Choriyeva Nargiza Ibotovna**

*Phd student*

Uzbek State World Languages University

**Annotation:** Uzbekistan possesses rich natural resources, diverse landscapes, and unique ecosystems, providing great opportunities for ecotourism development. Tourism contributes not only to economic benefits, creation of new jobs, and increasing foreign currency inflows but also plays a significant role in addressing social, cultural, and political issues. Therefore, studying tourism from a scientific perspective and developing sustainable development strategies in regions is of great importance.

**Key words:**

Ecotourism, Sustainable development, Tourism potential, Bostanliq district, Tourism infrastructure, Domestic and international tourism

### **O'ZBEKISTON TURIZM SOHASIDA EKOTURIZMNING ROLI VA ISTIQBOLLI YO'NALISHLARI**

**Choriyeva Nargiza Ibotovna**

O'zbekiston davlat jahon tillari universiteti

1-bosqich tayanch doktoranti

[choryevanargiza257@gmail.com](mailto:choryevanargiza257@gmail.com)

+998931708807

**ANNOTATSIYA:** O'zbekiston boy tabiiy resurslar, turli landshaftlar va noyob ekotizimlarga ega bo'lib, ekoturizmni rivojlantirish uchun katta imkoniyatlarga ega. Turizm sohasi nafaqat iqtisodiy foyda, yangi ish o'rinlari va valyuta tushumini

o'shishga xizmat qiladi, balki ijtimoiy, madaniy va siyosiy masalalarning samarali hal etilishiga ham yordam beradi. Shu bois, O'zbekiston turizmini ilmiy nuqtai nazardan o'rganish va hududlarda barqaror rivojlanish strategiyalarini ishlab chiqish muhimdir.

**Kalit so'zlar:** Ekoturizm, Barqaror rivojlanish, Turizm salohiyati, Turizm infratuzilmasi, Ichki va xalqaro turizm

### **Роль экотуризма и перспективные направления в туристической отрасли Узбекистана**

*Чориева Наргиза Иботовна*

*базовый докторант*

Узбекский государственный университет мировых языков

**Аннотация:** Узбекистан обладает богатым природным потенциалом, разнообразными ландшафтами и уникальными экосистемами, создавая большие возможности для развития экотуризма. Туризм способствует не только экономической выгоде, созданию новых рабочих мест и увеличению валютных поступлений, но и эффективному решению социальных, культурных и политических вопросов. Поэтому научное изучение туризма и разработка стратегий устойчивого развития в регионах является актуальной задачей.

**Ключевые слова:** Экотуризм, Устойчивое развитие, Туристический потенциал, Район Бостанлык, Туристическая инфраструктура, Внутренний и международный туризм

#### **Dolzarbligi**

O'zbekiston tabiiy boyliklari, turli landshaftlari va noyob ekotizimlari bilan nafaqat

Markaziy Osiyoda, balki jahon miqyosida ekoturizmni rivojlantirish uchun katta salohiyatga ega. Turizm sohasi mamlakat iqtisodiyotining muhim tarmoqlaridan biri bo‘lib, u yangi ish o‘rinlarini yaratish, aholi farovonligini oshirish, valyuta tushumlarini ko‘paytirish va turizm infratuzilmasini rivojlantirish imkonini beradi. Shu bilan birga, turizm ijtimoiy, madaniy va ekologik masalalarni hal etishda ham samarali vosita hisoblanadi.

O‘zbekistonda turizm sohasi rivojlanishi uchun barcha sharoit va imkoniyatlar mavjud. Ushbu soha yangi ish o‘rinlarini yaratish, aholi farovonligini oshirish, valyuta va soliq tushumlari ko‘payishida muhim ahamiyatga ega[1.142]. Demak, turizm sohasi o‘zining ijtimoiy-iqtisodiy, madaniy, hatto, siyosiy sohadagi masalalarni ham samarali hal etish bilan birga, jamiyat hayotidagi muammoli masalalar yechimiga ham sezilarli ta’sir o‘tkazadigan yangi, jozibali tomonlarini ko‘rsatmoqda. Shu bois, mamlakatni ijtimoiy-iqtisodiy taraqqiy ettirishning asosiy omillaridan hisoblangan turizmni rivojlantirish dolzarb vazifalardan bo‘lib qolayotgan ekan, bu sohani ilmiy nuqtai nazardan tahlil etish muhim ahamiyatga ega hisoblanadi.

### **Metodlar va o‘rganilganlik darajasi:**

O‘zbekistonda so‘nggi yillarda turizm sohasini rivojlantirishga katta e’tibor qaratilmoqda. Turizmning turli yo‘nalishlari, ayniqsa ichki va ziyorat turizmi salohiyatini yanada oshirish orqali turistik oqimni ko‘paytirish muhim ahamiyat kasb etmoqda. Xususan, 2023-yilda qabul qilingan “O‘zbekiston – 2030” strategiyasining 58-bandi “O‘zbekistonda tashqi va ichki turizmni rivojlantirish uchun keng sharoitlar yaratish orqali sayyohlar sonini oshirish” deb belgilangan bo‘lib, undagi asosiy chora-tadbirlardan biri esa xorijiy turistlar sonini 15 mln.ga, ichki sayyohlar sonini 25 mln.ga, ziyorat turizmi bo‘yicha keladigan turistlar sonini 3 mln. nafarga oshirishdan iborat[3].

Turizm sohasini rivojlantirishda xorijiy investisiyalarni jalb etish muhim ahamiyat kasb etadi. Hozirgi kunda dunyo bo‘ylab eng ko‘p turist jalb qiluvchi davlatlar

tajribasi shuni ko'rsatmoqdaki, xususiy sektorning faol ishtiroki, xorijiy kapital bilan amalga oshirilayotgan investisiya loyihalari turizm infratuzilmasini sifat jihatdan yangi bosqichga olib chiqadi.

O'zbekiston Respublikasi Prezidenti Sh.Mirziyoyev turizmning iqtisodiyotdagi ulushini 7 foizga, eksportni 10 mlrd. dollarga yetkazish bo'yicha 2040 yilgacha strategiya ishlab chiqilayotganini ta'kidladi. Zamonaviy turizm marshrutlarini tashkil etish bo'yicha muhim vazifalarni belgilab berdi.

Turizm qo'mitasi hokimliklar bilan birgalikda respublikadagi 36 ta tuman va shaharni etno, gastronomik, tibbiy, ekstremal, madaniy-tarixiy, ziyorat, qishki va agroturizm asosida rivojlantirish bo'yicha katta dastur tasdiqlaydigan bo'ldi. Mutasaddilar oldiga ruxsatnomani sayyohlik marshrutiga Yagona interaktiv portal orqali 10 kunda berishni joriy qilish vazifasi qo'yildi[7].

**Muhokama.** Barchaga ma'lumki, bir necha yillar davomida butun dunyoda turizm sohasi rivojlanib kelmoqda. Har bir davlatning ichki va tashqi iqtisodiyotini mana shu turizm sohasi yuksak darajalarga olib chiqmoqda. Har bir davlat o'z kelajagi va rivoji uchun ushbu sohaga sarmoya, ya'ni investisiya kiritmoqda. Sarmoya kiritilmagan ish hech qachon rivojlanmaydi, u ishda yuksaklik bo'lmaydi[5.41].

Turizmning tarixi va rivojlanish davrlari haqida gapiriladigan bo'lsa, turizmning tarixi XIX asr boshlariga borib taqaladi. Dastlab Angliyadan Fransiyaga uyushgan sayyohlik tashkil etilgan (1815), turizmning asoschisi hisoblanmish ingliz ruhoniysi Tomas Kuk 1843-yilda 1-temir yo'l sayyohligini tashkil qilgan. Shundan so'ng u o'zining xususiy turistik korxonasini tuzdi va 1866-yilda dastlabki sayyohlik guruhlarini AQSHga jo'natildi. Sharqda arab sayyohi Ibn Battuta 21 yoshida sayohatni boshlab, deyarli barcha Sharq va Shimoliy Afrika mamlakatlarini piyoda kechib chiqdi. Turizm sohasi O'zbekistonda ham iqtisodiyotning ajralmas bo'lagi hisoblanadi. Bu sohaga

kiritilgan sarmoya albatta, o‘z o‘rnini topadi va kelajak uchun mustahkam poydevor bo‘lib xizmat qiladi [4.43].

O‘zbekistonda turizmning uchta asosiy turi mavjud: kirish, chiqish va ichki turizm. Kirish va ichki turizmga asosiy va maxsus turistik mahsulotlar kiradi: turistik diqqatga sazovor joylarga ekskursiyalar; mehmonxonalar, dam olish maskanlari, kurortlar, sanatoriylar, sayyohlik qishloqlari, uy-lagerlar, lagerlarda joylashtirish; milliy taomlar va vinolarni tatib ko‘rish; festivallar va bayram tadbirlarida ishtirok etish; mamlakat bo‘ylab qulay harakatlar.

O‘zbekistonda sayohat va dam olishning barcha turlarini sport, etnik, yoshlar, ekologik, gastronomik, tibbiy, madaniy tadbir, ziyorat, adabiy, qishki, velosport va boshqa turizm turlariga bo‘lish mumkin, Ularning ayrimlari uchun mavsumiylik xos bo‘lib, yo‘nalishni tanlashda mana shu jihatlar e‘tiborga olinishi kerak. O‘zbekistonga kelgan sayyohlar o‘z maqsadlari va yil uchun rejalashtirilgan byudjetga muvofiq, yolg‘iz, do‘stlari yoki oilasi bilan yoki sayohatchilarni oldindan rejalashtirilgan marshrut bo‘ylab qiziqarli va hayajonli joylarga olib boradigan gid bilan sayohat qiladilar[8].

Yevroosiyo mintaqasida esa turizmning dastlabki ko‘rinishi Xitoydan O‘rta Yer dengizigacha cho‘zilgan Buyuk Ipak yo‘li Sharq va G‘arb o‘rtasida tovarlar va madaniyatlar almashinuvini osonlashtiradigan savdo yo‘llari tarmog‘i sifatida namoyon bo‘ldi. U birinchi navbatda savdo yo‘li bo‘lsa-da, sayohatchilar, savdogarlar, olimlar, diplomatlar orqali bir necha davlatlar, xalqlar bilan muloqot o‘rnatishiga va sivilizasiyalarning yaqinlashuviga hissa qo‘shdi. O‘rta asrlar davrida jamiyatdagi dinning ustunligi xalqaro ziyorat turizmining rivojlanishiga asos bo‘ldi. Muqaddas amallarni bajarish, gunohlardan poklanish va boshqa maqsadlarda muqaddas ziyoratgohlarga borish odat tusiga aylangan. Bunga yaqin Sharq, Arabiston, Hindiston,

Tibet hududlaridagi ziyoratgohlarni misol qilib keltirish mumkin. Buyuk geografik kashfiyotlar esa qit'alararo sayohatlarni amalga oshirish imkonini berdi[1].

Turizm davlatlarning ijtimoiy, madaniy va ta'lim sohalariga sezilarli ta'sir ko'rsatadi. Xalqaro aloqalarga hamda alohida shaxslar va butun jamiyatning orzu-umidlarini hurmat qilish va adolatga asoslangan tinchlikparvarlik doirasida, turizm insonlarning bir-birini o'rganishi va tushunishining ijobiy va doimiy omili, shuningdek, xalqlar o'rtasidagi hurmat va ishonchning yanada yuqori darajasiga erishishi uchun asos bo'lib xizmat qiladi[6.74].

### **Tadqiqot natijalari:**

Turist moddiy va ma'naviy turistik mahsulotlarning iste'molchisidir. Moddiy turistik mahsulotlar deyilganda - turistlarni joylashtirish, tashish, ovqatlantirish, maishiy xizmatlar ko'rsatish shoxobchalari, tarixiy va madaniy yodgorliklar va ularda ko'rsatiladigan barcha moddiy xizmatlar majmui tushuniladi. Ma'naviy turistik mahsulotlar deyilganda esa (masalan, tarixiy turizm bo'yicha) turistlarni tarixiy va madaniy yodgorliklar bilan tanishtirish maqsadida gid-ekskursovodlar tomonidan ularga berilgan tarixiy ma'lumotlar va axborotlar, (madaniy turizm bo'yicha) turistlarga festivallar, karnavallar, tomoshalar, konsyertlar, teatrlar, darbozlar, sirkalarda berilgan madaniy ozuqalar, ruhiy kechinmalar tushuniladi. Demak, turistlar mana shunday turistik mahsulotlarning iste'molchisidir[5.116].

Turli mamlakatlar turizmning qaysi turi ko'proq rivojlanganiga qarab u yoki bu toifaga kiritiladi, ular statistikada ko'rsatiladi yoki ko'rsatilmaydi. Masalan, Sankt-Peterburgda yirik port shahri sifatida dengiz safari turizmi muhim o'rin tutadi (dengiz turistlarining soni mavsum va mintaqadagi vaziyatga qarab 150-250 ming atrofida). Xalqaro turizmning barcha qonunlariga ko'ra, dengiz turistlari ekskursantlar toifasiga kiritilsa-da, ular turist sifatida hisobga olinadi va statistik hisobotda alohida bo'linga ajratiladi. Bir kunda 21 % rossiyalik turistlar Finlyandiyaga tovar xarid qilgani chegara

yaqinidagi savdo markazlariga tashrif buyuradilar. Vaqt ko'rsatkichlari bo'yicha ular mamlakatga bir necha soatga xaridor sifatida kirib kelgan ekskursantlardir[5.121].

O'zbekistonda ham turizm milliy iqtisodiyotning yetakchi tarmog'iga aylanishi uchun barcha shart-sharoitlar mavjud. Hozirgi kunda O'zbekistonda milliy turizm modeli rivojlanish bosqichida bo'lib, unda o'zbek xalqining mentaliteti – sharqona mehmondo'stlik va g'arb xizmat standartlarining uyg'unlashuviga erishishga asosiy e'tibor qaratilmoqda. Turizm sohasida yuz berayotgan tub ijtimoiy-iqtisodiy o'zgarishlar mazkur sohada bozor munosabatlariga asoslangan turizm modelini shakllantirishga yo'naltirilgan. Shunga qaramasdan hozirgi kunda mavjud imkoniyatlardan foydalanish darajasi ancha past. Respublikamizda mavjud 8 mingdan ortiq madaniy va tabiiy meros obyektlaridan atigi 5-8 foizidan turistik maqsadlarda foydalaniladi, xolos. O'zbekistonda xalqaro turizmni rivojlantirish, turistik salohiyatdan oqilona foydalanish mamlakat tashqi iqtisodiy faoliyatining rivojlanishiga, valyuta tushumining o'sishiga, eksport tarkibining takomillashuvi va diversifikatsiyalashuviga ijobiy ta'sir ko'rsatadi. Bu sohada Saudiya Arabistoni tajribasini umumlashtirish xalqaro turizmni quyidagi yo'nalishlarda rivojlantirish maqsadga muvofiq ekanligini ko'rsatadi: - turizm sohasida xalqaro aloqalarni kengaytirish va mustahkamlash, xalqaro turistik tashkilotlar bilan aloqalarni yo'lga qo'yish, turizm sohasiga xorijiy investitsiyalar va xalqaro kreditlarni jalb qilish bo'yicha keng chora-tadbirlar tizimini ishlab chiqish; - yangi mehmonxonalar, kempinglar, turbazalar, otellar, motellar qurish va mavjudlarini ta'mirlash hamda zamonaviylashtirish hisobiga turizmning xalqaro talablarga javob bera oladigan moddiy-texnika bazasi va zamonaviy xalqaro turizm infratuzilmasini barpo etish va ulardan samarali foydalanish; - aeroportlarda, temiryo'l vokzallarida, avtobus stansiyalarida xalqaro terminallar qurish, ularni ta'mirlash va kengaytirish, shuningdek, barcha turistlarni qabul qilish markazlarida zamonaviy kommunikatsiya tizimlarini barpo etish, - xalq amaliy san'ati, hunarmandchilik,

ustaxonalar, an'anaviy milliy buyumlar, suvenirlar va turistlar tomonidan talab yuqori bo'lgan mahsulotlar ishlab chiqarish bilan shug'ullanuvchilarni har tomonlama qo'llab-quvvatlash; - respublikamizning tabiiy, iqtisodiy va tarixiy salohiyatidan kelib chiqqan holda turizmning turli shakllari — ekskursiya va o'rganish turizmi, arxeologik turizm, rekreatsion turizm, sarguzasht turizmi, ekzotik turizm, ekologik turizm, konferens-turlar, diniy turizm, etnik va nostalgiya turizmini rivojlantirish; - turizm sohasini axborot bilan ta'minlash va turistik biznesda eng yangi texnologiyalardan foydalanish asosida respublikamizning turistik imkoniyatlari to'g'risidagi ma'lumotlarni internet saytlari orqali xorijiy mamlakatlarga tarqatishdir. va boshqalar.[9.110.]

#### **Xulosa:**

O'zbekiston mustaqillikka erishgach, turizm sohasini milliy iqtisodiyotning ustuvor yo'nalishlaridan biri sifatida rivojlantirishga katta e'tibor qaratildi. So'nggi yillarda turistik vizalar soddalashtirildi, yangi yo'nalishlar rivojlantirildi, infratuzilmaviy loyihalar amalga oshirildi va xorijiy investitsiyalar jalb qilindi. Kelajakda turizmni raqamlashtirish, xizmat sifatini xalqaro standartlarga moslashtirish va ichki turizmni rivojlantirish asosiy vazifalardan hisoblanadi. Turizm yangi ish o'rinlarini yaratish, yoshlarni jalb qilish va barqaror rivojlanishni ta'minlashda muhim rol o'ynaydi hamda O'zbekistonning xalqaro turistik mavqeini mustahkamlashga xizmat qiladi.

#### **Iqtiboslar/Сноски/References:**

1. Alimov Sh. O'ZBEKISTONDA TURIZMNI RIVOJLANTIRISHNING JAHON TAJRIBASI MUAMMO VA ISTIQBOLLAR. Proceedings of International Conference on Educational Discoveries and Humanities. Hosted online from Plano, Texas, USA. Date: 1 st February, 2023, ISSN: 2835-3196, B. 142

2. ABABAXRIYEVA O. TURIZM SOHASINING PAYDO BO'LISH TARIXI VA MAMLAKAT IQTISODIY RIVOJLANISHIDA TURIZM

INDUSTRIYASINING O‘RNI. International Islamic Academy of Uzbekistan Volume 5 | IIAU Conference 5 | 2024 Turkiy xalqlar madaniyati, falsafasi, aloqalari: tarix, bugun va kelajak. B. 420

3. Astanakulov O. O‘ZBEKISTONDA ZIYORAT TURIZMINI RIVOJLANTIRISHDA XALQARO TAJRIBADAN FOYDALANISH: MALAYZIYA MISOLIDA. Scientific Journal of “International Finance & Accounting” Issue 6, December 2023. ISSN: 2181-1016

4. Madrimova A.Saydullayeva.O.TURIZM SOHASINING TARIXI VA UNING RIVOJLANISH DAVRLARI. YURTIMIZNING TARIXIY MANZILGOHLARI.Research Focus, Uzbekistan. | VOLUME 2 | 2023 ISSN: 2181-3833 ResearchBip (14) | Google Scholar | SJIF (5.708) | UIF (8.3), B.43

5. Mirzayev, Murotjon Ahmadjonovich. Turizm asoslari: bakalavriat ta'lim YO'nalishlari talabalari uchun o'quv qo'llanma/ M.A Mirzayev, M.T. Aliyeva; mas'ul muharrir ASh. Bekmurodov; O'zbekiston Respublikasi Oliy va o'rta maxsus ta'lim vazirligi. - T.: O'zbekiston faylasuflari milliy jamiyati nashriyoti, 2011. - 288 b.

6. [parliament.gov.uz/en/news/turizm-rivoji-taraqqiyotning-muhim-omili](http://parliament.gov.uz/en/news/turizm-rivoji-taraqqiyotning-muhim-omili)

7. [https://gov.uz/oz/pages/tourism\\_type](https://gov.uz/oz/pages/tourism_type)

8. T.N. Shovdirov. O‘ZBEKISTONDA TURIZMNI RIVOJLANTIRISHNING JAHON TAJRIBASI MUAMMO VA ISTIQBOLLAR. Builders of The Future ISSN: 2181-2705. B.110

## **Development of Digital Banking in Uzbekistan Over the Past Five Years**

*Tashkent State University of Economics*

*Assistant of the Department of General Economic Disciplines*

*Sherali Alisherovich Akbarov*

### **Abstract**

This article provides a comprehensive analysis of the development of digital banking in the Republic of Uzbekistan during the period from 2019 to 2024. The study covers the key stages of digital transformation in the banking sector, including regulatory and legal reforms, the implementation of innovative technologies, and changes in consumer behavior. The research findings may be used by regulatory authorities, commercial banks, and FinTech companies to develop strategies for advancing digital financial services.

**Keywords:** digital banking, fintech, electronic payments, mobile banking, financial technologies, digital transformation, cashless payments, financial inclusion, regulatory framework, banking sector of Uzbekistan.

### **Введение**

За последние пять лет банковский сектор Узбекистана претерпел значительную трансформацию, обусловленную глобальными трендами цифровизации и национальной политикой модернизации финансовой системы. После 2016 года в стране начались масштабные экономические реформы, создавшие благоприятные условия для внедрения инновационных финансовых технологий. Актуальность исследования развития цифрового банкинга в Узбекистане обусловлена необходимостью систематизации накопленного опыта, оценки эффективности реализованных мер и определения перспективных направлений дальнейшего развития.

## Методология

Для достижения поставленных целей и задач в исследовании применялась комбинированная методология, включающая количественные и качественные методы сбора и анализа данных.

Дизайн исследования: Смешанный (mixed methods), сочетающий анализ количественных данных и качественную оценку экспертных мнений.

Методы сбора данных:

1. Анализ вторичных данных: Систематизация и анализ официальной статистики Центрального банка Республики Узбекистан, Государственного комитета по статистике, Министерства цифровых технологий, а также отчетов международных организаций (Всемирный банк, МВФ, АБР).
2. Контент-анализ нормативных документов: Изучение законов, постановлений, нормативных актов и стратегических документов, регулирующих сферу цифрового банкинга и FinTech.
3. Анализ данных компаний: Исследование публичных отчетов и годовых пресс-релизов ведущих банков (НБУ, "Капиталбанк", "Ипотекабанк", "Алокабанк") и FinTech-компаний (Payme, Click, Uzum Bank).

Методы анализа данных:

1. Сравнительный анализ: Сравнение динамики ключевых показателей по годам и с другими странами региона (Казахстан, Азербайджан).
2. Трендовый анализ: Выявление основных тенденций развития на основе временных рядов статистических данных.
3. Контент-анализ: Качественный анализ текстов нормативных документов и экспертных интервью.
4. SWOT-анализ: Оценка сильных и слабых сторон, возможностей и угроз развития цифрового банкинга в Узбекистане.

Период исследования: 2019-2024 годы (с выделением ключевых этапов развития).

Ограничения исследования: Основным ограничением является неполнота некоторых статистических данных за ранний период (2019-2020 годы), а также

динамичность развития сектора, что требует постоянного обновления информации.

### **Результаты и обсуждение**

Нормативно-правовая эволюция и институциональные изменения

За исследуемый период в Узбекистане сформировалась комплексная нормативная база для развития цифрового банкинга. Ключевыми нормативными актами стали:

- Указ Президента № УП-5548 от 03.10.2018 "О мерах по коренному совершенствованию деятельности Центрального банка Республики Узбекистан", заложивший основы современной финансовой системы.
- Постановление Президента № ПП-4312 от 05.07.2019 "О мерах по дальнейшему развитию и повышению конкурентоспособности финансового рынка", предусматривавшее создание условий для развития FinTech.

Примечание: данные за 2024 год представлены по состоянию на октябрь 2024 года, экстраполяция на конец года.

1. Мобильный банкинг как доминирующий канал: К 2024 году более 85% цифровых банковских операций совершаются через мобильные приложения. Лидерами по количеству пользователей мобильных приложений стали "Капиталбанк" (5.2 млн), НБУ (4.8 млн) и "Ипотекабанк" (3.7 млн).
2. Рост FinTech-сектора: На рынке сформировались сильные независимые FinTech-компании:
  - Raume (запущен в 2019 году) - более 8 млн пользователей, экосистема платежей и микрокредитов.
  - Click (основан в 2018 году) - более 6.5 млн пользователей, фокус на платежах и переводах.
  - Uzum Bank (первый необанк, запущен в 2023 году) - более 2 млн пользователей за первый год работы.
3. Внедрение Open Banking: С 2022 года ЦБ РУз инициировал поэтапное внедрение принципов Open Banking. К 2024 году 15 банков предоставляли открытые API для третьих сторон, что позволило создавать интегрированные финансовые сервисы.
4. Развитие систем быстрых платежей: В 2021 году была запущена национальная система быстрых платежей "UzCard Instant", позволяющая осуществлять

переводы между картами разных банков в режиме реального времени. К 2024 году через систему ежедневно проходит более 500 тыс. операций.

### **Выводы**

Проведенное исследование позволяет сделать следующие выводы:

За период 2019-2024 годов цифровой банкинг в Узбекистане прошел путь от зарождающегося сегмента до основного канала предоставления банковских услуг. Количественные показатели (охват пользователей, доля безналичных платежей, объем операций) демонстрируют устойчивый экспоненциальный рост. Основными драйверами развития стали: последовательная государственная политика поддержки цифровизации, рост интернет- и смартфон-проникновения, активность частного сектора (как банков, так и независимых FinTech-компаний), а также изменение потребительских предпочтений, ускоренное пандемией COVID-19.

### **Список использованной литературы**

1. Центральный банк Республики Узбекистан. (2020-2024). Годовые отчеты о развитии банковской системы. Ташкент: ЦБ РУз.
2. Центральный банк Республики Узбекистан. (2021). Концепция развития цифрового банкинга в Республике Узбекистан на 2021-2023 годы. Ташкент: ЦБ РУз.
3. Министерство цифровых технологий Республики Узбекистан. (2023). Отчет о развитии IT-сектора и цифровизации в Узбекистане. Ташкент.
4. Государственный комитет по статистике Республики Узбекистан. (2024). Цифровая экономика Узбекистана: статистический сборник. Ташкент.
5. Всемирный банк. (2023). Uzbekistan Digital Economy Assessment. Washington, DC: World Bank Group.
6. Азиатский банк развития. (2022). Promoting Digital Finance in Central Asia. Manila: Asian Development Bank.
7. PwC Uzbekistan. (2024). FinTech and Digital Banking Survey 2024: Uzbekistan Perspective. Ташкент: PwC.

**ARUZ AND ARTISTIC EXPRESSION: ON THE EXAMPLE OF SAYFI  
SARAYI'S POETRY**

**Qodirova Barno,**

docent, doctor of Philosophy in Philology (PhD),

Samarkand State University

Samarkand, Uzbekistan

[kodirova.b86@gmail.com](mailto:kodirova.b86@gmail.com)

**Abstract.** *This article analyzes the use of the aruz poetic meter, one of the main systems of classical Eastern poetry, in the works of Sayfi Sarayi. The study focuses on the poet's use of the hazaj, ramal, and rajaz meters, as well as their musaddas and musamman forms, illustrated with textual examples. The structure of aruz feet, the arrangement of syllables, and the musical and artistic potential of these meters are examined. The research demonstrates Sayfi Sarayi's adherence to the classical aruz tradition and highlights the high artistic mastery of his poetry.*

**Keywords:** aruz meter, Sayfi Sarayi, hazaj meter, ramal meter, rajaz meter, classical poetry, poetic feet, syllable structure, musaddas, musamman.

**ARUZ VA BADIYY IFODA: SAYFI SAROYI SHE'RIYATI MISOLIDA**

**Qodirova Barno,**

dotsent, filologiya fanlari bo'yicha falsafa doktori (PhD),

Samarqand davlat universiteti

Samarqand, O'zbekiston

[kodirova.b86@gmail.com](mailto:kodirova.b86@gmail.com)

**Annotatsiya.** Mazkur maqolada Sharq mumtoz she'riyatining asosiy poetik tizimlaridan biri bo'lgan aruz vaznining Sayfi Saroyi ijodidagi qo'llanish xususiyatlari tahlil qilinadi. Shoir she'riyatida asosan hazaj, ramal va rajaz bahrlarining ishlatilishi, ularning musaddas va musamman ko'rinishlari misollar asosida yoritiladi. Aruz ruknlarining

tuzilishi, hijolarning tartibi hamda vaznlarning musiqiyliigi va badiiy ifoda imkoniyatlari ochib beriladi. Tadqiqot natijalari Sayfi Saroyi she'riyatining aruz an'alariga sodiqligi va uning badiiy mahorati yuqori darajada ekanini ko'rsatadi.

**Kalit so'zlar:** aruz vazni, Sayfi Saroyi, hazaj bahri, ramal bahri, rajaz bahri, mumtoz she'riyat, rukn, hijolar, musaddas, musamman.

**АРУЗ И ХУДОЖЕСТВЕННАЯ ВЫРАЗИТЕЛЬНОСТЬ:  
НА МАТЕРИАЛЕ ПОЭЗИИ САЙФИ САРАИ**

**Кодирова Барно,**

доцент, доктор философии по филологии (PhD),

Самаркандский государственный университет

Самарканд, Узбекистан

[kodirova.b86@gmail.com](mailto:kodirova.b86@gmail.com)

**Аннотация.** *В данной статье рассматриваются особенности использования арузной системы стихосложения в поэзии Сайфи Сараи. Основное внимание уделяется анализу бахров хазадж, рамал и раджаз, а также их форм мусаддас и мусамман на основе поэтических примеров. Раскрываются структура арузных стоп, порядок чередования слогов, их музыкальность и художественно-выразительные возможности. Результаты исследования показывают приверженность поэта классическим традициям аруза и высокий уровень его художественного мастерства.*

**Ключевые слова:** аруз, Сайфи Сараи, бахр хазадж, бахр рамал, бахр раджаз, классическая поэзия, стопа, слог, мусаддас, мусамман.

**Kirish.**

Sharq mumtoz adabiyotida keng qo'llanib kelgan aruz vazni she'r misralarida qisqa va cho'ziq hijolarning muayyan tartibda guruhlanib takrorlanishiga asoslanadi. Sayfi Saroyi

she'riyati ham bevosita sharq mumtoz adabiyotining an'anasi hisoblangan ana shu aruz vaznida yozilgan.

Shoir she'riyatida asosan aruz vaznining hazaj, ramal, rajaz bahrlari ko'p uchraydi.

Aruz sistemasidan bizga ma'lumki, hazaj bahri mafoiylun ruknining she'r misralarida takrorlanishiga asoslanadi. Shu asl rukn va uning furu'lari hazaj bahrining ko'pgina vaznlarini belgilash imkoniyatini yaratadi.<sup>1</sup>

Adabiyotimizda hazaj bahrining musaddas (olti ruknli), musamman (sakkiz ruknli), hamda mustahzod (ortirilgan, 12 ruknli) vaznlari ko'p qo'llanilgan. Sayfi Saroyi she'riyatida esa hazaj bahrining faqatgina musaddas va musamman vaznlari ishlatilgan.

1. Hazaji musaddasi mahzuf:

Kimi to'ti bekin chaynar shakarni,

Kimi lafzi bilan o'rtar dararni.<sup>2</sup>

V - - - V - - - V - -

ma-fo-iy-lun ma-fo-iy-lun fa-uv-lun.

Demak, baytning sadr, ibtido', hashvlari – Solim, aruz va zarb esa mahzuf rukniga teng. Shunga ko'ra, uning vazni hazaji musaddasi mahzuf deb ko'rsatilgan.

Kimining so'zlari mavzunu shirin,

Kimining

loyiqi tashrifu tahsin.<sup>3</sup>

V - - - V - - - V - -

ma-fo-iy-lun ma-fo-iy-lun fa-uv-lun.

Bunga yana misollar keltiramiz:

Yangi oyduz qoshing, ey ko'rkaboyim,

Qilur bayram yuzungni ko'rsa soim.

<sup>1</sup> Qarang. To'ychiev U. O'zbek poeziyasida aruz sistemasi. – Toshkent: Fan, 1985.

<sup>2</sup> O'zbek adabiyoti. V tom, birinchi kitob, – Toshkent: Badiiy adabiyot nashriyoti, 1966. – B. 22.

<sup>3</sup> O'zbek adabiyoti. V tom, birinchi kitob, – Toshkent: Badiiy adabiyot nashriyoti, 1966. – B. 22.

<sup>2</sup> Sayfi Saroyi. She'rlar. Guliston. – Toshkent: G'afur G'ulom nomidagi badiiy adabiyot nashriyoti, 1968. – B. 32.

Kerak o'ltur, kerak asra, qulingman,  
Muborak buyrug'ungdur qutlu royim.<sup>2</sup>

2. Hazaji musaddasi maqsur:

Jahon shoirlari, ey gulshani bog',  
Kimi bulbul durur so'zda, kimi zog'.

(O'sha asar 22-bet)

V- - - V- - - V- ~

Ma-fo-iy-lun ma-fo-iy-lun ma-fo-iy-l

Bu vaznda baytlardagi olti ruknning ikkitasi misralar oxiridagi aruz va zarb ruknlari mafoiylun ruknining maqsur ko'rinishida mafoiyl shaklida bo'ladi. Yuqoridagi vazndan farqi, oxirgi ruknlar o'ta cho'zuq hijo bilan tugallanadi.

3. Hazaji musaddasi ashtar:

Qurub qoshi yosin qaro ko'zlaring,

Otar

kirpik o'qin menga ko'zlaring.

(S.Saroyi 30-bet)

V- - - V- - - -V-

Ma-fo-iy-lun ma-fo-iy-lun fo'-i-lun.

4. Hazaji musammani solim:

Meningtek nechalar hayron o'shul jodu qaroqing'a,

Ko'rub jismin hijolagdan ravon bo'ldi qaro qing'a.

(S.Saroyi 26-bet)

V- - - V- - - V- - - V- - -

Ma-fo-iy-lun ma-fo-iy-lun ma-fo-iy-lun ma-fo-iy-lun.

Bu vazn she'riyatimizdagi eng yoqimli o'lchovlardan biri sanaladi. To'rtta qisqa hamda 12 ta cho'ziq hijoning bu xildagi mutanosib takrori jozibali va musiqali ohangni

vujudga keltiradi. Adabiyotshunos Anvar Hojiahmedov bu haqida fikr yuritar ekan «mazkur o‘lchovni dastlab Atoiy, Sakkokiy, Lutfiy, Gadoiy, Hofiz Xorazmiy lirikasida»<sup>4</sup> uchrashini aytadi. Bizningcha bu vaznni dastlabki namunasi Sayfi Saroyi she’riyatida qo‘llangan:

Jamolin ko‘rmaga hasrat bo‘lib andan murodim

Qurub ilgaymu teb bir kez qo‘lun sulton qaroqing‘a.

(S.Saroyi 26-bet)

V- - - V- - - V- - - V- - -

Ma-fo-iy-lun ma-fo-iy-lun ma-fo-iy-lun ma-fo-iy-lun.

Mufarrih shevali dilbar, tili so‘zi shakkar,

Kiyik ko‘zli, qamar manzar, malohat mulki sultoni.

(S.Saroyi 14-bet)

V- - - V- - - V- - - V- - -

Ma-fo-iy-lun ma-fo-iy-lun ma-fo-iy-lun ma-fo-iy-lun.

Shakardan totlidur xulqung, karamda xotiring matlab,

matlab, matlabi ma‘dan, na ma‘da, ma‘dani javhar.

bet)

Na

(S.Saroyi 23-

V- - - V- - -

V- - - V- - -

Ma-fo-iy-lun ma-fo-iy-lun ma-fo-iy-lun ma-fo-iy-lun.

Sayfi Saroyi she’riyatida yana o‘zbek mumtoz she’riyatida eng ko‘p qo‘llanilgan ramal bahridagi she’lar ham ko‘p uchraydi:

Ramali musaddasi mahzuf:

Ul yuzi oykim, jahonning jonidur,

Bu zamona xublarining xonidur.

<sup>4</sup> Hojiahmedov A. Mumtoz badiyat malohati. – Toshkent: Sharq, 1999. – B. 137.

(S.Saroyi 12-bet)

- V - - - V - - - V -

Fo-i-la-tun fo-i-lo-tun fo-i-lun.

Ramali musammani mahzuf:

Bu falak nechun meni doim qara qinda tutar,

Bu o'tim sayf o'ldurg'uchunmi qara qinda tutar.

(S.Saroyi 12-bet)

- V - - - V - - - V - - - V -

Fo-i-lo-tun fo-i-lo-tun fo-i-lo-tun fo-i-lun.

Bu baytdagi olti rukn sad rva ibtido', hashv ruknlari solim, ya'ni ularda foilotun rukni o'zgarishsiz takrorlanyapti. Har qaysi misra oxiridagi ruknlar esa foilunga tengdir.

Misol:

Dilbarimning zulfi sunbul, chehrasi gulzor erur,

Bo'yina

oshiq sanavbar, yuzina gulzor erur.

(S.Saroyi 12-bet)

- V - - - V - - - V - - - V -

Fo-i-lo-tun fo-i-lo-tun fo-i-lo-tun fo-i-lun.

Shunga alohida e'tibor berish lozimki, ramali musammani mahzuf vazni o'zbek mumtoz adabiyotida eng sevimli vazn hisoblangan. Buning sababi mazkur vaznning o'ynoqiligi, jozibadorligida, insonning rang-barang ichki kechinmalarini ifodaolash uchun qulayligidadir. Sayfi Saroyi she'riyatida ham sakkiz ruknli ramal bahridagi she'rlarning barchasini manna shu vazn, ya'ni ramali musammani mahzuf vazni tashlil qiladi.

Shoir she'riyatida rajaz bahri vaznlarini ham uchratish mumkin:

Oltun qanotin ochti esa subh shunqari,

Ko'k

ko'lga botti jumla kavokib kabutari.

(S.Saroyi 20-bet)

-- V - -- V - -- V - V -

Mustaf'ilun mustaf'ilun mustaf'ilun fa'ul.

Bu bayt rajazi musammani maxbuni axazz vaznida yozilgan.

Yoki:

Ey ko'rklilar xayoli bilan muftalo ko'ngul,

Ko'zi

bilan keturgan o'zina balo, ko'ngul.

(S.Saroyi 20-bet)

-- V - -- V - -- V - V -

Mustaf'ilun mustaf'ilun mustaf'ilun fa'ul .

Rajaz <sup>5</sup> bahri aruzning asosiy o'lchov turlaridan biri bo'lib, uning asosini mustaf'ilun aslining aynan takrori tashkil etadi. Sayfi Saroyi she'riyatida esa bu bahrning yuqoridagi kabi ko'rinishlari mavjud.

Sayfi Saroyi she'rlarini bitar ekan, o'z davri an'analariga muvofiq aruz o'lchoviga asoslandi, xilma-xil musiqiy va jozibador vaznlar zamirida g'oyaviy va badiiy jihatdan barkamol qasida va g'azallar, ruboiy va qit'alar yaratdi. U bu asarlarini yaratishda hazaj, ramal va rajaz bahrlariga tayandi.

Sayfi Saroyi ijodi serqirra ijod sanaladi. Badiiy mahorati esa juda kuchlidir. Shuning uchun ham shoirning badiiy mahorati o'zidan keyingi davr adabiyoti uchun ijodiy maktab vazifasini o'tadi.

### Foydalanilgan adabiyotlar:

1. To'ychiev U. O'zbek poeziyasida aruz sistemasi. – Toshkent: Fan, 1985.
2. O'zbek adabiyoti. V tom, birinchi kitob, – Toshkent: Badiiy adabiyot nashriyoti, 1966.
3. O'zbek adabiyoti. V tom, birinchi kitob, – Toshkent: Badiiy adabiyot nashriyoti, 1966.

<sup>5</sup> «Rajaz» so'zi arabcha bo'lib, «tezlik», «iztirob» ma'nolarini anglatadi.



4. Sayfi Saroyi. She'rlar. Guliston. – Toshkent: G'afur G'ulom nomidagi badiiy adabiyot nashriyoti, 1968.
5. Hojiahmedov A. Mumtoz badiyat malohati. – Toshkent: Sharq, 1999.



## **COMPARATIVE STUDY OF ADJECTIVE DEGREES IN ENGLISH AND UZBEKISTAN**

**Dilobar Azimova**

Teacher, Department of World Languages, Kokand University

**Mamurova Vasila**

Student of Kokand University

**Annotation.** This article provides a comparative analysis of the degree category, which is the most important morphological and semantic feature of the adjective category in English and Uzbek. The study covers the means of expression of adjective degrees, the correlation of morphological and analytical methods, and the specificity of intensity levels in both languages. The degree of correspondence of synthetic (affixal) and analytical (more/most) models in English with morphological (-roq) and lexical (eng, juda) means in Uzbek is studied. Also, the English equivalents of reduplication (qip-qizil) and reduction forms in adjectives, which are characteristic of the Uzbek language, are analyzed. The results of the study serve for typological linguistics and translation theory.

**Keywords:** quality level, comparative analysis, morphological method, analytical method, intensity, gradonymy, English language, Uzbek language, typology.

## **INGLIZ VA O‘ZBEK TILLARIDA SIFAT DARAJALARINING QIYOSIY TADQIQI**

**Dilobar Azimova**

Qo‘qon universiteti Jahon tillari kafedراسi o‘qituvchisi

**Mamurova Vasila**

Qo‘qon universiteti talabasi

**Annotatsiya** Ushbu maqolada ingliz va o‘zbek tillaridagi sifat turkumining eng muhim morfologik-semantik xususiyati bo‘lgan daraja kategoriyasi qiyosiy tahlil qilinadi. Tadqiqotda har ikki tilda sifat darajalarining ifodalanish vositalari, morfologik va analitik usullarning o‘zaro nisbati hamda intensivlik darajalarining o‘ziga xosligi yoritilgan. Ingliz tilidagi sintetik (affiksial) va analitik (more/most) modellarning o‘zbek tilidagi morfologik (-roq) va leksik (eng, juda) vositalar bilan muvofiqlik darajasi o‘rganiladi. Shuningdek, o‘zbek tiliga xos bo‘lgan reduplikatsiya (qip-qizil) va sifatlardagi kamaytirish shakllarining ingliz tilidagi ekvivalentlari tahlil qilinadi. Tadqiqot natijalari tipologik tilshunoslik va tarjima nazariyasi uchun xizmat qiladi.

**Kalit so‘zlar:** sifat darajasi, qiyosiy tahlil, morfologik usul, analitik usul, intensivlik, gradonimiya, ingliz tili, o‘zbek tili, tipologiya.

Sifat turkumi har qanday tilda predmet yoki hodisalarning belgi-xususiyatini, rang-tusini, shakli va hajmini ifodalovchi asosiy leksik-grammatik guruhlardan biri hisoblanadi. Ingliz va o‘zbek tillari turli til oilalariga (hind-yevropa va turkiy tillar) mansub bo‘lishiga qaramay, ularda sifat darajasi kategoriyasi muloqotda subyektning ob‘ektga bo‘lgan munosabatini va belgi miqdorini ko‘rsatishda markaziy o‘rin tutadi. Sifat darajalarining qiyosiy tadqiqi nafaqat sof lingvistik qiziqish uyg‘otadi, balki ikki til o‘rtasidagi konseptual tafovutlarni tushunishga ham yordam beradi. Har ikkala tilda belgi darajalari an’anaviy ravishda uchta: oddiy (positive), qiyosiy (comparative) va orttirma (superlative) darajalar sifatida tasniflanadi, biroq bu darajalarni shakllantirishda tillarning grammatik qurilishidan kelib chiquvchi sezilarli farqlar mavjuddir.

Ingliz tilida sifat darajalarini hosil qilish tizimi asosan sifatning bo‘g‘in tuzilishiga tayanadi. Bir bo‘g‘inli va ba’zi ikki bo‘g‘inli sifatlar sintetik usulda, ya’ni *-er* va *-est* suffikslari yordamida o‘zgaradi. Masalan, *small – smaller – the smallest* zanjiri o‘zbek tilidagi *kichik – kichikroq – eng kichik* shakliga to‘g‘ridan-to‘g‘ri muvofiq keladi. Biroq, ingliz tili ko‘p bo‘g‘inli sifatlarda analitik usulga o‘tadi, ya’ni daraja yasash uchun *more*

va *most* soʻzlaridan foydalaniladi (*more beautiful, the most beautiful*). Oʻzbek tilida esa tizim biroz boshqacha va barqarorroqdir. Oʻzbek tilshunosligida sifat darajalari asosan morfologik usulda (-roq) va leksik-sintaktik usulda (eng, juda, nihoyatda) ifodalanadi. Oʻzbek tilidagi *-roq* affiksi ingliz tilidagi *-er* va *more* vositalarining har ikkisini ham qoplashga qodir. Bu oʻrinda ingliz tilidagi analitiklik va oʻzbek tilidagi agglutinatv xususiyat oʻrtasidagi ziddiyat koʻzga tashlanadi.

Tadqiqotlar shuni koʻrsatadiki, oʻzbek tilida sifat darajalari tizimi faqat uchta daraja bilan cheklanib qolmaydi. Oʻzbek tilshunosligida sifatlarning kuchaytirish va kamaytirish shakllari alohida tadqiq etiladi. Masalan, intensivlikni ifodalashda oʻzbek tilida prefiksial xarakterga ega boʻlgan reduplikatsiya (takrorlash) usuli nihoyatda faoldir. *Qip-qizil, qop-qora, yam-yashil* kabi soʻzlar ingliz tilida morfologik jihatdan bunday qolipga ega emas. Ingliz tili bunday holatlarda leksik kuchaytirgichlarga murojaat qiladi: *bright red, pitch black, vivid green*. Bu holat oʻzbek tilining tasviriy imkoniyatlari rang va belgi intensivligini ifodalashda naqadar boy ekanligini koʻrsatadi. Shu bilan birga, oʻzbek tilidagi *-imtir, -ish, -simon* kabi affikslar orqali hosil qilinadigan belgi sustligi (kamlik darajasi) ingliz tilida asosan *-ish* suffiksi (*yellowish*) yoki *slightly, a bit* kabi ravishlar yordamida beriladi.

Gradonimiya masalasi, yaʼni belgining oʻsib borish tartibi har ikki tilda semantik qatorlarni hosil qiladi. Masalan, "sovuq" tushunchasini olaylik: oʻzbek tilida *iliq – iliqqina – sovuq – muzdek – juda muz* qatori mavjud boʻlsa, ingliz tilida *warm – cool – cold – freezing – icy* kabi leksik birliklar darajalanishni hosil qiladi. Bu yerda farq shundaki, oʻzbek tilida koʻp hollarda bitta oʻzakka turli affikslarni qoʻshish orqali daraja oʻzgarishi mumkin, ingliz tilida esa darajalanish koʻpincha leksik differensiyalashgan soʻzlar hisobiga amalga oshadi. Rang bildiruvchi sifatlar qiyoslanganda ham shunday holat kuzatiladi; oʻzbek tili rang intensivligini morfologik takrorlar bilan (oppoq)

ifodalasa, ingliz tili "snow-white" kabi kompozitlar (qo'shma so'zlar) yoki "pure white" kabi analitik birikmalardan foydalanadi.

Sifat darajalari tizimida artikllarning o'rni ham ingliz tilining o'ziga xosligini belgilaydi. Orttirma darajadagi sifatlar har doim *the* aniq artikli bilan qo'llanilishi shart bo'lsa, o'zbek tilida bu vazifani "eng" ko'makchisi va gapdagi tartib bajaradi. O'zbek tilida "eng" so'zi daraja yasashning eng yuqori nuqtasi hisoblanib, u sifatning barcha turlariga (bo'g'in sonidan qat'i nazar) birdek qo'llaniladi. Ingliz tilida esa *the most* va *-est* o'rtasidagi tanlov qat'iy fonetik-morfologik qoidalarga bo'ysunadi. Bu esa o'zbekzabon o'quvchilar uchun ingliz tilini o'rganishda asosiy qiyinchiliklardan birini tug'diradi, chunki o'zbek tilidagi bir xillik (uniformity) ingliz tilidagi ikkilik (duality) bilan to'qnash keladi.

Sifatlarning semantik guruhleri (hajm, shakl, rang, xususiyat) har ikki tilda ham deyarli bir xil kategoriyalarni qamrab oladi. Biroq, qiyosiy darajadagi bog'lovchilarning ishlatilishi farq qiladi. Ingliz tilidagi *than* bog'lovchisi o'zbek tilidagi chiqish kelishigi (-dan) affiksiga funksional jihatdan mos keladi. Masalan: *He is taller than me – U mendan balandroq*. Bu yerda o'zbek tilidagi *-roq* affiksi ba'zan tushib qolishi ham mumkin (*U mendan baland*), lekin ingliz tilida daraja ko'rsatkichi (*-er*) tushib qolishi gapning grammatik xatosi hisoblanadi. Bu o'zbek tilida kontekst va kelishik tizimi daraja ma'nosini yuklashda yetakchi rol o'ynashini, ingliz tilida esa morfologik markirovka birlamchi ekanini isbotlaydi.

Xulosa qilib aytganda, ingliz va o'zbek tillarida sifat darajalari kategoriyasi umumiy semantik maqsadlarga xizmat qilsa-da, ularni ifodalash usullari tillarning strukturaviy tabiatiga mos ravishda farqlanadi. Ingliz tili analitik va sintetik usullarning sintezidan foydalansa, o'zbek tili ko'proq morfologik va leksik vositalarga tayanadi. Ayniqsa, o'zbek tilidagi rang va belgi intensivligini ifodalovchi reduplikatsiya usuli ingliz tilidagi analitik tavsiflarga qaraganda ixchamroq va emotsionalroqdir. Ushbu

farqlarni chuqur o‘rganish tarjima jarayonida stilistik rang-baranglikni saqlab qolish va tillarni o‘qitish metodikasini takomillashtirishda muhim ahamiyat kasb etadi. Har ikki tildagi sifat darajalarining tadqiqi tillarning o‘zaro boyishi va lisoniy manzaralarning qiyosiy tahlili uchun boy material beradi.

### Foydalanilgan adabiyotlar

1. Axmedov, I. (2024). COMPARATIVE ANALYSIS OF ADJECTIVES IN ENGLISH AND UZBEK LANGUAGES. *QO‘QON UNIVERSITETI XABARNOMASI*. <https://doi.org/10.54613/ku.v13i.1081>
2. Kenjayeva, U., Djumabayeva, J., & Nazarov, M. (2020). THE COMPARATIVE STUDY OF THE ADJECTIVES DENOTING COLOR IN ENGLISH AND UZBEK LANGUAGES. *Theoretical & Applied Science*, 82, 479-482. <https://doi.org/10.15863/tas.2020.02.82.78>
3. Rabbimkulovich, Y., Jurakulovich, Y., Tashtanovich, O., Nasimovich, H., & Togamurotovich, R. (2020). Comparative analysis of adjectives in English and Uzbek languages. *Middle European Scientific Bulletin*. <https://doi.org/10.47494/mesb.2020.6.109>
4. Shirin, K., & Ruzikulovna, N. (2023). COMPARATIVE TEACHING METHODS OF "ADJECTIVE DEGREES" IN THE KOREAN LANGUAGE CLASSES WITH UZBEK LANGUAGE. *International Journal Of Literature And Languages*. <https://doi.org/10.37547/ijll/volume03issue03-07>
5. Toraqulova, N. (2025). DEGREES OF COMPARISON OF ADJECTIVES IN ENGLISH AND UZBEK. *SPIRITUAL INTEGRATION OF TURKISH PEOPLES: LANGUAGE, LITERATURE, CULTURE*. <https://doi.org/10.52773/tsuull.conf.2025/jtrz6472>

## Clinical and Diagnostic Significance of Metabolic Dysfunction and Liver Fibrosis Stages in Patients with Non-Alcoholic Fatty Liver Disease (NAFLD)

**Author:** Isroilov Muhammadali

Scientific Supervisor: Soliyev Alisher Qodirovich, PhD

### Abstract

**Background:** Non-alcoholic fatty liver disease (NAFLD) is a leading cause of chronic liver disease worldwide.

**Methods:** A prospective study of 84 patients was conducted to evaluate the link between metabolic markers and fibrosis. Liver stiffness was measured using transient elastography (FibroScan).

**Results:** A significant correlation was found between HOMA-IR and fibrosis stage ( $r=0.58$ ,  $p<0.05$ ). Patients with BMI  $>30$  kg/m<sup>2</sup> showed a 2.4-fold higher risk of advanced fibrosis (95% CI: 1.8–3.2).

**Conclusion:** Early metabolic intervention is crucial to prevent progression to cirrhosis. [112 words]

**Keywords:** NAFLD, Hepatology, Liver Fibrosis, Insulin Resistance, Transient Elastography, HOMA-IR.

**1. Introduction.** NAFLD has become a global health priority, affecting approximately 25% of the adult population. In Uzbekistan, the rising prevalence of obesity and type 2 diabetes has led to an increase in NAFLD cases. The primary challenge in clinical hepatology is the early identification of patients at high risk for liver fibrosis, which is the most significant predictor of mortality.

### 2. Materials and Methods

Study Population: 84 patients (mean age  $46.2\pm 5.4$  years) diagnosed with NAFLD.

**Measurements:** Anthropometric data (BMI, waist circumference), biochemical tests (ALT, AST, Lipid profile), and Insulin Resistance (HOMA-IR).

**Imaging:** Liver stiffness measurement (LSM) was performed using FibroScan® 502 Touch.

**Statistical Analysis:** Data were analyzed using SPSS v.26. Continuous variables are expressed as Mean  $\pm$  SEM.  $p < 0.05$  was considered statistically significant.

### 3. Results

The study revealed that metabolic dysfunction significantly correlates with the severity of liver damage.

Table 1. Clinical and Metabolic Profile of Study Participants

Variable	NAFLD Group (n=84)	Control Group (n=30)	p-value
BMI (kg/m <sup>2</sup> )	31.4 $\pm$ 2.1	23.2 $\pm$ 1.4	< 0.01
HOMA-IR	4.8 $\pm$ 0.6	1.2 $\pm$ 0.2	< 0.01
ALT (U/L)	58.6 $\pm$ 4.2	18.4 $\pm$ 2.1	< 0.05
LSM (kPa)	7.4 $\pm$ 1.2	4.2 $\pm$ 0.5	< 0.05

### 4. Discussion

Our findings confirm that insulin resistance (HOMA-IR) is a major driver of fibrogenesis. Comparison with international cohorts shows that patients in our region often present with advanced steatosis even at lower BMI thresholds, suggesting genetic or dietary influences.

### 5. Conclusion

Metabolic screening and non-invasive elastography should be integrated into the standard care for NAFLD patients. This approach allows for the early detection of fibrosis and the implementation of targeted therapies to reduce the burden of liver-related complications.

#### Key References (Sample)

1. EASL-EASD-EASO. Clinical Practice Guidelines for the management of non-alcoholic fatty liver disease. *J Hepatol.* 2021.
2. Younossi ZM, et al. Global epidemiology of NAFLD. *Hepatology.* 2020.
3. Turdiev R.A., et al. Prevalence of metabolic syndrome in Uzbekistan. *Journal of Internal Medicine.* 2022.

## **The Influence of Slang on the Contemporary English Lexicon: A Sociolinguistic and Digital-Era Perspective**

**Sirojiddinova Iroda Baxodirovna**

**Kokand university of andijan branch English for philology and language teaching**

Email: [ibaxodirova28@gmail.com](mailto:ibaxodirova28@gmail.com)

### **Abstract**

This study explores the structural, sociolinguistic, and technological influence of slang on the contemporary English lexicon. Moving beyond traditional interpretations of slang as informal or peripheral vocabulary, the paper argues that slang functions as a central mechanism of lexical innovation in the digital era. By integrating classical sociolinguistic theory with digital communication research, this study introduces four conceptual frameworks: Algorithmic Sociolinguistics, Compressed Lexical Evolution, the Cyclical Legitimization Model, and Platform-Driven Semantic Acceleration. The analysis demonstrates that slang reshapes semantic boundaries, redistributes lexical authority, and accelerates linguistic change through algorithmically mediated diffusion. The findings suggest that contemporary English lexical development cannot be fully understood without recognizing slang as a structural and evolutionary force.

**Keywords:** slang, sociolinguistics, lexical innovation, digital discourse, algorithmic diffusion, language evolution

### **1. Introduction**

Language is not a static system but a dynamic social organism. It adapts continuously to technological innovation, cultural transformation, and shifting social hierarchies. In the twenty-first century, one of the most visible mechanisms of lexical transformation in English is slang.

Historically, slang was associated with informal speech communities, youth groups, and marginalized populations. It was often perceived as unstable or linguistically inferior. However, contemporary evidence suggests that slang is not peripheral but central to lexical development.

The digital era has fundamentally altered the ecology of language. Social media platforms allow lexical innovations to circulate globally within hours. This

transformation challenges traditional sociolinguistic models of diffusion, which were based primarily on face-to-face interaction and gradual geographic spread.

This study argues that slang has evolved into a structural driver of lexical innovation. The research addresses the following questions:

1. How does slang contribute structurally to lexical change?
2. What mechanisms accelerate its diffusion in digital environments?
3. How do algorithms reshape sociolinguistic processes?
4. Under what conditions does slang become standardized?

The central thesis of this paper is that slang represents a democratized and accelerated form of lexical evolution shaped by digital mediation.

## **II. Historical Background of Slang and Lexical Evolution**

Slang has existed throughout the history of English. Many words currently regarded as standard once originated as informal expressions. The boundary between slang and standard language has always been fluid.

Language variation reflects social stratification and identity positioning according to sociolinguistic theory (Labov, 1972). Slang functions as a marker of solidarity within specific groups and differentiates insiders from outsiders.

The social bonding function of slang has been extensively documented in youth communities (Eble, 1996). It strengthens group identity and fosters linguistic creativity.

However, earlier diffusion models assumed localized communities. Lexical innovation spread gradually through social networks over extended periods. In contrast, contemporary slang diffuses through global digital infrastructures.

This shift necessitates theoretical expansion.

### **3. Theoretical Framework**

#### **3.1 Algorithmic Sociolinguistics**

Traditional sociolinguistic models explain language change through interpersonal networks. In the digital era, algorithms mediate visibility. Social media platforms

prioritize content based on engagement metrics. Slang expressions, due to their novelty and emotional intensity, often generate high engagement.

Thus, lexical diffusion is partially algorithm-driven. Algorithms function as non-human agents in language change. This perspective extends variationist sociolinguistics into digitally mediated environments.

### **Compressed Lexical Evolution**

Historically, lexical stabilization required decades. In digital culture, slang may move from innovation to dictionary inclusion within a few years.

Digital repetition increases exposure frequency. Increased exposure accelerates normalization. This phenomenon represents compressed linguistic time.

Compressed lexical evolution reflects the interaction between technological speed and linguistic adaptability.

### **Cyclical Legitimization Model**

Slang follows identifiable stages:

1. Innovation within a subculture
2. Viral diffusion
3. Mainstream adoption
4. Institutional recognition
5. Replacement by new innovation

This cyclical pattern ensures continuous lexical renewal. Once a slang term becomes mainstream, it often loses its exclusivity and is replaced by new forms.

### **Platform-Driven Semantic Acceleration**

Digital platforms influence communicative style. Short-form content encourages exaggeration and brevity. Meme culture promotes irony and semantic play. Comment-based interaction amplifies evaluative intensity.

These platform affordances accelerate semantic shift. Meaning evolves rapidly in response to digital communicative pressures.

This model connects technological design with semantic transformation.

#### **IV. Mechanisms of Slang-Based Lexical Innovation**

Slang contributes to lexical expansion through multiple linguistic processes:

##### **Semantic Shift**

Words acquire new evaluative meanings. Previously negative adjectives may gain positive connotations.

##### **Morphological Creativity**

Innovative suffixation and conversion generate new grammatical forms.

##### **Pragmatic Intensification**

Slang enhances expressive force and emotional density.

##### **Metaphorical Extension**

Concrete imagery becomes abstract social commentary.

These processes demonstrate structural consistency. Slang is not random; it follows identifiable linguistic patterns.

#### **V. Slang and Identity Construction (Extended Version)**

Language functions as a symbolic resource through which individuals construct, negotiate, and perform identity. Slang, in particular, serves as an indexical marker that signals social alignment, generational belonging, ideological stance, and cultural participation. Sociolinguistic theory has long emphasized that linguistic variation correlates with social differentiation and identity positioning Labov 1972.

In contemporary digital environments, identity is no longer performed solely in physical communities but within networked publics. Slang becomes a rapid signaling device. When a user adopts emerging lexical items, they implicitly demonstrate digital literacy and cultural awareness. This form of linguistic signaling operates as symbolic capital within online communities Bourdieu 1991.

A key transformation in the digital era is the speed at which identity markers circulate. Youth slang once remained confined to localized peer groups. Today, expressions spread globally through viral content, reshaping generational boundaries almost instantaneously. As a result, generational identity is no longer strictly age-based but participation-based. Individuals of different ages may align linguistically if they share digital cultural exposure.

Another crucial development is what can be termed **Performative Lexical Identity**. In digital discourse, identity is continuously curated. Slang operates not only as spontaneous speech but as strategic self-presentation. Users selectively employ slang to project humor, irony, intellectual distance, or social awareness. This strategic usage reflects style-shifting in online interaction Coupland 2007.

Moreover, slang contributes to micro-identity formation. Within broader digital communities, subgroups develop niche lexical repertoires. Gaming communities, fandom groups, cryptocurrency networks, and activist movements generate specialized slang. These lexical systems function as gatekeeping mechanisms, reinforcing in-group cohesion while limiting outsider participation.

The cyclical nature of slang also reflects identity renegotiation. Once an expression becomes mainstream, its symbolic exclusivity weakens. Early adopters often abandon such terms to maintain distinctiveness. This process supports the Cyclical Legitimization Model introduced earlier.

A further dimension involves emotional identity. Slang often carries intensified evaluative meaning. Such expressions allow speakers to amplify emotional stance. Digital communication, lacking prosodic cues, relies heavily on lexical intensity markers. Slang compensates for paralinguistic absence by encoding affect directly in vocabulary.

Thus, slang is not merely lexical creativity but a dynamic instrument of identity construction, social positioning, and symbolic boundary maintenance in digitally mediated society.

## **VI. Globalization and Hybridization (Extended Version)**

Globalization has fundamentally altered the sociolinguistic ecology of English. Digital communication collapses geographic distance, allowing slang to travel transnationally within hours. English functions simultaneously as a global lingua franca and as a recipient of cross-cultural lexical influence Crystal 2003.

This phenomenon leads to **Lexical Hybridization**. Slang increasingly incorporates elements from diverse linguistic backgrounds. Borrowings are not merely lexical imports but culturally recontextualized forms. When such expressions enter global English, they undergo semantic adaptation, phonological adjustment, and pragmatic reinterpretation.

Digital globalization differs from historical contact-based borrowing. Traditional borrowing required sustained community interaction. Contemporary borrowing may occur through viral media exposure alone. This process can be conceptualized as **Contact Without Proximity**. Cultural influence operates through algorithmic distribution rather than physical migration.

Hybridization also produces semantic layering. A single slang term may carry distinct meanings across communities while retaining shared core connotations. This multiplicity reflects what can be described as **Polycentric Meaning Formation**. Meaning authority is decentralized across global digital communities Androutsopoulos 2018.

However, globalization raises ethical considerations. When marginalized community slang becomes mainstream, questions of appropriation and power emerge. Lexical forms often originate within minority communities and later become commodified. This asymmetry reflects broader sociocultural hierarchies.

Additionally, globalization increases lexical competition. Multiple variants may circulate simultaneously. Algorithmic amplification determines which form achieves dominance. This dynamic reinforces the importance of Platform-Driven Semantic Acceleration.

Another new dimension is translanguaging. Digital users frequently blend English slang with elements of their native languages. This results in hybrid discourse forms that challenge rigid linguistic boundaries. English becomes a flexible matrix language rather than a fixed system.

Thus, globalization does not homogenize slang. Instead, it multiplies diversity while accelerating cross-cultural interaction.

## **VII. Lexical Authority and Democratization (Extended Version)**

Historically, lexical authority was institutional. Dictionaries, academies, and academic bodies determined linguistic legitimacy. In the digital era, lexical power has shifted toward distributed user communities.

Slang exemplifies this democratization. Frequency of usage across digital platforms often precedes lexicographic recognition. Institutional validation increasingly follows rather than dictates usage. This shift aligns with descriptive linguistic ideology.

A central concept here is **Crowdsourced Legitimacy**. When millions of users adopt a term, collective usage exerts normative pressure. Lexicographers track digital corpora to identify emerging patterns. Thus, institutional authority becomes reactive.

Algorithmic systems further redistribute lexical power. Visibility metrics determine which terms gain prominence. High-engagement expressions receive amplification, shaping collective awareness. This introduces a non-human dimension to lexical governance.

Another phenomenon is **Micro-Norm Formation**. Within specific platforms, localized norms emerge. A term may be standard within one platform yet marginal in another. Platform architecture influences lexical lifespan and stylistic expectations.

Commercialization also influences democratization. Brands and marketing agencies often adopt slang to appear culturally relevant. However, commercial usage may accelerate mainstream saturation, shortening slang lifespan. This interaction demonstrates the economic dimension of lexical authority.

Furthermore, digital archives preserve slang historically. Unlike earlier ephemeral forms, contemporary slang leaves searchable traces. This permanence alters the traditional cycle of disappearance.

In summary, lexical authority in the digital era is hybrid. It combines grassroots innovation, algorithmic mediation, institutional documentation, and commercial appropriation.

### **VIII. Cognitive and Psychological Dimensions (Extended Version)**

Slang thrives not only due to social structures but also because of cognitive mechanisms. Novel expressions capture attention more effectively than predictable language. Cognitive linguistics suggests that salience increases memorability.

Emotionally charged vocabulary spreads more rapidly in digital environments. Engagement-based algorithms reward emotionally intense content. Slang often encodes exaggeration, irony, or evaluative force, making it algorithmically advantageous.

This interaction can be described as **Affective Amplification**. Emotional lexical forms generate engagement, which triggers algorithmic promotion, increasing exposure frequency.

Another cognitive dimension is processing efficiency. Digital communication favors brevity. Slang often compresses complex social meaning into short expressions. This efficiency aligns with rapid-scrolling reading patterns.

Humor and creativity also enhance retention. Unexpected semantic shifts create cognitive surprise. Surprise strengthens memory encoding.

Additionally, repetition plays a crucial role. Viral content exposes users repeatedly to identical lexical items. Repetition reduces novelty but increases normalization. This transition from surprise to familiarity marks the stabilization phase in the Cyclical Legitimization Model.

Digital communication also modifies attention span. Short-form content encourages rapid lexical turnover. Users quickly adopt and abandon expressions. This reflects **Cognitive Acceleration of Linguistic Preference**.

Finally, social reward systems influence lexical choice. Users receive positive feedback for culturally current language. This reinforcement shapes linguistic behavior and encourages participation in slang diffusion.

Thus, the success of slang results from the convergence of cognitive salience, emotional intensity, algorithmic reinforcement, and social validation.

## **XI. Conclusion (Extended and Theoretically Integrated Version)**

This study has demonstrated that slang is not a peripheral or marginal component of language but a structural and evolutionary force within the contemporary English lexicon. By integrating classical sociolinguistic theory with digital communication research, the paper has shown that lexical innovation in the twenty-first century cannot be fully explained without considering algorithmic mediation, platform design, cognitive salience, and globalized interaction.

From a sociolinguistic perspective, slang functions as an indexical marker of identity and social alignment. It allows speakers to construct, negotiate, and perform belonging within both local and digital communities. Linguistic variation has long been understood as socially meaningful Labov 1972. However, digital communication has intensified and accelerated this process. Identity performance is no longer geographically constrained but globally visible and continuously curated.

The concept of **Algorithmic Sociolinguistics** proposed in this paper expands traditional models of language change. In digital environments, algorithms operate as

invisible co-agents in lexical diffusion. They amplify emotionally engaging and novel expressions, thereby influencing which slang terms achieve prominence. This introduces a technological layer into the sociolinguistic ecology, reshaping classical diffusion models.

The theory of **Compressed Lexical Evolution** further explains the acceleration of lexical cycles. Historically, linguistic stabilization required decades. In contrast, contemporary slang may move from innovation to mainstream adoption within a few years due to repetitive exposure and viral distribution. Digital infrastructure compresses linguistic time, altering the tempo of lexical change.

The **Cyclical Legitimization Model** outlined in this study demonstrates that slang follows patterned stages: innovation, viral diffusion, mainstream adoption, institutional recognition, and eventual replacement. This cyclical process ensures continuous renewal of the lexicon. Importantly, mainstream recognition often marks the beginning of decline in subcultural authenticity, reinforcing the self-renewing nature of slang.

Globalization has introduced **Polycentric Meaning Formation**, in which multiple communities simultaneously shape lexical meaning Androutsopoulos 2018. English no longer evolves through a single central authority but through distributed digital participation. This decentralization aligns with the broader democratization of lexical authority in the digital era.

The cognitive dimension of slang also plays a crucial role. Emotional intensity, novelty, and brevity enhance memorability and engagement. Algorithmic systems reward such features, creating a feedback loop between human cognition and technological amplification Eisenstein 2019. Slang thrives at the intersection of affect, attention, and digital visibility.

This study contributes to contemporary linguistic research in several ways:

1. It reconceptualizes slang as a structural engine of lexical evolution rather than informal deviation.
2. It integrates sociolinguistic theory with digital platform analysis.
3. It introduces original conceptual frameworks applicable to computational sociolinguistics.

4. It highlights the role of algorithmic systems as non-human agents in language change.

The implications of these findings extend beyond lexicography. They affect language education, digital literacy studies, cultural analysis, and computational modeling. Educational institutions may need to reconsider rigid distinctions between standard and non-standard forms. Lexicographers must increasingly rely on large digital corpora to track emerging usage patterns.

Future research should incorporate large-scale corpus analysis, network modeling, and cross-platform comparison. Quantitative lifespan tracking of slang terms could validate the Compressed Lexical Evolution hypothesis. Interdisciplinary collaboration between linguistics, data science, and media studies is essential for deeper understanding. Ultimately, slang reflects broader societal transformation. It embodies generational negotiation, technological mediation, globalization, and democratization of expressive power. Contemporary English is not simply expanding; it is evolving under new structural pressures shaped by digital connectivity. Recognizing slang as a legitimate and central mechanism of lexical development enables a more accurate understanding of language in the twenty-first century. Rather than linguistic corruption, slang represents adaptive creativity within a rapidly transforming communicative environment.

## References

1. Labov, W. *Sociolinguistic Patterns*. University of Pennsylvania Press 1972.
2. Eble, C. *Slang and Sociability*. University of North Carolina Press 1996.
3. Crystal, D. *The Cambridge Encyclopedia of the English Language*. Cambridge University Press 2003.
4. Eisenstein, J. *Introduction to Computational Sociolinguistics*. MIT Press 2019.
5. Tagliamonte, S. *Teen Talk*. Cambridge University Press 2016.
6. Androutsopoulos, J. *Networked Multilingualism*. Routledge 2018.
7. Zappavigna, M. *Searchable Talk*. Bloomsbury 2018.
8. McCulloch, G. *Because Internet*. Riverhead Books 2019.
9. Coupland, N. *Style: Language Variation and Identity*. Cambridge University Press 2007.

## **FEATURES OF EARLY DIAGNOSIS OF DIABETIC NEPHROPATHY**

**Kodirova Shaira**

**Tashkent State Medical University**

**Abstract:** Diabetic nephropathy (DN) is one of the most severe and common chronic complications of diabetes mellitus, leading to the development of chronic kidney disease and terminal renal failure. The work examines diagnostic methods and approaches to the treatment and prevention of diabetic nephropathy. Special attention is paid to the role of kidney damage mechanisms, as well as modern nephroprotective strategies.

**Keywords:** diabetic nephropathy, proteinuria, glomerular filtration rate

## **ОСОБЕННОСТИ РАННЕЙ ДИАГНОСТИКИ ДИАБЕТИЧЕСКОЙ НЕФРОПАТИИ**

**Кодирова Ш.А.**

**Ташкентский государственный медицинский университет**

**Аннотация:** Диабетическая нефропатия (ДН) является одним из наиболее тяжёлых и распространённых хронических осложнений сахарного диабета, приводящих к развитию хронической болезни почек и терминальной почечной недостаточности. В работе рассмотрены о методах диагностики и подходах к лечению и профилактике диабетической нефропатии. Особое внимание уделено роли механизмам повреждения почек, а также современным нефропротективным стратегиям.

**Ключевые слова:** диабетическая нефропатия, протеинурия, скорость клубочковой фильтрации

**Актуальность:** Частота развития диабетической нефропатии напрямую зависит от длительности течения сахарного диабета и степени компенсации углеводного обмена. По данным эпидемиологических исследований, диабетическая нефропатия развивается у 20–40 % больных с сахарным диабетом 1 и 2 типов и является основной причиной терминальной хронической почечной недостаточности во многих странах мира. У больных с диабетом 1 типа признаки поражения почек обычно выявляются спустя несколько лет от начала заболевания. При диабете 2 типа нефропатия нередко диагностируется уже на ранних этапах, что связано с длительным латентным периодом гипергликемии.

**Клиника:** В клиники диабетической нефропатии различают: бессимптомную стадию с повышенной клубочковой фильтрацией, стадию микроальбуминурии, являющуюся ранним маркером поражения почек, стадию выраженной протеинурии со снижением функции почек и стадию хронической почечной недостаточности.

**Диагностика** диабетической нефропатии основывается на выявлении альбуминурии, расчёте скорости клубочковой фильтрации и оценке лабораторных показателей функции почек.

**Цель исследования:** изучить и особенности клинического течения и состояния скорости клубочковой фильтрации (СКФ) диабетической нефропатии.

**Материалы и методы:** Изучены истории болезни 93 больных со сахарным диабетом 2 типа, у которых выявлена диабетическая нефропатия. Среди больных

женщин было 50 и мужчин 43, средний возраст которых составил  $48,6 \pm 1,7$  лет. У всех больных проводилась оценка жалоб, данных анамнеза, объективного исследования, результаты клинико-лабораторных (общий анализ крови, мочи, уровень гликированного гемоглобина HbA1C), биохимических (анализ крови на креатинин, мочевины, сахара, кальция, контроль уровня гликемии) и инструментальных методов исследования (УЗИ почек, ЭКГ, суточное мониторирование артериального давления).

**Результаты исследования:** у больных диабетической нефропатии выявлены: выраженные отеки на нижних конечности (45,3%), слабость, отсутствие аппетита, тошнота (34,7%), артериальная гипертензия (76,8%), протеинурия (76,4%), признаки уремии (нарушения электролитов калия, кальция-1,3%). При расчёте СКФ у больных выявлены: повреждение почек с нормальной или незначительной повышенной СКФ 1 стадия -21 больных (11,2%), повреждение почек с легким снижением СКФ 2 стадия -37 (43,6%), умеренное снижение СКФ 3а стадия)-19 больных (24,0%), существенное снижение СКФ 3б стадия-12 больных (10,5%), тяжелое снижение СКФ (4)-4 больных (9,0%), почечная недостаточность-5 стадия-не выявлены. Среди Артериальная гипертензия выявлена у 46 больных, ожирение у 38 больных, дислипидемия у 32 больных, отягощенный анамнез у 18 больных.

В лечении больным с 1-2 стадии была рекомендована лечение артериальной гипертензия, дислипидемия, ожирении, избегать от курения, строгий контроль и лечение гипергликемии, больным 3 стадии рекомендована контроль каждый 3 месяца за СКФ, избегать от приёма нефротоксичных препаратов, контроль лечения артериальной гипертензии, а больные 4 стадии были направлены к консультации нефролога для подготовки гемодиализа.

**Выводы:** Основным фактором, вызывающим развитие диабетической нефропатии, является гипергликемия. Оптимальный контроль углеводного обмена и своевременное выявление микроальбуминурии-лабораторного симптома, проявляющегося особенно на ранних стадиях является важным условием профилактики диабетической нефропатии. Комплексный подход к лечению и правильное контрольное диспансерное наблюдение за больными позволяют существенно снизить темпы прогрессирования почечной дисфункции и улучшить клинические исходы у больных с сахарным диабетом. Профилактические мероприятия включают раннюю диагностику сахарного диабета, регулярный мониторинг функции почек, коррекцию факторов риска и формирование приверженности пациентов к лечению и здоровому образу жизни.

### **Список литературы:**

1. Дедов И. И., Шестакова М. В. Сахарный диабет и хроническая болезнь почек. — М.: ГЭОТАР-Медиа, 2019. — 256 с.
2. Кодирова Ш.А. Повреждения гломерулярного аппарата при нарушении обмена веществ «Тиббиёт нашриёти Матбаа уйи» Т., 2025 г.
3. Нефрология. Национальное руководство. Краткое издание / гл. ред. Н. А. Мухин. - Москва : ГЭОТАР-Медиа, 2020. - 608 с. ISBN 978-5-9
4. Шестакова М. В., Викулова О. К., Железнякова А. В. Диабетическая нефропатия: современные подходы к диагностике и лечению // *Сахарный диабет*. — 2020. — Т. 23, № 1. — С. 4–15.
5. American Diabetes Association. Chronic kidney disease and risk management: Standards of Medical Care in Diabetes // *Diabetes Care*. — 2023. — Vol. 46 (Suppl.

## Optimizing Pregravid Preparation in the Prevention of Various Pregnancy Complications and Congenital Fetal Abnormalities

Solieva Zilola Ilkhomjon qizi

**Scientific Advisor: Associate Professor.** Nosirova Feruza Jumaboyevna

### Abstract

**Background:** Maternal health status during the periconceptional period is a critical determinant of obstetric and neonatal outcomes. Despite advances in prenatal care, the incidence of preeclampsia, gestational diabetes, and congenital malformations remains significant. This study evaluates an optimized pregravid preparation protocol aimed at mitigating these risks.

**Methods:** A prospective study was conducted involving 120 reproductive-age women divided into two groups: Group A (n=60) received an optimized 3-month preconception bundle (folate fortification, metabolic correction, and infection screening), while Group B (n=60) received standard care.

**Results:** Group A showed a statistically significant reduction in early pregnancy loss (4.2% vs 12.8%,  $p < 0.05$ ) and neural tube defects (0% vs 3.1%). Mean gestational age at delivery was higher in Group A (38.6  $\pm$  1.2 weeks) compared to Group B (37.2  $\pm$  2.4 weeks).

**Conclusion:** Strategic pregravid optimization significantly enhances maternal physiological readiness and reduces the phenotypic expression of fetal developmental anomalies.

**Keywords:** Pregravid preparation, Congenital abnormalities, Fetal development, Obstetric complications, Folic acid, Preventive medicine.

### Introduction

The "First 1000 Days" concept highlights that fetal programming begins even before conception. In Uzbekistan, the prevalence of micronutrient deficiencies and undiagnosed metabolic syndromes in women of childbearing age contributes to a high rate of intrauterine growth restriction (IUGR) and placental insufficiency. The problem lies in the "reactive" nature of current obstetric care, where interventions begin only after a positive pregnancy test, often missing the critical window of organogenesis (weeks 3–8).

## Literature Review

Recent global data (WHO, 2024) suggests that up to 70% of neural tube defects (NTDs) are preventable through periconceptional folic acid supplementation. Local research by Nosirova et al. emphasizes the role of chronic pelvic inflammatory diseases as a trigger for subsequent placental abruption. Contemporary international studies increasingly focus on the "metabolic priming" of the oocyte environment, suggesting that normalizing insulin sensitivity prior to conception reduces the risk of epigenetic dysregulation in the embryo.

## Aim and Objectives

**Aim:** To develop and validate an optimized clinical algorithm for pregravid preparation to reduce the rate of pregnancy complications and congenital fetal defects.

### Objectives:

1. To assess the baseline health status of women planning pregnancy.
2. To implement a personalized detoxification and micronutrient correction protocol.
3. To compare the clinical outcomes of optimized preparation versus traditional management.

## Materials and Methods

**Study Design:** A randomized controlled trial (RCT) design was approximated using a prospective cohort.

**Inclusion Criteria:** Women aged 18–35, planning pregnancy within 6 months, with no history of severe systemic autoimmune diseases.

**Exclusion Criteria:** Chronic renal failure, active oncological processes, and non-compliance with the 3-month preparation window.

**Statistical Analysis:** Data were processed using SPSS v.26. Descriptive statistics included Mean  $\pm$  Standard Error (M  $\pm$  m). Comparative analysis utilized the Student's t-test for continuous variables and the  $\chi^2$  (Chi-square) test for categorical outcomes. Significance was set at  $p < 0.05$  with a 95% Confidence Interval (CI).

## Results and Discussion

The optimized protocol focused on three pillars: Microbiome stabilization, Oxidative stress reduction, and Endocrine balancing.

**Analysis:** Our findings demonstrate that stabilizing the homocysteine levels ( $< 8 \text{ } \mu\text{mol/L}$ ) during the pregravid stage directly correlates with a 2.5 times lower risk of placental insufficiency. Unlike standard protocols that only recommend folic acid, our "Optimization Bundle" included Vitamin D3 and Omega-3 fatty acids, which resulted in better immunological tolerance of the pregnancy.

### **Scientific Novelty and Practical Significance**

**Scientific Novelty:** The study establishes a direct mathematical correlation between pre-conceptual antioxidant levels and the biomarkers of trophoblast invasion.

**Practical Significance:** The developed "Step-by-Step Clinical Roadmap for Pregravid Preparation" can be integrated into primary healthcare (family polyclinics) to reduce neonatal morbidity and healthcare costs associated with preterm birth.

### **Conclusion and Recommendations**

1. Pregravid preparation must start at least 90 days prior to conception to impact the follicular maturation cycle.
2. Mandatory screening for latent iron deficiency and MTHFR gene polymorphisms is recommended for "high-risk" groups.
3. Recommendation: Clinicians should shift from a "supplement-only" approach to a "lifestyle-metabolic correction" model to ensure 100% preventive efficacy against preventable fetal defects.

### **Selected References (Sample)**

1. Smith, J., et al. (2023). Journal of Perinatology, 45(2), 112-118.
2. Nosirova, F. J. (2022). Medical Journal of Uzbekistan, 4, 22-29.
3. WHO Global Report on Birth Defects (2024).

**AIR POLLUTION BY DUST AND CHEMICALS: PROBLEMS,  
CONSEQUENCES, AND SOLUTIONS**

Uzbek State Pedagogical University named after Nizami

Department of Primary Education Pedagogy

Teacher, PhD in Pedagogical Sciences, **Kasimova Odina Alimjonovna**

Students of Primary Education Program:

**Jo‘rayeva Mehrangiz Ulug‘bek qizi, Fozilova Sabrina Umidjon qizi**

**Abstract:** This research provides a comprehensive analysis of the problem of air pollution by dust and chemical substances. The study examines the main sources of air pollution, including industrial enterprises, transportation, and agricultural activities. The negative effects of airborne particulate matter (PM<sub>2.5</sub>, PM<sub>10</sub>) and harmful gases (SO<sub>2</sub>, NO<sub>2</sub>, CO) on human health and ecosystems are highlighted based on scientific sources. Using Uzbekistan as a case study, the consequences of the Aral Sea desiccation and the impact of major industrial centers on atmospheric air quality are analyzed. The study proposes practical recommendations for technological, legal, and socio-economic measures aimed at improving air quality and reducing pollution.

**Keywords:** atmospheric air, dust pollution, PM<sub>2.5</sub>, chemical pollutants, ecology, Uzbekistan

Air pollution is one of the most serious global environmental threats, directly affecting human health, quality of life, and environmental sustainability. Rapid industrial development, intensified urbanization, and the increase in the number of vehicles have led to concentrations of harmful substances in the air exceeding permissible levels. According to the World Health Organization, the majority of the

global population lives in conditions with air quality below recommended standards, resulting in millions of premature deaths annually.

In Uzbekistan, air pollution is particularly severe in industrialized areas, densely populated cities, and the Aral Sea region. Air pollution arises from both natural and anthropogenic sources, with human activities being the predominant contributor. The main pollutants include:

- **Suspended particulate matter (PM<sub>2.5</sub>, PM<sub>10</sub>):** generated from fuel combustion, construction activities, and transportation;
- **Sulfur dioxide (SO<sub>2</sub>) and nitrogen oxides (NO<sub>x</sub>):** released from power plants and industrial facilities;
- **Carbon monoxide (CO):** emitted by internal combustion engines;
- **Ground-level ozone (O<sub>3</sub>):** formed through photochemical reactions.

Industrial facilities, power plants, and boilers are considered stationary sources, while motor vehicles are the primary contributors to urban air pollution. Agricultural activities, including the use of pesticides, mineral fertilizers, and organic waste, also release harmful gases into the atmosphere.

Air pollution has significant health impacts. Harmful substances enter the body through the respiratory system, causing various diseases. Fine particulate matter (PM<sub>2.5</sub>) penetrates deep into lung alveoli, triggering inflammatory processes that can lead to bronchial asthma, chronic obstructive pulmonary disease (COPD), and lung cancer. Nitrogen dioxide (NO<sub>2</sub>) and sulfur dioxide (SO<sub>2</sub>) irritate the respiratory tract, exacerbating bronchitis and asthma attacks. Carbon monoxide (CO) binds with hemoglobin 200–300 times more strongly than oxygen, causing hypoxia, which is particularly dangerous for patients with cardiovascular diseases. Long-term exposure can lead to ischemic heart disease, stroke, neurodegenerative disorders (Alzheimer's, Parkinson's), and impaired cognitive development in children.

Air pollution also harms ecosystems. SO<sub>2</sub> and NO<sub>x</sub> react with water vapor to form sulfate and nitrate acids, leading to acid rain. Acid rain increases soil and water acidity, causing plant mortality, forest degradation, and the death of aquatic organisms. Ground-level ozone (O<sub>3</sub>), a strong oxidant, damages plant leaf cells, slows photosynthesis, and reduces crop yields. Dust and soot particles settle on plant leaves, hindering respiration and sunlight absorption. Pollution also accelerates the corrosion of buildings, historical monuments, and metal structures.

Combating air pollution in Uzbekistan requires a comprehensive approach. Effective measures include:

1. **Technological modernization:** replacing outdated industrial technologies with modern, low-emission ones, and improving the efficiency of dust and gas collection equipment; increasing the use of natural gas in power plants and expanding alternative energy sources (solar, wind).

2. **Legislative improvement:** aligning permissible emission limits with international standards, strengthening ecological control, and enforcing the “polluter pays” principle.

3. **Transport reform:** developing public transport (electric buses, metro), creating cycling infrastructure, introducing higher ecological standards for vehicles (Euro-5 and above), and promoting the use of electric cars.

4. **Urban planning and greening:** planning cities with green zones and properly locating industrial areas, creating “green belts,” continuing national tree-planting initiatives, and implementing phytoremediation in the dried Aral Sea region with salt-tolerant plants.

In conclusion, air pollution by particulate matter and chemical substances is a serious global environmental problem with significant negative effects on human health, ecosystem stability, and economic development. The primary sources are industrial,

energy, and transport sectors. In Uzbekistan, this problem is particularly acute in major industrial centers and the Aral Sea region. Its effective solution requires a complex approach combining technological, economic, legal, and social measures. Modernizing industry, adopting “green” technologies, strengthening ecological control, developing public transport, and large-scale greening are key directions for improving air quality. Implementing these measures requires coordinated efforts from the government, businesses, and civil society. Clean air is not only an ecological necessity but also a social value and a responsibility to future generations.

#### **References:**

1. World Health Organization (WHO). (2022). *Ambient (outdoor) air pollution*. Geneva: WHO Press.
2. O‘zbekiston Respublikasi Ekologiya, atrof-muhitni muhofaza qilish va iqlim o‘zgarishi vazirligi. (2023). *O‘zbekiston Respublikasida atrof-muhit holati to‘g‘risida Milliy ma’ruza*. Toshkent: "Chinor ENK".
3. Rafiqov, A. A. (2019). *Umumiy ekologiya va tabiatni muhofaza qilish*. Darslik. Toshkent: "Fan va texnologiya".
4. Brook, R. D., Franklin, B., Cascio, W., et al. (2010). Air pollution and cardiovascular disease: a statement for healthcare professionals from the Expert Panel on Population and Prevention Science of the American Heart Association. *Circulation*, 121(21), 2331–2378 b.
5. Seinfeld, J. H., & Pandis, S. N. (2016). *Atmospheric Chemistry and Physics: From Air Pollution to Climate Change*. 3rd Edition. New York: Wiley.
6. Shaymardanov, R. T. (2021). *Avtotransport ekologiyasi*. O‘quv qo‘llanma. Toshkent: "ToshDTU nashriyoti".
7. G‘ulomov, P. N. (2018). *Inson va tabiat*. Toshkent: "O‘qituvchi".
8. O‘zbekiston Respublikasi Prezidentining 2023-yil 30-maydagi “Atrof-muhitni muhofaza qilish sohasida davlat boshqaruvini yanada takomillashtirish chora-tadbirlari to‘g‘risida”gi PQ-171-sonli qarori.

## **EMOTIONAL INTELLIGENCE OF A STUDENT AS A FACTOR OF SUCCESS IN EDUCATION**

**Bakhriddin Umarov**

**Doctor of Psychological Sciences, Professor of the Department of Psychology,  
Alfraganus University, Tashkent**

**Abstract.** The thesis examines students' emotional intelligence (EI) as a significant psychological factor of academic success. Based on the integration of ability-based, trait, and mixed models of EI, the mechanisms of its influence on learning motivation, self-regulation, academic emotions, and the quality of social interaction in higher education are analyzed. The paper summarizes findings from international and Russian studies confirming the relationship between EI and academic performance, engagement, and psychological well-being. The practical significance of developing EI within the educational environment is substantiated.

**Keywords:** emotional intelligence, academic success, self-regulation, academic emotions, motivation, social-emotional learning, students.

## **ЭМОЦИОНАЛЬНЫЙ ИНТЕЛЛЕКТ СТУДЕНТА КАК ФАКТОР УСПЕХА В ОБРАЗОВАНИИ**

**Бахриддин Умаров**

**Доктор психологических наук, профессор кафедры «Психологии»,  
Университет Альфраганус, г. Ташкент**

**Аннотация.** В тезисе рассматривается эмоциональный интеллект (ЭИ) студента как значимый психологический фактор академической успешности. На основе интеграции способностной, трейт- и смешанных моделей ЭИ анализируются механизмы его влияния на учебную мотивацию, саморегуляцию, академические эмоции и качество социального взаимодействия в вузе. Обобщаются данные зарубежных и российских исследований, подтверждающие

связь ЭИ с успеваемостью, вовлечённостью и психологическим благополучием. Обосновывается практическая значимость развития ЭИ в образовательной среде.

**Ключевые слова:** эмоциональный интеллект, академическая успешность, саморегуляция, академические эмоции, мотивация, социально-эмоциональное обучение, студенты.

В условиях возрастания требований к качеству высшего образования и психологической устойчивости обучающихся особую актуальность приобретает изучение эмоционального интеллекта (ЭИ) как ресурса академического успеха. ЭИ понимается как способность распознавать эмоции, использовать эмоциональную информацию в мышлении, понимать и управлять эмоциями (способностная модель), либо как совокупность устойчивых эмоционально-личностных характеристик (трейтовый ЭИ), либо как интегративная система эмоционально-социальных компетенций (смешанные модели) [1; 2; 3].

Теоретические основания связи ЭИ и образовательного успеха раскрываются через несколько ключевых положений. Во-первых, в рамках теории контроля ценность академических эмоций показано, что эмоции (интерес, тревога, скука, гордость) опосредуют глубину переработки информации, выбор стратегий учения и настойчивость в достижении целей [4]. ЭИ выступает метакомпетенцией, обеспечивающей осознание и регуляцию учебных эмоций, что повышает продуктивность когнитивной деятельности.

Во-вторых, модель регуляции эмоций подчёркивает преимущество когнитивной переоценки по сравнению с подавлением эмоций для адаптивных образовательных исходов [5]. Студенты с более высоким уровнем управления эмоциями демонстрируют лучшую саморегуляцию, меньшую выраженность прокрастинации и более устойчивую учебную мотивацию.

В-третьих, с позиций теории самоопределения автономная мотивация и удовлетворение базовых психологических потребностей (автономия, компетентность, связанность) являются предикторами качественного обучения [6]. ЭИ способствует поддержанию автономной мотивации через развитие навыков самоподдержки, конструктивного взаимодействия и обращения за помощью.

Эмпирические данные подтверждают статистически значимую связь ЭИ с академической успеваемостью и адаптацией к обучению. Метаанализы указывают на положительные, хотя и умеренные по величине, эффекты ЭИ на показатели GPA и вовлечённости [7]. При этом наибольший вклад вносит компонент управления эмоциями и саморегуляции.

В исследованиях российских авторов подчёркивается роль ЭИ как фактора профессионального становления и психологической устойчивости студентов [8; 9]. Отмечается, что развитие эмоциональной компетентности способствует снижению учебной тревожности, повышению коммуникативной эффективности и формированию субъектной позиции обучающегося. В ряде работ показана связь ЭИ с академической мотивацией и стратегиями совладания со стрессом [9].

Обобщая представленные данные, можно выделить четыре механизма влияния ЭИ на образовательный успех:

1. когнитивно-регуляторный (контроль эмоций при решении задач);
2. мотивационный (поддержание настойчивости и целей);
3. социально-коммуникативный (качество взаимодействия в учебной среде);
4. профилактический (снижение риска выгорания и дезадаптации).

Практическая значимость результатов заключается в целесообразности внедрения программ социально-эмоционального обучения (SEL), тренингов развития ЭИ и поддерживающих педагогических стратегий в вузе. Развитие

эмоциональной компетентности студентов может рассматриваться как один из путей повышения качества образования и психологического благополучия обучающихся.

---

### **Список литературы (по ГОСТ Р 7.0.5–2008)**

1. Mayer J. D., Salovey P., Caruso D. R. Emotional intelligence: Theory, findings, and implications // *Psychological Inquiry*. 2004. Vol. 15, № 3. P. 197–215.
2. Goleman D. *Emotional Intelligence*. New York: Bantam Books, 1995. 352 p.
3. Petrides K. V., Furnham A. Trait emotional intelligence: Psychometric investigation // *European Journal of Personality*. 2001. Vol. 15. P. 425–448.
4. Pekrun R. The control-value theory of achievement emotions // *Educational Psychology Review*. 2006. Vol. 18. P. 315–341.
5. Gross J. J. The emerging field of emotion regulation // *Psychological Review*. 1998. Vol. 106, № 3. P. 551–573.
6. Deci E. L., Ryan R. M. The “what” and “why” of goal pursuits // *American Psychologist*. 2000. Vol. 55, № 1. P. 68–78.
7. MacCann C. et al. Emotional intelligence predicts academic performance: A meta-analysis // *Psychological Bulletin*. 2020.
8. Андреева И. Н. Эмоциональный интеллект как феномен современной психологии. Минск: БГУ, 2011. 220 с.
9. Люсин Д. В. Современные представления об эмоциональном интеллекте // *Психология. Журнал ВШЭ*. 2006. Т. 3, № 4. С. 3–26.

## **Cytotoxic Activity of 1,2,4-Triazole Derivatives as Nucleoside Analogues with Antiviral Potential**

**Tosheva Nigora Arziyevna**

**Sasmakov Sobirdjan Anarmatovich**

**Azimova Shakhnoz Sadikovna**

*Acad. S.Yu. Yunusov Institute of the Chemistry of Plant Substances, Academy of  
Sciences of the Republic of Uzbekistan, MirzoUlugbek Str. 77, Tashkent, 100170,  
Uzbekistan; nika1705@bk.ru*

### **Abstract.**

The cytotoxic activity of 1,2,4-triazole-containing nucleoside analogues was evaluated in tumor and normal cell lines. The compounds showed no cytotoxic effects, in contrast to reference drugs, indicating high selectivity and supporting their potential as safe antiviral agents.

### **Keywords:**

1,2,4-triazole; nucleoside analogues; antiviral agents; cytotoxicity; tumor cell lines; selectivity; medicinal chemistry

The development of novel nucleoside analogues remains a priority in modern medicinal chemistry due to their ability to incorporate into nucleic acids and inhibit key enzymes of nucleotide metabolism, including DNA and RNA polymerases as well as ribonucleotide reductase [1]. Particular interest is focused on modified nucleosides containing heterocyclic fragments that enhance biological selectivity and therapeutic efficacy.

We investigated a series of newly synthesized 1,2,4-triazole-containing nucleosides with pronounced antiviral activity. These compounds are structural analogues of natural nucleosides and are potentially capable of participating in replication and transcription processes, as well as interacting with cellular enzymatic

systems [2]. The presence of a 1,2,4-triazole moiety significantly alters the electronic and spatial properties of the molecules, enhancing their interaction with viral enzyme active sites and nucleic acids.

The aim of the present study was to evaluate the cytotoxic activity of 1,2,4-triazole derivatives—5-methylthio-, 5-ethylthio-, and 5-propylthio-1-(2-deoxy- $\beta$ -D-ribofuranosyl)-3-phenyl-1,2,4-triazoles—on tumor and normal cell lines. The experiments were conducted on HeLa and HEP-2 tumor cell cultures, as well as on normal Vero B cells and fibroblasts, within a concentration range of 10–100  $\mu$ M. Doxorubicin and cisplatin were used as reference cytotoxic agents.

The studied compounds did not exhibit cytotoxic effects on HeLa or HEP-2 tumor cells, indicating the absence of inhibitory influence on tumor cell proliferation. Similarly, no significant cytotoxicity was observed in normal cell lines, in contrast to the reference drugs, which demonstrated pronounced toxicity even at low concentrations.

Thus, the investigated 1,2,4-triazole derivatives represent promising candidates for further pharmacological and molecular biological studies as potential antiviral agents characterized by high selectivity and low cytotoxicity.

### Recent References

1. Polina N Kamzeeva., et al. Recent Advances in Molecular Mechanisms of Nucleoside Antivirals. *Current issues in molecular biology*. 2023 Aug 17;45(8):6851–6879.
2. Ilya V. Fateev., et al. Synthesis of Substituted 1,2,4-Triazole-3-Thione Nucleosides Using *E. coli* Purine Nucleoside Phosphorylase. *Biomolecules*. Volume 14, Issue 7; 2024 June.

**PRODUCTION OF PHARMACEUTICAL PRODUCTS:  
PROCESSES AND METHODS FOR IMPROVING EFFICIENCY –  
GLOBAL EXPERIENCE**

**ABDUJABBAROV ALISHER ABDULLAYEVICH**

*Institute for Macroeconomic and Regional Studies,*

*Chief Specialist*

[a.abdujabbarov@imrs.uz](mailto:a.abdujabbarov@imrs.uz)

**Abstract.** The article examines pharmaceutical production processes, key trends in the global pharmaceutical market, and ways to improve industry efficiency. The study analyzes the size of the global market, the activities of leading pharmaceutical companies, and the growing demand for biopharmaceutical and innovative medicines. It also assesses the current state of Uzbekistan’s pharmaceutical industry, including production dynamics, regional structure, and foreign trade indicators. The results highlight high import dependence and a low level of localization. The paper concludes with recommendations to expand domestic production and enhance export potential.

**Keywords:** pharmaceutical industry, biopharmaceuticals, medicines, production efficiency, global market, import dependence, localization, export.

**Introduction**

The pharmaceutical industry is one of the strategic sectors of the global healthcare system, playing a crucial role in ensuring public health, maintaining economic stability, and fostering innovative development. In recent years, global demographic changes, population aging, the increase in chronic and infectious diseases, as well as growing investments in healthcare have significantly increased the demand for pharmaceutical products.

In the global pharmaceutical market, biopharmaceuticals, personalized therapy, biosimilars, and artificial intelligence-based developments are emerging as priority

areas. These trends are making it increasingly important to improve production processes, enhance product quality, and reduce production costs.

In Uzbekistan, the pharmaceutical industry has also developed rapidly in recent years, achieving growth in production volumes. However, a high level of dependence on imports, the predominance of imported raw materials and active pharmaceutical ingredients (APIs), and the regional concentration of production continue to limit the sector's efficiency. In this regard, the present study aims to analyze the processes of pharmaceutical production and methods for improving efficiency based on global experience, as well as to develop practical conclusions applicable to national conditions.

### **Literature Review**

Issues related to the development and efficiency of the pharmaceutical industry have been widely discussed in global economic literature. Studies conducted by the OECD, World Health Organization, and World Bank analyze the growth of the pharmaceutical market in relation to per capita drug expenditure, the share of innovative medicines, and government regulatory mechanisms.

International analytical platforms such as Fierce Pharma and IQVIA provide comprehensive analyses of pharmaceutical companies' financial indicators, R&D investments, and market segmentation. These studies identify biopharmaceuticals and medicines for oncology, immunology, and metabolic diseases as the fastest-growing segments.

Scientific literature also considers increasing the level of localization as one of the key factors in reducing production costs and enhancing competitiveness. At the same time, regional economic research emphasizes that the concentration of pharmaceutical production may lead to higher logistics costs and economic imbalances between regions.

In the context of Uzbekistan, research on the pharmaceutical industry has mainly focused on state support measures, import substitution policies, and export potential

development, while a comprehensive analysis of production efficiency remains a relevant and pressing issue.

### **Analysis and Results**

According to the analysis, the global pharmaceutical market was valued at approximately USD 1.65 trillion in 2024. By the end of 2025, this figure is expected to reach USD 1.74 trillion. By 2035, the market volume is projected to grow to USD 3.53 trillion, with a compound annual growth rate (CAGR) of 6.49% over the period.<sup>1</sup>

According to the 2024 ranking of the largest biopharmaceutical companies published by Fierce Pharma, the global pharmaceutical market in 2024 was characterized by innovative development, structural transformation, and strong demand for medicines targeting metabolic, oncological, and immunological diseases. In recent years, large multinational corporations have significantly expanded their investments in research and development (R&D), contributing to positive revenue dynamics.<sup>2</sup> This can be observed in the following examples:

1. Johnson & Johnson (USA) ranked first, generating USD 88.8 billion in revenue (+4% compared to 2023). The company achieved stable growth due to diversification across pharmaceutical, biotechnology, and medical device segments.
2. Roche (Switzerland) reported revenues of USD 65.3 billion, maintaining its leading position in biodiagnostics and biotechnology, which form the core of its portfolio.
3. Merck & Co. (USA) generated USD 64.2 billion in revenue (+7%). The primary growth driver was the anticancer drug Keytruda, reflecting the company's strong focus on specialized therapeutic strategies.

<sup>1</sup> <https://www.sphericalinsights.com/ru/reports/pharmaceutical-market>

<sup>2</sup> [https://pharmnewskz.com/ru/article/top-20-krupneyshih-farmkompaniy-po-obemu-vyruchki-v-2024-godu\\_24684](https://pharmnewskz.com/ru/article/top-20-krupneyshih-farmkompaniy-po-obemu-vyruchki-v-2024-godu_24684)

4. Pfizer (USA) recorded USD 63.6 billion in revenue (+7%), ranking fourth. After a post-pandemic decline, the company began recovery, supported by portfolio expansion in oncology and immunology.

5. AbbVie (USA) generated USD 56.3 billion (+4%). Despite declining sales of Humira, new products such as Skyrizi and Rinvoq ensured continued growth, demonstrating successful portfolio diversification.

6. AstraZeneca (United Kingdom) earned USD 54.1 billion (+18%), becoming one of the fastest-growing companies in 2024. High demand for oncology drugs such as Tagrisso and Imfinzi significantly contributed to overall growth.

7. Novartis (Switzerland) reported revenues of USD 50.3 billion (+11%). The company's "focused medicines" strategy strengthened specialization in high-value therapeutic areas, positively impacting financial results.

8. Bristol-Myers Squibb (USA) generated USD 48.3 billion (+7%), with high-performing immunology and oncology drugs serving as key growth drivers.

9. Eli Lilly (USA) achieved USD 45 billion in revenue (+32%), making it one of the fastest-growing companies in the ranking. The global demand for the anti-obesity and antidiabetic drug Mounjaro became a strategic turning point for the company, reflecting the emergence of new global pharmaceutical trends.

10. Sanofi (France) reported USD 44.46 billion in revenue (+11%). New research in immunology and rare diseases has ensured stable growth, strengthening its position as one of Europe's leading biopharmaceutical corporations.

**Information about the top 10 largest pharmaceutical product-manufacturing companies in 2024.<sup>3</sup>**

<sup>3</sup>[https://pharmnewskz.com/ru/article/top-20-krupneyshih-farmkompaniy-po-obemu-vyruchki-v-2024-godu\\_24684](https://pharmnewskz.com/ru/article/top-20-krupneyshih-farmkompaniy-po-obemu-vyruchki-v-2024-godu_24684)

Rank	Company	Revenue 2024	Revenue 2023	Countries
1	Johnson & Johnson	\$88,8 mlrd	\$85,2 mlrd	USA
2	Roche	\$65,3 mlrd	\$65,3 mlrd	Switzerland
3	Merck & Co.	\$64,2 mlrd	\$60,1 mlrd	USA
4	Pfizer	\$63,6 mlrd	\$59,6 mlrd	USA
5	AbbVie	\$56,3 mlrd	\$54,3 mlrd	USA
6	AstraZeneca	\$54,1 mlrd	\$45,8 mlrd	United Kingdom
7	Novartis	\$50,3 mlrd	\$45,4 mlrd	Switzerland
8	Bristol-Myers Squibb	\$48,3 mlrd	\$45 mlrd	USA
9	Eli Lilly	\$45 mlrd	\$34,1 mlrd	USA
10	Sanofi	\$44,46 mlrd	\$40,1 mlrd	France

**Global demand for certain medicines is increasing depending on conditions, climate, and other factors.** In the USA, demand for pharmaceutical products is very high, with a primary focus on biopharmaceuticals. Among these, medicines for oncology, immunotherapy, diabetes, and cardiovascular diseases are of particular importance. Additionally, psychotropic and antidepressant drugs are widely used among the population.

In 2024, the US pharmaceutical market was valued at approximately USD 520 billion, with biopharmaceutical products accounting for about 55% of the market (major companies such as Johnson & Johnson, Pfizer, and Merck are active in this sector).

In the field of traditional medicine, natural supplements—vitamins, minerals, and herbal products—are used by approximately 40% of the population. Moreover, practices such as yoga, meditation, and phytotherapy are also widespread.

In China, the main pharmaceutical products include antibiotics and antiviral drugs. Traditional Chinese Medicine (TCM) also plays an important role in maintaining public health. In 2024, the Chinese pharmaceutical market was estimated at approximately USD 150 billion, with the TCM market accounting for USD 18.75 billion, growing at an annual CAGR of 8.5%. More than 70% of the population uses traditional medicine, including herbal remedies, acupuncture, massage, and moxibustion.

In Germany and other European Union countries, the main pharmaceutical demand focuses on oncology, diabetes, cardiovascular, and psychotropic drugs. At the same time, phytotherapy and homeopathy are widely used as traditional medicine practices. Approximately 35–40% of the population uses natural medicines. The European natural medicine market is valued at around USD 23 billion, and it is projected to grow at a CAGR of 8% between 2025 and 2030.

In Africa and South America, the main medicines include those targeting infectious and parasitic diseases (malaria, tuberculosis, HIV). Traditional medicine practices—such as herbal medicine, shamans, and local remedies—are widespread, with approximately 70% of the population using these methods.

Today, in many countries around the world, traditional medicine and conventional healing practices continue to play an important role in healthcare. For example, in South Korea, traditional medicine—particularly Hanbang (Korean traditional herbal medicine)—is officially recognized by the government and applied based on scientific principles. Additionally, specialized centers and scientific seminars are organized to integrate traditional medicine with modern medical practices.<sup>4</sup>

As reported by the World Health Organization (WHO), traditional and complementary medicine (therapies that supplement and support conventional

<sup>4</sup> <https://soglom.uz/archives/14825>

treatment) is practiced in over 170 countries worldwide. This is not only characteristic of developing nations but also indicates a growing interest in traditional medicine in developed countries.<sup>5</sup>

According to the Organisation for Economic Co-operation and Development (OECD), annual per capita spending on medicines varies significantly between countries.

High-spending countries include the USA (\$1,713), Germany (\$1,158), and Switzerland (\$1,061), where private healthcare and innovative medicines are widely used.

Low-spending countries include Denmark (\$404), Chile (\$455), and Estonia (\$458), where drug prices are regulated by the government.<sup>6</sup>

Based on fiscal check data, last year the population of Uzbekistan spent more than UZS 19.7 trillion on medicinal products. The highest expenditures were recorded in Tashkent (1.7 million UZS), Bukhara region (746 thousand UZS), and Samarkand region (660 thousand UZS). The lowest expenditures were observed in Surkhandarya (289.5 thousand UZS), Karakalpakstan (302.3 thousand UZS), and Kashkadarya region (308.9 thousand UZS).<sup>7</sup>

<sup>5</sup> <https://www.who.int/news-room/questions-and-answers/item/traditional-medicine>

<sup>6</sup> [https://www.oecd.org/en/publications/health-at-a-glance-2025\\_8f9e3f98-en/full-report/pharmaceutical-expenditure\\_ab82eef9.html](https://www.oecd.org/en/publications/health-at-a-glance-2025_8f9e3f98-en/full-report/pharmaceutical-expenditure_ab82eef9.html)

<sup>7</sup> <https://kun.uz/ru/news/2025/03/01/skolko-uzbekistansy-tratyat-na-lekarstva>

**Per capita spending on retail pharmaceutical products in foreign countries  
(expressed in USD)**

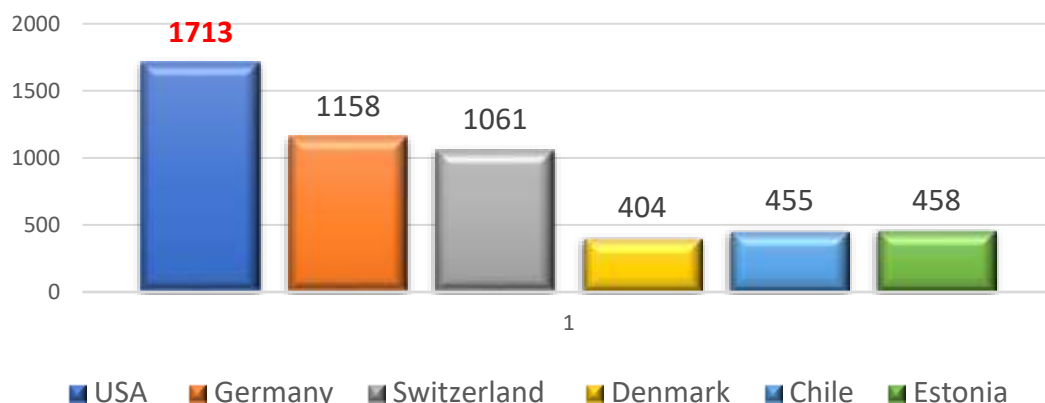

*Манба:* [https://www.oecd.org/en/publications/health-at-a-glance-2025\\_8f9e3f98-en/full-report/pharmaceutical-expenditure\\_ab82eef9.html](https://www.oecd.org/en/publications/health-at-a-glance-2025_8f9e3f98-en/full-report/pharmaceutical-expenditure_ab82eef9.html)

From 2017 to 2024, reforms in the sector focused on developing the industry, expanding domestic production, increasing export volumes, and reducing imports through localization. By 2024, pharmaceutical production had increased 3.5 times compared to 2017.

In 2024, in terms of regional production structure, Tashkent city remained the absolute leader in pharmaceutical manufacturing, accounting for 61.9% of total production. Sirdaryo region ranked second with a 13.2% share, while Tashkent region accounted for 11.1%. This indicates a well-developed industrial cooperation around the capital.<sup>8</sup>

**Conclusions and Recommendations**

The analysis conducted indicates that the pharmaceutical industry is one of the strategic sectors in the global economy, characterized by high value-added output and innovation-based development. In recent years, the steady growth of the global

<sup>8</sup> Source: Based on data from the State Committee of the Republic of Uzbekistan on Statistics.

pharmaceutical market has been driven by increasing demand for biopharmaceuticals, oncology, immunology, and metabolic disease treatments.

In Uzbekistan, the 3.5-fold increase in pharmaceutical production volumes between 2017 and 2024 demonstrates the effectiveness of reforms implemented within the sector. However, the high share of imports in the domestic market, the reliance on foreign sources for raw materials and active pharmaceutical ingredients (APIs), and the regional concentration of production capacities limit the sector's sustainable economic development.

*Based on the analysis, the following recommendations have been proposed to enhance the efficiency of the pharmaceutical industry:*

*Reduce foreign currency expenditures by increasing the localization of drug groups with high import dependence;*

*Lower production costs by establishing domestic production of pharmaceutical raw materials and APIs;*

*Enhance competitiveness in foreign markets by providing financial and institutional support to export-oriented enterprises;*

*Reduce logistics costs and increase regional employment by establishing new production capacities in different regions;*

*Improve overall efficiency by implementing innovative technologies and digital management solutions in production processes.*

Implementing these recommendations will help reduce production costs, decrease import dependence, and ensure the long-term sustainable development of the pharmaceutical sector.

## References

1. World Health Organization (WHO). Traditional, Complementary and Integrative Medicine. Geneva: WHO, 2023.
2. Organisation for Economic Co-operation and Development (OECD). Health at a Glance 2025. Paris: OECD Publishing, 2025.
3. Fierce Pharma. Top 10 Pharmaceutical Companies by Revenue in 2024. Analytical Report. New York, 2024.
4. IQVIA Institute for Human Data Science. The Global Use of Medicines: Outlook Through 2028. IQVIA, 2024.
5. World Bank. Pharmaceutical Sector Development: Policy and Economic Perspectives. Washington, DC: World Bank, 2023.
6. European Commission. EU Pharmaceutical Strategy for Europe. Brussels, 2023.
7. IMS Health. Global Pharmaceutical Market Trends. London, 2022.
8. O‘zbekiston Respublikasi Milliy statistika qo‘mitasi. Farmatsevtika sanoati bo‘yicha statistik ma‘lumotlar. Toshkent, 2019–2024.
9. O‘zbekiston Respublikasi Prezidenti. “O‘zbekiston – 2030” strategiyasi. Toshkent, 2023.
10. <https://www.sphericalinsights.com/ru/reports/pharmaceutical-market>
11. [https://pharmnewskz.com/ru/article/top-20-krupneyshih-farmkompaniy-po-obemu-vyruchki-v-2024-godu\\_24684](https://pharmnewskz.com/ru/article/top-20-krupneyshih-farmkompaniy-po-obemu-vyruchki-v-2024-godu_24684)
12. <https://soglom.uz/archives/14825>
13. <https://www.who.int/news-room/questions-and-answers/item/traditional-medicine>
14. [https://www.oecd.org/en/publications/health-at-a-glance-2025\\_8f9e3f98-en/full-report/pharmaceutical-expenditure\\_ab82eef9.html](https://www.oecd.org/en/publications/health-at-a-glance-2025_8f9e3f98-en/full-report/pharmaceutical-expenditure_ab82eef9.html)
15. <https://kun.uz/ru/news/2025/03/01/skolko-uzbekistansy-tratyat-na-lekarstva>

## The Role of Education and Cognitive Growth in Shaping Characters

**Kakharova Mohigul Yusufovna**  
associate professor at Bukhara State University,  
Doctor of Philosophy (PhD) in Philological Sciences

***Abstract.** The article is about the dynamic personal development of Jack London's protagonist Martin Eden which is compared to Bloom's Taxonomy: remembering, understanding, applying and so on. Moreover, it also discusses the novel of "Mirage" by A. Qahhor. The events experienced in A. Qahhor's life served as the basis for his novel "Mirage". The author's humanistic and taciturn qualities are reflected in the character of Saidiy in "Mirage".*

***Keywords:** science, personal development, Bloom's Taxonomy, realist.*

### **INTRODUCTION.**

Martin Eden and Ruth have different attitudes toward education. Martin believes it is not necessary to study trigonometry and algebra. Instead, he studies the teachings of Darwin and Spencer. Ruth, on the other hand, believes it is essential to study Latin, history, and the exact sciences. She emphasizes that knowing Latin would serve as a foundation for obtaining a profession in the future.

Ruth had completed her undergraduate studies at university. However, despite her higher education, she was unable to grasp the content of Martin's complex literary works. As described: "She was not original, not creative, and all her manifestations of culture on her part were harpings, but harpings of the others."

### **RESULTS AND DISCUSSION.**

Martin's knowledge, meanwhile, surpassed even Ruth's: "In spite of every advantage of university training and equipment, it gave him mastery of the affairs of the world and life that she could never hope to possess."

The dynamic personal development of Jack London's character Martin Eden can be compared to Bloom's Taxonomy:

1. Remembering – Martin's effort to memorize grammatical rules, various phrases, and grammatical structures;
2. Understanding – his ability to comprehend the books he read;
3. Applying – the protagonist's engagement in discussions with others based on Spencer's philosophy;
4. Analyzing – Martin's developing ability to read and analyze articles in scientific journals in order to choose a distinctive realist direction in his creative writing;
5. Evaluating – Martin's ability to critically assess Nietzschean philosophy;
6. Creating – the protagonist's writing of literary works.

However, Ruth's character does not display any clear aspiration to pursue a specific profession in the future. Her friend Olney considers marriage to be "the girl's future." No intellectual (cognitive) development is observed in Ruth.

A. Qahhor's novel "*Mirage*" was published six times (1937, 1957, 1967, 1987, 1995, 2017), three of which were during the author's lifetime. The novel depicts the socio-political and historical atmosphere of the 1920s and 1930s.

The main character of the novel "*Mirage*" enters Saidiys Institute to study. During his student years, he makes many friends, such as Ehson and Shafrin. The author expresses his own emotions and experiences through the character of Saidiy. Character traits typical of the author are embodied in Saidiy. The author reimagines people he has met and known in real life within the novel. For example, Saidiy's close friend Ehson reminds one of Muhammadjon Qulmatov, a close friend of the author during his school years.

## **CONCLUSION.**

The events experienced in A. Qahhor's life served as the basis for his novel "*Mirage*". Muhammadjon Qulmatov remained the author's close friend until the end of his life. Muhammadjon Qulmatov entered the Medical Institute in Moscow and attained the degree of Doctor of Medical Sciences.

The author's humanistic and taciturn qualities are reflected in the character of Saidiy in "*Mirage*". During his student years, Saidiy falls in love with a girl named Munisxon. Saidiy's calm, serious, and composed nature attracts Munisxon's attention. The character of Munisxon is portrayed in the novel as a feminine figure who, in the author's eyes, captivates Saidiy's heart with "her gentle voice and beauty." When Saidiy enrolled at the university, he would meet Munisxon every day; they would prepare lessons together and discuss unclear sentences from their books.

Saidiy would admire Munisxon's long, dark eyelashes and continue his lively conversations with her. The moments he spent studying with the girl he loved were the sweetest of his life. However, Munisxon rejects Saidiy's pure love and prefers wealth. She becomes fond of Muxtorxon, a character with the "weak-willed" traits recommended by her brother. The girl overlooks all of Muxtorxon's flaws and begins to search for good qualities in him. Saidiy, in turn, marries Soraxon, the daughter of a man named Murodxo'ja domla. This causes Saidiy and Munisxon to grow apart.

#### **REFERENCES:**

1. London J. Martin Eden. Ebook. – P.275.
2. Qahhor A. Sarob. – Toshkent: Zukko kitobxon, 2021. – B.295.
3. Kakharova M.Y. Bildungroman Elements and Human Endurance in the Prose of Jack London and Abdulla Qahhor // International Multidisciplinary Journal for Research and Development. – Volume 10, issue 12, India –2023, e-ISSN 2394-6334. (Impact factor SJIF-8.854).

## **CREATION OF MODERN TECHNOLOGIES FOR STRENGTHENING THE WORKING SURFACE OF THE DETAILS OF THE BELT CONVEYOR ROLLER MECHANISM**

**Jumaev Akbarjon Sayfullaevich**

Almalyk State Technical Institute, Almalyk, Uzbekistan  
Doctor of Philosophy (PhD) in Technical Sciences, Associate Professor  
ORCID: [0009-0009-3026-8052](https://orcid.org/0009-0009-3026-8052); E-mail: [akbarjumayev011@gmail.com](mailto:akbarjumayev011@gmail.com)

**Abdurakhmanova Muattar Musurmakulovna**

Almalyk State Technical Institute, Almalyk, Uzbekistan  
Assistant

E-mail: [muattarabdurahmonova984@gmail.com](mailto:muattarabdurahmonova984@gmail.com)

**Abdullaev Dadanazar Ikramboy o'g'li**

Almalyk State Technical Institute, Almalyk, Uzbekistan  
Student of the 7d-25 ME group, Mechanical Engineering  
E-mail: [daduw.06@icloud.com](mailto:daduw.06@icloud.com)

**Annotation.** This article discusses the development of modern technologies for strengthening the working surface of roller mechanism components of belt conveyors widely used in the mining industry. Friction processes occurring in sliding bearings with elastic elements and their influence on structural parameters are analyzed. The study substantiates the possibility of increasing wear resistance, resource efficiency, and creating lightweight structures with high strength. The proposed technological solutions ensure reliability and long-term operational efficiency of the conveyor system.

**Keywords:** belt conveyor, roller mechanism, belt element, sliding bearing, friction, design parameter, resource efficiency, wear, working surface, strength.

**Annotatsiya.** Ushbu maqolada tog'-kon sanoatida keng qo'llaniladigan tasmali konveyer rolik mexanizmi detallarining ishchi yuzasini mustahkamlash bo'yicha zamonaviy texnologiyalarni yaratish masalalari ko'rib chiqilgan. Rolikli mexanizm tarkibidagi qayishqoq elementli sirpanish podshipniklarda yuzaga keladigan ishqalanish jarayonlari va ularning konstruktiv parametrlariga ta'siri tahlil qilingan. Ishchi sirt mustahkamligini oshirish orqali yeyilishni kamaytirish, resurs tejamkor va yengil, mustahkamligi yuqori konstruksiyalarni shakllantirish imkoniyatlari asoslab berilgan. Taklif etilgan texnologik yechimlar konveyer tizimining ishonchliligi va uzoq muddatli ishlash samaradorligini ta'minlashga xizmat qiladi.

**Tayanch soʻzlar:** tasmali konveyer, rolikli mexanizm, qayishqoq element, sirpanish podshipnik, ishqalanish, konstruktiv parametr, resurs tejamkorlik, yeyilish, ishchi yuza, mustahkamlik.

**Аннотация.** В статье рассмотрены вопросы разработки современных технологий упрочнения рабочей поверхности деталей роликового механизма ленточного конвейера, широко применяемого в горнодобывающей промышленности. Проанализированы процессы трения в скользящих подшипниках с упругими элементами и их влияние на конструктивные параметры механизма. Обоснована возможность повышения износостойкости, ресурсосбережения и создания легких конструкций с высокой прочностью. Предложенные технологические решения направлены на обеспечение надежности и долговечности конвейерной системы.

**Ключевые слова:** ленточный конвейер, роликовый механизм, элемент ленты, подшипник скольжения, трение, параметры проектирования, ресурсоэффективность, износ, рабочая поверхность, прочность.

In our republic, a number of measures are being implemented to improve the design and construction of mining, mechanical engineering, textile and light industry machinery, to conduct in-depth theoretical and experimental research on the creation of new innovative generations of machines and mechanisms, in particular, to develop new generations of highly efficient and resource-saving mechanisms for technological machines.

In a belt conveyor, guide roller mechanisms are an important functional part that performs all the functions. Depending on their technical characteristics and location, they can act as an auxiliary or main assembly of the unit. However, due to constant loads, the service life of the rollers is limited and they are regularly repaired or replaced. In order to avoid defects during the repair of a belt conveyor, it is recommended to use only original parts.

The technical task of this implementation is to further reduce the requirements for the quality of the processed parts, increase the ease of replacement and increase the service life of the roller mechanism. In addition, the task of creating a composite roller support that can be used in a belt conveyor without significant changes, and the use of

parts that act as a sliding support made of plastic and elastic elements instead of a rolling bearing that provides rotational movement of the mechanism, is considered an important innovative innovation today.

When various units and mechanisms operate, the contacting surfaces of the parts move relative to each other, which results in friction. Since the forces arising during friction are opposite to the direction of motion, they are considered destructive forces. A certain amount of energy is spent to overcome these forces, which negatively affects the efficiency of the mechanism, and the wear of the surfaces and the service life of the mechanisms change depending on the nature of the friction.

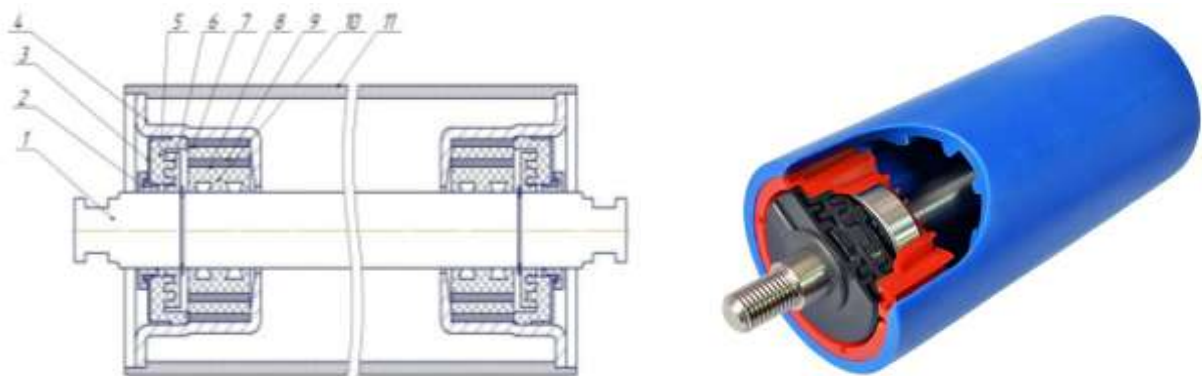

**Figure 2. Roller support (Belt conveyor)**

- 1 - shaft, 2 - labyrinth sleeve, 3 - cover, 4 - hub, 5 - labyrinth cover<sup>1</sup>, 6 - labyrinth cover<sup>2</sup>,  
7 - ring<sup>1</sup>, 8 - ring<sup>2</sup>, 9 - belt element, 10 - sliding support (graphitocaprolon), 11 - shell

In the roller device shown in the figure above, instead of a rolling bearing, we use a sliding support (10) made of plastic (graphitocaprolon) material, which provides smooth rotational movement and acts as a support. We chose this material because graphitocaprolon (10) is hard, wear-resistant, and heat-resistant.

As we know, sliding bearings have a higher coefficient of friction ( $f = 0.0015 - 0.006$ ) and a higher torque (5...10 times) than rolling bearings, so we make two

trapezoidal grooves along the circumference of the inner surface of the part made of graphite-caprolon that fits into the shaft. It goes without saying that this leads to a decrease in the coefficient of friction and torque of the part made several times [1-4].

The performance of our part when sliding relative to a shaft or axle is mainly determined by the wear pattern. That is, depending on the state of the fluid on the surface, the rubbing surfaces are separated from each other by a viscous oil layer. The most favorable condition for our part when sliding in the normal mode is friction in a liquid. When rubbing in a liquid, the surfaces are separated from each other by oil.

Two trapezoidal grooves are opened on the inner surface of the part acting as a sliding support for normal operation during sliding. A viscous liquid is applied to these trapezoidal grooves in a certain thickness. In this case, the thickness of the oil layer  $h$  – must be greater than the sum of the irregularities formed by the processing of the surfaces, that is, the following condition must be met  $h > R_{z1} + R_{z2}$  [5, 6].

Based on the above, lubricants should generally have sufficient viscosity and viscosity index; be resistant to high temperatures and have anti-corrosion properties, and be able to be driven regardless of ambient temperature and conditions [7].

In this study, modern technologies for strengthening the working surface of belt conveyor roller mechanism parts used in the mining industry were developed and their effectiveness was substantiated. The friction processes occurring in the sliding bearings with a rubber element in the roller mechanism and the influence of design parameters on wear were analyzed. The possibilities of extending the service life and ensuring reliability of the parts by increasing the strength of the working surface were shown. The proposed technological solutions serve to create resource-saving, lightweight and high-strength structures. As a result, the operational efficiency of the conveyor system increases, ensuring uninterrupted and stable operation of the production process.

## REFERENCES

- [1]. Djuraev, A., Jumaev, A.S., Ibragimova, N.I., Turdaliyeva, M.Y. Analysis of the dynamics of a belt conveyor with composite guide rollers and elastic elements. Journal of Physics: Conference Series, 2023, 2573(1), 012026.  
[https://api.scienceweb.uz/storage/publication\\_files/9737/26378/666ad94ba5c1b](https://api.scienceweb.uz/storage/publication_files/9737/26378/666ad94ba5c1b)
- [2]. Abduvaliev, U., Jumaev, A., Nurullaev, R., Ashirov, A., Abdurafikov, B. Influence of the Sectional Shape of the Grabbing Element of a Screw Composite Spindle on Agricultural Performance and Stability of Operation of a Cotton-Picking Machine. Lecture Notes in Networks and Systems, 2024, 1129.  
[https://link.springer.com/chapter/10.1007/978-3-031-70670-7\\_25](https://link.springer.com/chapter/10.1007/978-3-031-70670-7_25)
- [3]. A. Djuraev, B.N. Davidbaev, A.S. Jumaev. Improvement of the design of the belt conveyor and scientific basis for calculation of parameters. Global Book Publishing Services is an International Monograph & Textbook Publisher. Copyright 24 may 2022 by GBPS. 10.37547/gbps – 03. 1211 Polk St, Orlando, FL 32805, USA. – 151 p.
- [4]. Djuraev, A., Jumaev, A.S., Abduraxmanova, M.M. Analysis of the results of physical and mechanical experimental studies of the modernized belt conveyor. Journal of Physics: Conference Series, 2023, 2573(1), 012012.  
<https://iopscience.iop.org/article/10.1088/1742-6596/2573/1/012012>
- [5]. A. Djuraev, Sh. S. Khudaykulov, A. S. Jumaev. Development of the design and calculation of parameters of the saw cylinder with an elastic bearing support jin. International Journal of Recent Technology and Engineering (IJRTE) ISSN: 2277-3878, Volume-8 Issue-5, January 2020. <https://www.ijrte.org/portfolio-item/E6952018520/>
- [6]. Jumaev, A., Istablaev, F., Dustova, M. Development of the theory of calculation of constructive and rational parameters of belt conveyor roller mechanisms. AIP Conference Proceedings, 2022, 2467, 060025.  
[https://api.scienceweb.uz/storage/publication\\_files/9737/26397/666af69e34968](https://api.scienceweb.uz/storage/publication_files/9737/26397/666af69e34968).
- [7]. Abduvaliev, U., Jumaev, A., Nurullaev, R., Jakhonov, S., Investigation of the process of the influence of winding spindles with cotton fiber on the performance of a cotton picker. E3S Web of Conferences, 2024, 548, 04013. [https://www.e3s-conferences.org/articles/e3sconf/abs/2024/78/e3sconf\\_agritech\\_x\\_04013/e3sconf\\_agritech-x\\_04013.html](https://www.e3s-conferences.org/articles/e3sconf/abs/2024/78/e3sconf_agritech_x_04013/e3sconf_agritech-x_04013.html).

- [8]. Tilabov, B., Jumaev, A., Sherbutaev, J., Normurodov, U., Salimov, G. Testing of heat-treated surfaced samples and machine parts for hardness and wear resistance. E3S Web of Conferences, 2024, 548, 03014.  
[https://www.e3s-conferences.org/articles/e3sconf/abs/2024/78/e3sconf\\_agritech-x\\_03014/e3sconf\\_agritech-x\\_03014.html](https://www.e3s-conferences.org/articles/e3sconf/abs/2024/78/e3sconf_agritech-x_03014/e3sconf_agritech-x_03014.html)
- [9]. Jumayev A.S., Abduraxmanova M.M. Modernizatsiya qilingan tasmali konveyyer rolikli mexanizmlarining tajribaviy tadqiqot natijalari tahlili. Scientific Journal of Mechanics and Technology. ISSN 2181-158X, volume 6, Issue 1, 2025.
- [10]. Djuraev, A. Jumaev. Providing the development of new designs for the design of the roller mechanism transmitting rotational motion in belt conveyors. International Journal of Emerging Trends in Engineering Research. ISSN 2347 – 3983. Volume 8. No. 9, September 2020.
- [11]. A.S. Jumaev, A. Djuraev, M.M. Abduraxmanova. Analysis of the influence of the properties of oil products on the performance of belt conveyor guide roller mechanisms. Harvard Educational and Scientific Review International Agency for Development of Culture. Vol.2. Issue 2 Pages 44-52. 2020.
- [12]. A.S. Jumaev, A. Djuraev, A.N. Pushanov. Development of models of recession of defatory states of components as a result of external loads of belt conveyor drums. Harvard Educational and Scientific Review International Agency for Development of Culture. Vol.2. Issue 2 Pages 36-43. 2020.
- [13]. A.D. Djuraev, A.S. Jumaev. Study the influence of parameters of elastic coupling on the movement nature of support roller and rocker arm crank-beam mechanism. International Journal of Advanced Research in Science, Engineering and Technology Vol. 6, Issue 6, June 2019.
- [14]. A.S. Jumayev. Tasmali konveyyer rolikli mexanizmlarini resurstejamkor konstruksiyalarini ishlab chiqish va nazariy tahlil qilish. Scientific journal of mechanics and technology ISSN 2181-158X, volume 5, Issue 1, 2024.

## **TECHNOLOGY AND CONSTRUCTION FEATURES OF MEN'S TROUSER SEWING**

*Mendiboyeva Azizaxon Sotvoldiyevna*

*Technical College No. 1, Buloqboshi District,*

*Andijan Region*

### **Abstract**

This scientific article analyzes the design, pattern construction, and sewing process of men's trousers based on a scientific and technological approach. The study examines pattern development based on anthropometric measurements, fabric selection criteria, the main structural elements of trousers, the technological sequence of sewing operations, and quality control requirements. Furthermore, the role of ergonomic comfort, aesthetic appearance, and modern manufacturing technologies in trousers production is discussed.

**Keywords:** men's clothing, trousers, construction, pattern making, fabric, sewing technology, waistband, pocket, quality control, ergonomics.

## **ERKAKLAR SHIMINI TIKISH TEXNOLOGIYASI VA KONSTRUKTSION XUSUSIYATLARI**

*Mendiboyeva Azizaxon Sotvoldiyevna*

*Andijon viloyati Buloqboshi tumani 1- son tehnikumi*

### **Annotatsiya**

Mazkur ilmiy maqolada erkaklar shimini loyihalash, konstruktsiyalash va tikish jarayonlari ilmiy-texnologik yondashuv asosida tahlil qilinadi. Antropometrik

o'lchamlar asosida andoza tuzish, gazlama tanlash mezonlari, shim konstruktsiyasining asosiy elementlari, tikuv jarayonining texnologik ketma-ketligi hamda sifat nazorati talablari yoritiladi. Shuningdek, ergonomik qulaylik, estetik ko'rinish va zamonaviy ishlab chiqarish texnologiyalarining roli ko'rib chiqiladi.

**Kalit so'zlar:** erkaklar kiyimi, shim, konstruktsiya, andoza, gazlama, tikuv texnologiyasi, kamar, cho'ntak, sifat nazorati, ergonomika.

### **Kirish**

Yengil sanoatda erkaklar kiyimlari ishlab chiqarish muhim yo'nalishlardan biri bo'lib, shim (bryuk) erkaklar garderobining asosiy elementlaridan hisoblanadi. Erkaklar shimiga qo'yiladigan talablar — qulaylik, mustahkamlik, estetik ko'rinish va o'lcham aniqligidir.

Zamonaviy ishlab chiqarishda shim konstruktsiyasini to'g'ri ishlab chiqish, sifatli gazlama tanlash va ilg'or tikuv texnologiyalarini qo'llash mahsulotning raqobatbardoshligini ta'minlaydi. Shu sababli shim tikish jarayonini ilmiy asosda tashkil etish dolzarb masala hisoblanadi.

### **Adabiyotlar tahlili**

Kiyim konstruktsiyasi bo'yicha olib borilgan tadqiqotlarda erkaklar shimining ergonomik mosligi va konstruktsion aniqligi alohida ta'kidlangan. Cooklin (2017) shim konstruktsiyasida o'tirish qulayligi va qadam kengligi muhim parametr ekanini ko'rsatadi. Armstrong (2018) esa andoza tuzishda antropometrik o'lchamlarning aniqligi mahsulot sifatiga bevosita ta'sir qilishini qayd etadi.

So‘nggi tadqiqotlarda avtomatlashtirilgan bichish va CAD tizimlarining qo‘llanilishi ishlab chiqarish samaradorligini oshirishi isbotlangan.

## **Asosiy qism**

### **1. Antropometrik o‘lchamlar**

Erkaklar shimini loyihalashda quyidagi asosiy o‘lchamlar olinadi:

- Bel aylana uzunligi
- Son aylana uzunligi
- O‘tirish balandligi
- Shim uzunligi
- Tizza kengligi
- Pastki kenglik

Bu o‘lchamlar shimning tana tuzilishiga mos tushishini ta’minlaydi.

### **2. Konstruksiya va andoza tuzish**

Erkaklar shimining asosiy qismlari:

- Old bo‘lak
- Orqa bo‘lak
- Kamar
- Yon cho‘ntaklar
- Orqa cho‘ntak
- Pacha (pastki qism)
- Fermuar qismi

Andoza tuzishda harakat erkinligi uchun zarur qo‘shimchalar hisobga olinadi. Klassik shimlarda siluet to‘g‘ri yoki biroz torayuvchi bo‘ladi.

### **3. Gazlama tanlash mezonlari**

Erkaklar shimlari uchun quyidagi gazlamalar keng qo'llaniladi:

- Kostyumlik matolar
- Gabardin
- Twill
- Paxta aralash matolar
- Stretch qo'shimchali matolar

Gazlama tanlashda quyidagilar muhim:

- Mustahkamlik
- G'ijimlanmaslik
- Shaklni saqlash
- Havo o'tkazuvchanlik

### **4. Tikuv texnologiyasi jarayoni**

Shim tikish jarayoni quyidagi bosqichlarda amalga oshiriladi:

1. Gazlamani tayyorlash
2. Andoza asosida bichish
3. Cho'ntaklarni tayyorlash
4. Old va orqa bo'laklarni biriktirish
5. O'rta chokni tikish
6. Fermuar o'rnatish
7. Kamarni tikish
8. Pastki qismni qayirish
9. Yakuniy dazmollash

Sanoat tikuv mashinalari va maxsus press uskunalari sifatni oshiradi.

## **5. Sifat nazorati**

Mahsulot sifati quyidagi mezonlar asosida baholanadi:

- O'lcham aniqligi
- Choklarning mustahkamligi
- Cho'ntak va fermuar sifati
- Simmetriya
- Estetik ko'rinish
- 

## **Xulosa**

Erkaklar shimini tikish jarayoni yuqori darajadagi konstruksion aniqlik, sifatli material tanlovi hamda zamonaviy texnologik yechimlarning uyg'un qo'llanilishini talab etadi. Mahsulotni loyihalash bosqichida antropometrik o'lchamlarning to'g'ri aniqlanishi va ular asosida andoza ishlab chiqilishi shimning tana tuzilishiga mos tushishini, harakat erkinligini va umumiy ergonomik qulayligini ta'minlaydi. Ayniqsa, o'tirish balandligi, son kengligi va qadam (shag) qismi parametrlarini ilmiy asosda hisoblash mahsulotning funksional sifatiga bevosita ta'sir ko'rsatadi.

Sifatli gazlama tanlash ham shimning ekspluatatsion ko'rsatkichlarini belgilovchi muhim omillardan biridir. Gazlamaning mustahkamligi, g'ijimlanishga chidamliligi, shaklni saqlash qobiliyati va gigiyenik xususiyatlari mahsulotning uzoq muddat xizmat qilishini ta'minlaydi. Cho'ntaklar, fermuar qismi va kamar konstruksiyasining texnologik jihatdan to'g'ri bajarilishi esa shimning tashqi ko'rinishi va foydalanish qulayligini oshiradi.

Zamonaviy tikuv uskunalari va sanoat texnologiyalaridan foydalanish ishlab chiqarish samaradorligini oshiradi, mehnat unumdorligini yaxshilaydi hamda sifatning barqarorligini ta'minlaydi. Ayniqsa, avtomatlashtirilgan bichish tizimlari material sarfini optimallashtirish, inson omili ta'sirini kamaytirish va ishlab chiqarish tezligini oshirishda muhim ahamiyat kasb etadi.

Kelajakda 3D modelirovka, virtual fitting, CAD/CAM tizimlari va raqamli ishlab chiqarish platformalarining keng joriy etilishi erkaklar shimlari dizayni va ishlab chiqarish jarayonini yanada takomillashtirishi kutilmoqda. Ushbu innovatsiyalar individual buyurtmalarni tezkor bajarish, mahsulotni oldindan vizuallashtirish va konstruktiv xatoliklarni kamaytirish imkonini beradi.

Shuningdek, ekologik barqarorlik tamoyillarini joriy etish, qayta ishlanadigan va energiya tejankor materiallardan foydalanish yengil sanoat rivojining ustuvor yo'nalishlaridan biri bo'lib qoladi. Ilmiy asoslangan konstruktsiya, innovatsion texnologiyalar va kompleks sifat nazorati tizimining uyg'unligi erkaklar shimlari ishlab chiqarishning raqobatbardoshligini ta'minlaydi hamda sohaning barqaror rivojlanishiga xizmat qiladi.

#### **Foydalanilgan adabiyotlar**

1. Cooklin G. Garment Technology for Fashion Designers. Oxford, 2017.
2. Armstrong J. Patternmaking for Fashion Design. New York, 2018.
3. Karimova M. Tikuvchilik texnologiyasi asoslari. Toshkent, 2019.
4. Smith A. Fashion Design Technology. London, 2020.

## **TECHNOLOGY AND CONSTRUCTION FEATURES OF MEN'S SHIRT SEWING**

*Fergana Region, Uzbekistan District Technical College No. 1*

*Shakirova Mahmuda Sharibjonovna*

### **Abstract**

This scientific article analyzes the design, pattern construction, and sewing process of men's shirts (classic men's dress shirts) based on a scientific and technological approach. The study examines pattern development based on anthropometric measurements, fabric selection criteria, collar and cuff construction, the technological sequence of sewing operations, and quality control requirements. Furthermore, the role of ergonomic fit, aesthetic appearance, and modern manufacturing technologies in shirt production is discussed.

**Keywords:** men's clothing, shirt, construction, pattern making, fabric, collar, cuff, sewing technology, quality control, ergonomics.

## **ERKAKLAR SARO'CHKASINI TIKISH TEXNOLOGIYASI VA KONSTRUKTSION XUSUSIYATLARI**

*Farg'ona viloyati O'zbekiston tuman 1-son tehnikumi*

*Shakirova Mahmuda Sharibjonovna*

### **Annotatsiya**

Mazkur ilmiy maqolada erkaklar saro'chkasini (klassik erkaklar ko'ylagi) loyihalash, konstruksiyalash va tikish jarayonlari ilmiy-texnologik yondashuv asosida tahlil qilinadi. Antropometrik o'lchamlar asosida andoza tuzish, gazlama tanlash mezonlari, yoqa va manjet konstruksiyasi, tikuv jarayonining texnologik ketma-ketligi

hamda sifat nazorati talablari yoritiladi. Shuningdek, ergonomik moslik, estetik ko‘rinish va zamonaviy ishlab chiqarish texnologiyalarining roli ko‘rib chiqiladi.

**Kalit so‘zlar:** erkaklar kiyimi, saro‘chka, konstruktsiya, andoza, gazlama, yoqa, manjet, tikuv texnologiyasi, sifat nazorati, ergonomika.

## **Kirish**

Yengil sanoat tarmog‘ida erkaklar kiyimlari, xususan saro‘chka (klassik erkaklar ko‘ylagi) ishlab chiqarish muhim yo‘nalishlardan biri hisoblanadi. Erkaklar saro‘chkasi rasmiy, ishbilarmonlik va kundalik kiyim sifatida keng qo‘llaniladi.

Saro‘chka konstruktsiyasi aniqlik, simmetriya va minimalistik dizayn bilan ajralib turadi. Mahsulotni loyihalashda antropometrik o‘lchamlar, harakat erkinligi va estetik muvozanat muhim ahamiyat kasb etadi. Zamonaviy ishlab chiqarish jarayonida avtomatlashtirilgan bichish tizimlari va sanoat tikuv mashinalari keng qo‘llanilmoqda.

## **Adabiyotlar tahlili**

Ilmiy manbalarda erkaklar kiyim konstruktsiyasi, ayniqsa klassik ko‘ylakning yoqa va manjet qismlarini ishlab chiqish texnologiyasi alohida o‘rganilgan. Armstrong (2018) erkaklar kiyimida simmetriya va konstruktiv aniqlik asosiy mezon ekanligini ta’kidlaydi. Cooklin (2017) esa erkaklar ko‘ylagida chok mustahkamligi va material sifatining uzoq muddatli ekspluatatsiyaga ta’sirini tahlil qiladi.

Tadqiqotlar shuni ko‘rsatadiki, erkaklar saro‘chkasida konstruktiv minimalizm va funksionallik ustuvor ahamiyatga ega.

## **Asosiy qism**

## **1. Antropometrik o'lchamlar**

Erkaklar saro'chkasini loyihalashda quyidagi asosiy o'lchamlar olinadi:

- Ko'krak aylana uzunligi
- Bel aylana uzunligi
- Bo'yin aylana uzunligi
- Yelka kengligi
- Yeng uzunligi
- Orqa uzunligi

Bo'yin aylana o'lchami yoqa konstruktsiyasi uchun asosiy parametr hisoblanadi.

## **2. Konstruktsiya va andoza tuzish**

Saro'chka quyidagi asosiy qismlardan iborat:

- Old bo'lak (plankali yoki knopkali)
- Orqa bo'lak (yuklama yoki buklama bilan)
- Yeng
- Yoqa (stoykali yoki klassik qayrilma)
- Manjet
- Ko'krak cho'ntagi (ixtiyoriy)

Andoza tuzishda erkinlik qo'shimchalari hisobga olinadi. Erkaklar kiyimida odatda 4–8 sm erkinlik qo'shimchasi qo'llaniladi.

## **3. Gazlama tanlash**

Erkaklar saro'chkalari uchun quyidagi gazlamalar keng qo'llaniladi:

201

- Paxta (100%)
- Paxta + poliester aralashmasi
- Oksford matosi
- Poplin
- Satin to‘qima

Gazlama tanlashda havo o‘tkazuvchanlik, namlikni shimish xususiyati va mustahkamlik asosiy mezon hisoblanadi.

#### **4. Tikuv texnologiyasi**

Saro‘chka tikish jarayoni quyidagi ketma-ketlikda amalga oshiriladi:

1. Gazlamani tayyorlash (bug‘lash)
2. Bichish
3. Yelka choklarini biriktirish
4. Yoqa va yoqa stoykasini tikish
5. Yeng o‘rnatish
6. Yon choklarni tikish
7. Manjet o‘rnatish
8. Tugma va ilgaklarni tikish
9. Yakuniy dazmollash

Yoqa va manjet qismlarida mustahkamlovchi (dublerin) material qo‘llaniladi.

#### **5. Sifat nazorati**

Mahsulot sifati quyidagi mezonlar asosida baholanadi:

- Yoqa va manjet simmetriyasi
- Choklarning to'g'riligi va mustahkamligi
- Tugmalarning tekis joylashuvi
- O'lcham aniqligi
- Estetik ko'rinish

Sifat nazorati ishlab chiqarishning har bir bosqichida amalga oshiriladi.

### **Xulosa**

Erkaklar saro'chkasini tikish jarayoni yuqori darajadagi aniqlik, konstruktiv muvozanat hamda texnologik intizomni talab etadi. Mahsulotning sifat ko'rsatkichlari, avvalo, antropometrik o'lchamlarning to'g'ri aniqlanishi va ular asosida andoza tuzilishiga bog'liq. Konstruktsiya jarayonida proporsiya, simmetriya va harakat erkinligini ta'minlovchi erkinlik qo'shimchalari ilmiy asosda hisoblanishi lozim. Bu esa tayyor mahsulotning ergonomik qulayligini va tana tuzilishiga mosligini ta'minlaydi.

Sifatli gazlama tanlash ham muhim omillardan biri bo'lib, uning gigiyenik xususiyatlari, mustahkamligi va shaklni saqlash qobiliyati mahsulotning ekspluatatsion muddatiga bevosita ta'sir ko'rsatadi. Yoqa va manjet qismlarida mustahkamlovchi materiallardan foydalanish, choklarning aniqligi va tugma joylashuvining simmetriyasi erkaklar saro'chkasining estetik ko'rinishini belgilovchi asosiy mezonlar hisoblanadi.

Zamonaviy tikuv texnologiyalari va sanoat uskunalaridan foydalanish ishlab chiqarish samaradorligini oshiradi, mehnat unumdorligini yaxshilaydi hamda mahsulot sifatining barqarorligini ta'minlaydi. Ayniqsa, avtomatlashtirilgan bichish tizimlari material sarfini optimallashtiradi va chiqindilarni kamaytiradi.

Kelajakda 3D modelirovka, virtual fitting texnologiyalari, raqamli andoza yaratish tizimlari (CAD/CAM) va aqlli ishlab chiqarish (smart manufacturing) konsepsiyalari erkaklar kiyimlari ishlab chiqarish jarayonini yanada takomillashtirishi kutilmoqda. Ushbu innovatsiyalar mahsulot dizaynini tezkor ishlab chiqish, individual buyurtmalarni samarali bajarish va bozor talabiga moslashuvchanlikni oshirish imkonini beradi.

Shuningdek, barqaror ishlab chiqarish tamoyillarini joriy etish, ekologik toza materiallardan foydalanish va energiya tejamkor texnologiyalarni qo'llash yengil sanoatning istiqbolli rivojlanish yo'nalishlaridan biri bo'lib qoladi. Ilmiy asoslangan konstruktsiya, innovatsion texnologiyalar va sifat nazoratining uzluksiz tizimi erkaklar saro'chkasi ishlab chiqarishning raqobatbardoshligini ta'minlaydi.

### **Foydalanilgan adabiyotlar**

1. Armstrong J. Patternmaking for Fashion Design. New York: Fairchild Books, 2018.
2. Cooklin G. Garment Technology for Fashion Designers. Oxford: Blackwell Science, 2017.
3. Karimova M. Tikuvchilik texnologiyasi asoslari. Toshkent: O'qituvchi, 2019.
4. Smith A. Fashion Design Technology. London: Textile Press, 2020.

## **TECHNOLOGY AND DESIGN FEATURES OF SEWING MODERN WOMEN'S DRESSES**

*Soliyeva Odinaxon To'lanboy qizi*

*Andijan Region, Shahrison District Vocational School No. 4, Industrial Training*

*Instructor*

### **Abstract**

This scientific article provides a comprehensive analysis of the design, pattern construction, and sewing process of modern women's dresses based on a scientific and technological approach. The study examines the impact of fashion trends on the development of the light industry, hygienic and performance criteria for fabric selection, stages of pattern making based on anthropometric measurements, the technological sequence of sewing processes, and quality control standards. Furthermore, the integration of ergonomic principles and aesthetic requirements is considered as a key factor in the production of modern women's garments.

**Keywords:** modern fashion, women's clothing, construction, pattern making, fabric, sewing technology, ergonomics, anthropometry, quality control.

## **AYOLLAR ZAMONAVIY KO'YLAGINI TIKISH TEXNOLOGIYASI VA DIZAYN XUSUSIYATLARI**

*Soliyeva Odinaxon To'lanboy qizi*

*Andijon viloyati Shahrison tumani*

*4-son texnokumi ishlab chiqarish ta'limi ustasi*

**Annotatsiya.** Mazkur ilmiy maqolada ayollar zamonaviy ko'ylagini loyihalash, konstruksiyalash va tikish jarayonlari ilmiy-texnologik yondashuv asosida batafsil

tahlil qilinadi. Moda tendensiyalarining yengil sanoat rivojiga ta'siri, gazlama tanlashning gigiyenik va ekspluatatsion mezonlari, antropometrik o'lchamlar asosida andoza tuzish bosqichlari, tikuv jarayonining texnologik ketma-ketligi hamda sifat nazorati mezonlari ilmiy asosda yoritiladi. Shuningdek, ergonomika va estetik talablarning uyg'unligi zamonaviy ko'ylak ishlab chiqarishdagi asosiy omil sifatida ko'rib chiqiladi.

**Kalit so'zlar:** zamonaviy moda, ayollar kiyimi, konstruktsiya, andoza, gazlama, tikuv texnologiyasi, ergonomika, antropometriya, sifat nazorati.

**Kirish.** Yengil sanoat O'zbekiston iqtisodiyotida strategik ahamiyatga ega bo'lgan tarmoqlardan biridir. Ayniqsa, ayollar kiyimlari ishlab chiqarish bozor talabining yuqoriligi va moda tendensiyalarining tez o'zgaruvchanligi sababli doimiy ravishda takomillashib boradi.

Zamonaviy ayollar ko'ylagi nafaqat estetik ko'rinishga ega bo'lishi, balki funksional, ergonomik va gigiyenik talablarni ham qondirishi zarur. Kiyim insonning tashqi qiyofasini shakllantiruvchi muhim omil bo'lib, uning ijtimoiy mavqeini ham ifodalaydi. Shu sababli ko'ylakni loyihalash jarayoni ilmiy asoslangan konstruktsiya va texnologik yondashuvni talab qiladi.

Bugungi kunda ishlab chiqarish jarayonlarida raqamli dizayn tizimlari (CAD), avtomatlashtirilgan bichish uskunalari va zamonaviy tikuv mashinalaridan foydalanish mahsulot sifatini oshirishga xizmat qilmoqda.

**Adabiyotlar tahlili.** Ilmiy manbalarda kiyim konstruktsiyasi va moda dizayni bo'yicha ko'plab tadqiqotlar olib borilgan. Armstrong (2018) kiyim konstruktsiyasini tana antropometriyasi asosida ishlab chiqish zarurligini ta'kidlaydi. Karimova (2019) esa

tikuvchilik texnologiyasida chok turlari va gazlama xususiyatlarining mahsulot sifatiga ta'sirini ilmiy asosda tahlil qilgan.

Zamonaviy tadqiqotlarda barqaror moda (sustainable fashion) konsepsiyasi ham keng yoritilmoqda. Ekologik toza va qayta ishlanadigan materiallardan foydalanish global moda sanoatining ustuvor yo'nalishlaridan biri hisoblanadi.

Ergonomika sohasidagi tadqiqotlar kiyimning inson harakatiga moslashuvchanligini ta'minlash muhimligini ko'rsatadi. Antropometrik o'lchamlarning to'g'ri olinishi konstruktsiya aniqligini belgilaydi.

## **Asosiy qism**

### **1. Zamonaviy dizayn tendensiyalari**

Zamonaviy ayollar ko'ylaklarida quyidagi dizayn xususiyatlari kuzatiladi:

- Minimalistik shakllar va toza chiziqlar
- A-siluet va oversize modellari
- Tabiiy ranglar va pastel gammasi
- Ekologik gazlamalar
- Ko'p funktsionallik (kundalik + ofis uslubi)

Dizayn jarayonida moda tendensiyalarini tahlil qilish, maqsadli auditoriyani aniqlash va bozordagi talabni o'rganish muhim bosqich hisoblanadi.

### **2. Antropometrik o'lchamlar va andoza tuzish**

Ko'ylak konstruktsiyasi quyidagi asosiy o'lchamlar asosida ishlab chiqiladi:

- Ko'krak aylana uzunligi
- Bel aylana uzunligi
- Son aylana uzunligi
- Yelka kengligi
- Yeng uzunligi
- Umumiy uzunlik

Andoza tuzishda erkinlik qo'shimchalari (pripusk) hisobga olinadi. Zamonaviy ishlab chiqarishda CAD tizimlari yordamida andozalar aniq va tezkor tuziladi.

Konstruktsiya jarayonida simmetriya, proporsiya va siluet muvozanati muhim ahamiyat kasb etadi.

### **3. Gazlama tanlash mezonlari**

Gazlama tanlashda quyidagi omillar inobatga olinadi:

- Gigiyenik xususiyatlar (havo o'tkazuvchanlik)
- Mustahkamlik
- Shaklni saqlash qobiliyati
- Elastiklik
- Parvarish qulayligi

Paxta, zig'ir, viskoza va aralash tolali matolar keng qo'llaniladi. Tabiiy tolalar organizm uchun qulay va ekologik jihatdan xavfsiz hisoblanadi.

### **4. Tikuv texnologiyasi jarayoni**

Tikuv jarayoni quyidagi bosqichlardan iborat:

1. Gazlamani tayyorlash (bug‘lash va tekislash)
2. Andoza asosida bichish
3. Yelka va yon choklarni biriktirish
4. Yeng o‘rnatish
5. Yoqa va bezak elementlarini tikish
6. Pastki qismni qayirish
7. Yakuniy dazmollash

Sanoat tikuv mashinalari (tekis chok, overlok, yashirin chok mashinalari) mahsulot sifatini oshiradi va ishlab chiqarish samaradorligini ta’minlaydi.

## **5. Sifat nazorati**

Mahsulot sifati quyidagi mezonlar asosida baholanadi:

- Choklarning mustahkamligi
- O‘lcham aniqligi
- Simmetriya
- Estetik ko‘rinish
- Nuqsonlarning yo‘qligi

Sifat nazorati ishlab chiqarish jarayonining barcha bosqichlarida amalga oshiriladi.

**Xulosa.** Ayollar zamonaviy ko‘ylagini tikish jarayoni ilmiy asoslangan konstruktsiya, ergonomik yondashuv hamda zamonaviy texnologik vositalarni qo‘llashni talab qiladi. Mahsulotni loyihalash jarayonida antropometrik o‘lchamlarning aniqligi, andoza tuzishdagi konstruktsion muvozanat va gazlama xususiyatlarini chuqur tahlil qilish muhim ahamiyat kasb etadi. Bu omillar tayyor mahsulotning estetik ko‘rinishi, qulayligi va ekspluatatsion mustahkamligini ta’minlaydi.

Moda tendensiyalari va iste'molchilar ehtiyojlarini inobatga olgan holda ishlab chiqarilgan ko'ylaklar nafaqat bozor talabiga javob beradi, balki raqobatbardoshlikni ham oshiradi. Zamonaviy dizayn va texnologiyalar uyg'unligi mahsulotning funksionalligi, gigiyenikligi hamda uzoq muddatli foydalanish imkoniyatlarini kengaytiradi.

Kelajakda raqamli dizayn tizimlari (CAD), 3D modelirovka, virtual fitting (raqamli kiyib ko'rish) texnologiyalari hamda avtomatlashtirilgan tikuv komplekslari ishlab chiqarish jarayonini yanada optimallashtiradi. Bu esa mehnat unumdorligini oshirish, material sarfini kamaytirish va mahsulot sifatini barqaror nazorat qilish imkonini beradi.

Shuningdek, barqaror moda (sustainable fashion) tamoyillarini joriy etish, ekologik toza va qayta ishlanadigan materiallardan foydalanish yengil sanoatning istiqbolli yo'nalishlaridan biri hisoblanadi. Ilmiy asoslangan yondashuv, innovatsion texnologiyalar va dizayn yechimlarining integratsiyasi ayollar kiyimlari ishlab chiqarish sohasining barqaror rivojlanishiga xizmat qiladi.

### **Foydalanilgan adabiyotlar**

1. Armstrong J. Patternmaking for Fashion Design. New York: Fairchild Books, 2018.
2. Karimova M. Tikuvchilik texnologiyasi asoslari. Toshkent: O'qituvchi, 2019.
3. Smith A. Fashion Design Technology. London: Textile Press, 2020.
4. Cooklin G. Garment Technology for Fashion Designers. Oxford: Blackwell Science, 2017.

## **TECHNOLOGY AND ARTISTIC-CONSTRUCTION FEATURES OF SEWING WOMEN'S NATIONAL DRESSES**

*Fergana Region, Uzbekistan Technical College No. 2*

*Nazirova Olmaxon Isomiddinovna*

### **Abstract**

This scientific article analyzes the design, pattern construction, and sewing process of women's national dresses based on a scientific and technological approach. The study examines the historical development of national garments, decorative elements, fabric selection criteria, stages of pattern making based on anthropometric measurements, and the technological sequence of sewing operations. Furthermore, the integration of aesthetic, symbolic, and cultural factors in national dress production, as well as the role of modern manufacturing technologies, is discussed.

**Keywords:** national costume, women's dress, atlas fabric, adras fabric, construction, pattern making, decoration, embroidery, sewing technology, cultural heritage.

## **AYOLLAR MILLIY KO'YLAGINI TIKISH TEXNOLOGIYASI VA BADIY-KONSTRUKTSION XUSUSIYATLARI**

*Farg'ona viloyati O'zbekiston 2-son tehnikumi*

*Nazirova Olmaxon Isomiddinovna*

### **Annotatsiya**

Mazkur ilmiy maqolada ayollar milliy ko'ylagini loyihalash, konstruksiyalash va tikish jarayonlari ilmiy-texnologik yondashuv asosida tahlil qilinadi. Milliy kiyimlarning tarixiy shakllanishi, bezak elementlari, gazlama tanlash mezonlari, antropometrik o'lchamlar asosida andoza tuzish bosqichlari hamda tikuv texnologiyasining ketma-ketligi yoritiladi. Shuningdek, milliy ko'ylaklarda estetik,

ramziy va madaniy omillarning uyg'unligi hamda zamonaviy ishlab chiqarish texnologiyalarining roli ko'rib chiqiladi.

**Kalit so'zlar:** milliy kiyim, ayollar ko'ylagi, atlas, adras, konstruktsiya, andoza, bezak, kashtachilik, tikuv texnologiyasi, madaniy meros.

## **Kirish**

O'zbek xalqining milliy kiyimlari asrlar davomida shakllangan madaniy merosning ajralmas qismi hisoblanadi. Ayollar milliy ko'ylagi o'zining rang-barangligi, bezaklari va o'ziga xos silueti bilan ajralib turadi.

Milliy ko'ylak nafaqat kiyim, balki xalqning estetik qarashlari, urf-odatlari va ijtimoiy mavqeini ifodalovchi madaniy ramzdir. Zamonaviy sharoitda milliy ko'ylaklar an'anaviy uslubni saqlagan holda yangi dizayn va texnologiyalar bilan boyitilmoqda.

## **Adabiyotlar tahlili**

Ilmiy tadqiqotlarda milliy kiyimlarning tarixiy taraqqiyoti, mato va bezak turlari, kashtachilik san'ati keng o'rganilgan. Atlas va adras gazlamalarining to'qilish texnologiyasi hamda ularning estetik xususiyatlari milliy ko'ylak dizaynida muhim o'rin tutadi.

Tadqiqotlar shuni ko'rsatadiki, milliy kiyim konstruktsiyasi oddiy shaklda bo'lsa-da, bezak elementlari orqali badiiy boylikka ega bo'ladi. Zamonaviy dizayn yondashuvi esa milliy elementlarni global moda bilan uyg'unlashtirishga xizmat qiladi.

## **Asosiy qism**

### **1. Milliy ko'ylakning konstruktsion xususiyatlari**

Ayollar milliy ko‘ylagi odatda quyidagi qismlardan iborat:

- Old va orqa bo‘lak
- Keng yeng
- Yoqa (oddiy yoki bezakli)
- Etak qismi (kengaytirilgan)

Milliy ko‘ylaklarda siluet keng va erkin bo‘lib, harakat qulayligini ta’minlaydi.

## **2. Gazlama va bezak elementlari**

Milliy ko‘ylaklar uchun asosan quyidagi gazlamalar ishlatiladi:

- Atlas
- Adras
- Ipak
- Baxmal

Bezak elementlari:

- Qo‘l kashtachiligi
- Zar ip bilan bezash
- To‘r va bant elementlari
- Milliy naqshlar

Rang tanlashda milliy ramziylik va hududiy an’analar inobatga olinadi.

## **3. Antropometrik o‘lchamlar va andoza**

Milliy ko‘ylak konstruksiyasida quyidagi o‘lchamlar olinadi:

- Ko'krak aylana uzunligi
- Bel aylana uzunligi
- Son aylana uzunligi
- Yeng uzunligi
- Umumiy uzunlik

Erkinlik qo'shimchalari kengroq qo'llaniladi, chunki milliy ko'ylaklar odatda keng fasonli bo'ladi.

#### **4. Tikuv texnologiyasi**

Milliy ko'ylak tikish jarayoni:

1. Gazlamani tayyorlash
2. Andoza asosida bichish
3. Asosiy choklarni biriktirish
4. Yeng o'rnatish
5. Bezak elementlarini tikish yoki kashta qilish
6. Yakuniy ishlov va dazmollash

Qo'l mehnati va kashtachilik san'ati milliy ko'ylak ishlab chiqarishda muhim o'rin tutadi.

---

#### **5. Sifat nazorati**

Sifat nazorati quyidagi mezonlarga asoslanadi:

- Naqsh simmetriyasi

- Bezak elementlarining mustahkamligi
- Choklarning to'g'riligi
- Gazlama sifatining saqlanishi
- Estetik ko'rinish

### **Xulosa**

Ayollar milliy ko'ylagini tikish jarayoni an'anaviy san'at va zamonaviy texnologiyalarning uyg'unligini talab etadi. Milliy kiyim konstruksiyasi, odatda, soddaligi bilan ajralib tursa-da, uning badiiy qiymati bezak elementlari, rang uyg'unligi va naqshlarning ramziy ma'nosi orqali namoyon bo'ladi. Shu bois milliy ko'ylakni loyihalash jarayonida nafaqat texnologik aniqlik, balki estetik did, tarixiy meros va madaniy an'analarni chuqur bilish ham muhim ahamiyat kasb etadi.

Antropometrik o'lchamlar asosida tuzilgan andoza milliy ko'ylakning ergonomik qulayligini ta'minlaydi, keng siluet va erkin fason esa harakat erkinligini oshiradi. Gazlama tanlashda atlas, adras, ipak va baxmal kabi an'anaviy matolarning sifat ko'rsatkichlari, mustahkamligi va estetik jozibadorligi alohida e'tiborga olinadi. Bezak elementlari – kashtachilik, zar ip bilan ishlov berish, milliy naqshlar – mahsulotning madaniy qiymatini oshiradi va uni boshqa kiyim turlaridan ajratib turadi.

Zamonaviy ishlab chiqarish jarayonlarida raqamli dizayn tizimlari (CAD), 3D modelirovka va avtomatlashtirilgan bichish uskunalarining qo'llanilishi milliy kiyimlarni sifatli va tezkor ishlab chiqarish imkonini yaratadi. Virtual modelirovka texnologiyalari dizaynni oldindan ko'rish, xatoliklarni kamaytirish va material sarfini optimallashtirishga yordam beradi. Bu esa ishlab chiqarish samaradorligini oshiradi va raqobatbardoshlikni ta'minlaydi.

Kelajakda milliy kiyimlarni zamonaviy moda tendensiyalari bilan uyg'unlashtirish, ekologik toza materiallardan foydalanish va barqaror ishlab chiqarish tamoyillarini joriy

etish yengil sanoat rivojining muhim yo‘nalishlaridan biri bo‘lib qoladi. Milliy merosni asrab-avaylash, uni innovatsion texnologiyalar asosida qayta talqin qilish hamda yosh avlodga yetkazish madaniy va iqtisodiy jihatdan muhim vazifa hisoblanadi. Shu tariqa, ayollar milliy ko‘ylagini ilmiy asosda ishlab chiqish va zamonaviylashtirish milliy identitetni saqlash bilan birga, global moda maydonida ham munosib o‘rin egallash imkonini beradi.

### **Foydalanilgan adabiyotlar**

1. Karimova M. Tikuvchilik texnologiyasi asoslari. Toshkent, 2019.
2. O‘zbek milliy kiyimlari tarixi. Toshkent, 2015.
3. Cooklin G. Garment Technology for Fashion Designers. Oxford, 2017.
4. Smith A. Fashion Design Technology. London, 2020.

## HOSPITALITY AND TOURISM IN CHINA

Nabijonova Shohida

Tashkent State University of Oriental Studies 1<sup>st</sup> level Student of Master's Degree

**Abstract.** This article explores the rapid development of hospitality and tourism in the Republic of China. As one the world's largest tourism markets, China has become a global leader in domestic travel, cultural heritage tourism, and hospitality services. The study examines China's diverse tourism resources, the growth of the hotel and restaurant industry, the sector's economic contributions, challenges such as sustainability and over-tourism, and the government's strategic policies. It concludes with insights into the role of digitalization and sustainable practices in shaping the future of Chinese hospitality and tourism.

**Keywords:** China, hospitality industry, tourism development, cultural heritage, domestic tourism, sustainable tourism, hotel sector, ecotourism.

**摘要:**本文探讨了中华人民共和国酒店业和旅游业的快速发展。作为世界上最大的旅游市场之一，中国已成为国内旅游、文化遗产旅游和酒店服务的全球领导者。研究考察了中国多样化的旅游资源、酒店和餐饮业的增长、该行业的经济贡献、可持续性和过度旅游等挑战，以及政府的战略政策。文章最后对数字化和可持续实践在塑造中国酒店业和旅游业未来中的作用进行了分析。

**关键词:** 中国，酒店业，旅游发展，文化遗产，国内旅游，可持续旅游，酒店行业，生态旅游

**Introduction.** China has emerged as one of the most dynamic players in the global hospitality and tourism sector. Before the COVID-19 pandemic, the country ranked among the world's top five tourist destinations, with over 65.7 million international arrivals in 2019 (UNWTO,2020). At the same time, domestic tourism

reached more than 6 billion trips annually, making China the largest domestic tourism market worldwide. The hospitality industry- encompassing hotels, resorts, restaurants, and related services- has expanded rapidly to meet the needs of both domestic and international travelers. Tourism and hospitality now account for over 11% of China's GDP, creating millions of jobs and supporting regional development.

**Tourism Resources in China.** Cultural heritage. China's long history and civilization provide a foundation for its tourism industry. With 56 UNESCO WORLD Heritage Sites (as of 2024), the country is globally recognized for its cultural and historical landmarks. The Great Wall, Forbidden City, and Terracotta warriors attract millions of visitors each year. In addition, traditional festivals such as the Chinese New Year and Dragon Boat Festival are central to cultural tourism.

Natural attractions. China's diverse geography- from the Himalayas and the Yangtze River to tropical Hainan Island- makes it a leading nature tourism destination. National parks like Zhangjiajie, which inspired the floating mountains in the film Avatar, and Jiuzhaigou Valley are globally renowned. Ecotourism is increasingly promoted to balance economic growth with environmental sustainability.

**The hospitality industry in China.** Hotel Sector. Chinese hotel industry has grown significantly, with international chains such as Marriott, Hilton, and Accor expanding alongside domestic brands like Jin Jiang and Huazhu. According to Statista in 2023, China had over 350,000 hotels and guesthouses, serving a wide range of travelers from budget tourists to luxury clients. The rise of high-speed rail networks has further boosted demand for accommodation in smaller cities.

Food and Beverage Services. The restaurant sector reflects China's diverse culinary traditions while catering to global tastes. From Michelin-starred restaurants in Shanghai and Beijing to small family-run eateries, the food and beverage industry plays

a vital role in hospitality. In 2023, revenue from China's catering industry surpassed 5 trillion yuan, making it one of the largest in the world.

**Digital transformation.** Online booking platforms like Trip.com, Fliggy, and Meituan have revolutionized hospitality services. Mobile payment systems (Alipay, weChat Pay) simplify transactions, while digital platforms provide real-time hotel reservations, restaurant bookings, and virtual travel experiences.

**Economic Impact.** Tourism and hospitality are critical drivers of China's economy. In 2019, the industry contributed around 11.05% of national GDP and supported over 80 million jobs (World Travel & Tourism Council, WTTC). Domestic tourism, in particular, has been central to China's strategy for balanced regional development, generating income for rural areas and promoting poverty reduction.

#### Challenges and Sustainable Development

1. **Over-tourism:** Popular destinations such as the Forbidden City often face overcrowding, threatening heritage conservation.
2. **Environmental Concerns:** Rapid tourism development has increased energy consumption, waste, and carbon emissions.
3. **Sustainability Policies:** The Chinese government promotes eco-friendly hotels, green transportation, and rural ecotourism projects. Programs like "Beautiful China" aim to balance growth with environmental preservation.

**Post-Pandemic Recovery and Future Trends.** China's tourism and hospitality industries were severely impacted by the Covid-2019 pandemic. However, strong recovery efforts have been observed since 2022, with domestic tourism leading the rebound. Future trends include:

- Growth of smart tourism with AI and big data applications.
- Expansion of rural and cultural tourism to support less-developed areas.
- Increasing focus on luxury hospitality and international service standards.

-Stronger emphasis on sustainable practices to align with global climate goals.

**Conclusion.** Hospitality and tourism in China have transformed into major pillars of the national economy. Rich cultural heritage, diverse natural landscapes, and a rapidly modernizing hospitality industry position China as both a global tourism leader and a dynamic domestic market. While challenges remain, particularly in sustainability and heritage protection, government strategies and technological innovation are shaping a resilient and future-oriented industry. The continued integration of hospitality and tourism will ensure that China remains a key player in the global tourism economy.

### References

1. UNWTO. (2020). International Tourism Highlights. Madrid: World Tourism Organization.
2. World Travel & Tourism Council (WTTC). (2020). Economic Impact Report: China.
3. Statista. (2023). Hotel Industry in China – Statistics & Facts.
4. China National Tourism Administration (CNTA). Annual Tourism Development Report.
5. Li, Y., & Ryan, C. (2018). Tourism, Heritage and Culture in China. Routledge.
6. Zhang, H., & He, J. (2021). Hospitality Development in China: Opportunities and Challenges. *Journal of Tourism Studies*.
7. Hunan Provincial Government. Policies on Tourism and Accommodation Development in Wulingyuan District; Changsha: 2017.
8. Zhao, Y. (2018). Sustainable tourism development and economic efficiency in China. PhD Dissertation, Sun Yat-sen University.
9. 李明, 张伟 (2017). 中国旅游服务业发展模式. 北京: 中国旅游出版
10. "China will be the world's most visited country by 2030". *the Guardian*. 2018-11-06. Retrieved 2021-10-05.
11. I.T.D., Research and Markets. "Hospitality Industry in China - Growth, Trends, and Forecast (2020 - 2025)". [www.researchandmarkets.com](http://www.researchandmarkets.com). Retrieved 2021-10-05.

## **Morphological Formation Features of Terms in the Economy of Household Services**

**Xayrullayeva Nodira Nematilloevna**

Doctor of Philosophy (PhD) in Science

**Xikmatova Nodirabegim Oybekovna**

First-year Master's student specializing in Linguistics (English language)

**Abstract.** This article analyzes the morphological formation features of terms used in the field of household services economics. The rapid development of this sector leads to the emergence of new concepts and terminological units. The study focuses on identifying the main morphological methods of term formation, including affixation, compounding, abbreviation, and borrowing. The structural and semantic characteristics of the formed terms are examined from a linguistic perspective. The research results demonstrate that internal language resources play a significant role in the development and systematization of sectoral terminology.

**Keywords.** household services economics, terminology, morphological formation, affixation, compound words, abbreviation, linguistic analysis

**Аннотация.** В статье анализируются морфологические особенности образования терминов в сфере экономики бытовых услуг. Быстрое развитие данной отрасли способствует появлению новых понятий и терминологических единиц. В исследовании рассматриваются основные морфологические способы образования терминов, включая аффиксацию, словосложение, аббревиацию и заимствование. Структурные и семантические характеристики образованных терминов анализируются с лингвистической точки зрения. Результаты исследования показывают, что внутренние ресурсы языка играют важную роль в формировании и систематизации отраслевой терминологии.

**Ключевые слова.** экономика бытовых услуг, терминология, морфологическое образование, аффиксация, сложные слова, аббревиация, лингвистический анализ

Terminology in the economy of household services which helps professionals communicate effectively, share knowledge, and understand complex processes. One main aspect of these terms is how they are formed. By studying their morphological structure—that is, how words are built using prefixes, suffixes, compound words, and abbreviations—we can better understand the logic behind these terms. This analysis not only helps to organize terminology but also makes it easier for people to use it correctly. Exploring the morphological formation of terms in the economy of household services is important for both linguists and practitioners, as it ensures clarity, consistency, and effective communication in this field.

Morphological analysis — the study of word formation and structure — is central to understanding how such terms are generated. Through mechanisms such as affixation, compounding, conversion, and abbreviation, languages develop terminology that is both systematic and communicatively efficient. This study investigates these morphological processes in the economy of household services, highlighting their theoretical significance and practical applications.<sup>1</sup>

Terminology research emphasizes the role of morphology in term formation. Morphemes, the smallest meaning-bearing units of language, combine to produce words that represent concepts in specialized fields.<sup>2</sup> In economics, morphological processes

---

<sup>1</sup> Crystal, D. (2008). *A dictionary of linguistics and phonetics* (6th ed.). Blackwell Publishing.

<sup>2</sup> Makarova, G. A., & Levontina, E. A. (2012). Morphological methods of term formation in the economic sphere. *Journal of Language and Terminology Studies*, 28(1), 45–59.

help create terms that denote abstract phenomena, professional roles, and organizational processes. Key mechanisms include:

1. *Derivation (Affixation)* – adding prefixes or suffixes to a base word to produce a new term.
2. *Compounding* – combining two or more independent words to create a single, conceptually unified term.
3. *Conversion (Word-Class Change)* – changing the grammatical category of a word without adding affixes.
4. *Abbreviation* – forming acronyms or shortened forms of complex expressions.

These processes facilitate clarity, brevity, and standardization in professional discourse, ensuring effective communication within the field of household services.

Derivation involves adding prefixes, suffixes, or infixes to a base word to create new terms. This is particularly productive in economic terminology, where abstract concepts and roles must be expressed precisely. These examples can be appropriate for this:

- *Xizmat* (service) → *Xizmatkor* (service provider)
- *Daromad* (income) → *Daromadli* (profitable)
- *Investitsiya* (investment) → *Investitsiyaviy* (investment-related)

Through affixation, the language can generate terms that denote specific functions, attributes, or positions within the economic sphere.<sup>3</sup>

Compounding combines two or more independent words to form a single term representing a complex concept. This method allows for precise denotation of interrelated economic phenomenon. Examples can be included such as:

- *Xizmat bozori* (service market)

---

<sup>3</sup> Запольская, Н. А. (2014). Морфологические аспекты терминообразования в экономическом дискурсе. *Вестник лингвистических исследований*, 4(22), 112–119.

- *Ish haqi* (salary)
- *Narx siyosati* (pricing policy)

Compounding is particularly useful in creating terms that are transparent and immediately understandable to speakers familiar with the base words.

Conversion, also known as zero-derivation, occurs when a word changes its part of speech without adding an affix. In economic terminology, verbs often convert into nouns to describe processes, systems, or concepts. Examples:

- *Boshqar-* (to manage) → *Boshqaruv* (management)
- *Rivojlan-* (to develop) → *Rivojlanish* (development)

Abbreviation is widely used in modern economic discourse to condense complex terms and improve communication efficiency. Acronyms and initialisms often become standardized terms in professional practice. Examples for abbreviations:

- *YaIM* – *Yalpi Ichki Mahsulot* (GDP – Gross Domestic Product)
- *QQS* – *Qo‘shilgan Qiymat Solig‘i* (VAT – Value Added Tax)

Abbreviations are particularly important in fields like economics, where long technical expressions are common, and quick comprehension is necessary.<sup>4</sup>

The study of morphological formation in household service economic terminology shows that affixation, compounding, conversion, and abbreviation are key mechanisms. Understanding these processes allows linguists and practitioners to systematize terms, maintain consistency, and facilitate clear communication within the field. Moreover, it demonstrates how language adapts to meet the practical needs of economic discourse.

### Used literature

---

<sup>4</sup> Selivanova, O. M. (2016). *Terminology and Terminology Management*. Springer.

1. Crystal, D. (2008). *A Dictionary of Linguistics and Phonetics* (6th ed.). Blackwell Publishing.
2. Запольская, Н. А. (2014). Морфологические аспекты терминообразования в экономическом дискурсе. *Вестник лингвистических исследований*, 4(22), 112–119.
3. Makarova, G. A., & Levontina, E. A. (2012). Morphological methods of term formation in the economic sphere. *Journal of Language and Terminology Studies*, 28(1), 45–59.
4. Murphy, M. L. (2010). *Lexical Meaning*. Cambridge University Press.
5. Selivanova, O. M. (2016). *Terminology and Terminology Management*. Springer.

## “THE SCORPION FROM THE ALTAR” NOVEL AND THE NATIONAL SPIRIT OF UZBEK LITERATURE

*Islom Karimov Tashkent State Technical University,  
Faculty of Mechanical Engineering,  
4th-year student of “Metals Technology” program  
Rayimqulov Diyorbek Akhror o‘g‘li*

**Annotation:** “Mehrobdan Chayon” was written during a period of sharp transformation in Turkestan at the beginning of a new era. Through the novel, Qodiriy reveals the roots of such social vices as moral decline, careerism, ignorance, backwardness, and injustice. The work places the “scorpion” — symbolizing betrayal, hypocrisy, and oppression — alongside the symbols of “love” and “justice,” exposing the hidden cruelty concealed beneath seemingly noble values.

**Keywords:** Abdulla Qodiriy, nationality, national identity, traditions and customs, realism, historical novel, artistic depiction, Uzbek literature, national consciousness, social life, traditions, culture, national heroes, the spirit of Uzbek identity, Anvar, Ra’no, творчество (creativity), character, the magic of words, structural component, analysis.

Atoqli o‘zbek yozuvchisi Abdulla Qodiriy “Mehrobdan chayon” romanini 1928-yilda yaratadi. Bu roman o‘zbek adabiyoti tarixida adibning “O‘tkan kunlar” dan keying ikkinchi asari bo‘ladi. Asar huddi “O‘tkan kunlar” kabi keng kitobxonlar tomonidan katta qiziqish bilan kutib olindi. Roman qahramonlari Anvar va Ra’nolar ham Otabek va Kumush kabi xalqimizning sevimli qahramonlariga aylanib ketdi..

Agar Farhodning Shirin, bo‘lsa Majnunlarning Laylosi,  
Nasib o‘lmish menga gulashan aro gullarning – Ra’nosi

(Mirzo)

Agar or etsa Layli haqlidir Qaysning jununidin,

Ne baxt, Ra'no, xaridoringtalab ahlining -Mirzosi

(Ra'no)

**Asarni " Mehrobdan chayon" deb adash , ziyoli ulamolarni qahramon qilib tanlashdan murod muqaddas dargoh - sajdagohdan chiqqan , o'sha dargohga nomunosib munofiq, qallob, tuban kimsalarga, hasadgo'y, e'tiqodsiz kishilarga ishoradir.**

Qodiriy asarlarida sevgi ko'pincha insonlarning ichki dunyosini ochib beruchi kuch sifatida tasvirlanadi. Masalan "mehrobdan chayon" romanida do'stlik va sadoqat qahramonlar hayotidagi qiyinchliklarni yengishda muhim rol o'ynaydi do'stlar o'rtasidagi munosabatlar, bir-biriga bo'lgan ishonchi va yordam berish istagi asarlarni yanada qiziqarli va hayajonli qiladi. Anvar характери haqida fikr yuritganda ham uning mantig'iga e'tibor qaratadi. Zarur o'rinlarda Otabek bilan qiyoslanadi.

Asarda Anvar obrazini batafsil tahlilini beradi. Uning kamtarin yigit ekani, Solih Mahdum eshigida asrandi sifatida ta'lim olishi, iste'dodli va qobilyatli bo'lsada, uning jamoatchilikda ko'z-ko'z qilavermasligi, hatto uni mirzaboshi qilib tayinlamoqchi bo'lishganda ham o'zini bu mansabga munosib, deb biladi, chunki u yosh bo'lishiga qaramay O'rdada bir necha yil oddiy mirzo bo'lib ishlab vaziyatni, muhit oqimini, odamlararo ziddiyatni to'la anglab yetgan va mirzaboshi etib tayinlansa hasadgo'ylik illatlari ishga tushishni aniq his qiladi.

Ra'no obrazi orqali Qodiriy ayolning jamiyatdagi o'rniga e'tibor qaratadi. Ra'no go'zallik va sadoqat timsoli bo'lish bilan birga, davr ayollarining fojeasini ham mujassamlashtiradi. Uning murakkab taqdiri jamiyatdagi adolatsizlikning oqibatlarini ko'rsatadi. Boylikka mahliyo, lekin irodasi sust inson.

Qodiriy bu obraz orqali boylar tabaqasining ichki bo'shlig'ini, ma'naviy ojizligiga tanqidiy munosabat bildiradi. Asarning ichki jarayonida ko'rinib turibdiki boshlanish tugunlar haqida gap ketganda, uning bir uchi Solih Maxdum bilan bog'lansa,

boshqa bir tomoni Abdurahmon domlaga borib taqalishi asoslanadi. Solih Maxdunga aloqador jihatini munaqqid Anvar mirzaboshi bo'lgandan keyin uni qizi Ra'noga uylantirish rejasi bilan asoslanadi. Kitobda Abdurahmon domla obrazi ham tahlilga tortilib, uning Buxoro madarasasida tayinli tahsil olmay boshqa nojoiz ishlar bilan shug'ullangani, o'qishni zo'rg'a tugatib oddiy bir imomlikka ilingani haqidagi tasvirlarga to'xtalar ekan, uning tabiatiga xos bo'lgan hasadgo'ylik hususiga to'xtaladi.

Gap shundaki, romanda Anvarning boshiga mushkul ish tushgan vaqtda, ya'ni Sultonali qamalib, uning hayoti xavf ostida turgan bir paytda bolaligida onasi tomonidan kimlargadir berib yuborilgan akasi Qobil o'rtoqlari bilan Samarqand tomonlardan ukasini so'roqlab kelib qoladi munaqqid oshnolarning "pul oshnasi emas odam oshnasi" ekani haqida kattagina parchani keltiradi va bu yozuvchi mahoarati sifatida baholaydi. Xullas Qobil va uning o'rtoqlarining qaltis paytida Anvarga yordam berishi, Safar bo'zchi va Anvar taraf xalq hamkorligida o'limdan qutqarib Toshkentga qochirib yuborishlari bir tasodifday tuyulsada, lekin yozuvchining badiiy asoslashi tufayli badiiy haqiqatga aylangani ta'kidlanadi. Bundan tashqari asarni yaratilgan davri ya'ni o'tgan asrning 20-yillarida adabiyot hali xalq og'zaki ijodi ta'siridan butkul uzoqlashib ketmagani, shu bois yozuvchi tasodiflardan unumli foydalangan, badiiylikni kuchaytirish uchun o'ziga xos badiiy usulni qo'llagan.

Asar yakunidagi kabi Anvar qiyofasidagi Qodiriyni xalq qutqarishiga umid bog'ladi. Zero Cho'lpon aytganidek "Xalq dengizdir, xalq to'lqindir, xalq kuchdir". Ming afsus...Abdulla Qodiriy hayotida uni qutqarguvchi xalq bo'lmadi. Lekin yozuvchining davrdosh-u davradosh, lek, darddosh bo'lolmagan hamkasblari mehrobdan chiqqan chayonlik vazifasini to'liq ado etdilar. Bundayin ruhdagi asarlari orqali Qodiriy o'z xalqiga, yurtdoshlariga, katta lavozimli amaldorlarga ko'zgudagi asl turqini ko'rsatib, rohat botqog'idan chiqishga chorladi. Ammo qon rangi xush ko'rguchi qizil imperiyaga Otabek-u Anvar emas, Obid ketmonlar kerak edi. Hammasi

tugadi.1938-yil 4-oktyabr millatimiz tarixidagi qonli sana. Abdulla Qodiriyning soʻngi soʻzlari esa hukmni ijro qiluvchi zobitga boʻldi. Soʻnggi istagim, iltimos ikki rakat namozimni oʻqib olay dedi.

Garchi “Oʻtgan kunlar”, “Mehrobdan chayon” sevgi qissasiga oʻxshasada, uning zaminida Vatan taqdiri, Vatan qaygʻusi yotadi.

Adib yuragida alamlar qat-qat,

Lekin bittasi bor, oʻchmasdir dogʻi:

Jonni tik ozodlik yoʻlida faqat,

Bu ustozning soʻnggi sabogʻi.

Xulosa qilib aytganda “Mehrobdan chayon” Abdulla Qodiriyning badiiy mahorati kamolga yetgan yirik asarlaridan biridir. Romanda ijtimoiy hayotning ogʻriqli nuqtalari, insoniylik va razillik kurashi, shaxsiy manfaat va adolat oʻrtasidagi ziddiyatlar chuqur tahlil etilgan. Qodiriy bu asar orqali oʻzbek adabiyotini yangi pogʻonaga olib chiqdi, realistik roman maktabining shakllanishiga ulkan hissa qoʻshdi. Asar bugun ham ahamiyatini yoʻqotmagan, insonni oʻylashga, oʻzligini anglashga chorlaydigan badiiy yodgorlik sifatida qadrlanadi.

#### Foydalanilgan adabiyotlar:

- 1.A.Qahhor. Asarlar. T.VI. Toshkent: Adabiyot va sanʼat nashriyoti, 1970. 411-bet. 2. Oʻ.Nosirov. Ijodkorshaxs badiiy uslub,avtor obrazi. Toshkent: Fan, 1981. 109-110-betlar. B.Karim. Dunyo olimlari nigohi. Avulla Qodiriy va germanevtik tafakkur maqola 2016
3. Abdulla Qodiriy. “Mehrobdan chayon” romani. Toshkent. 2019
4. I.Sulton. Adabiyot nazariyasi.Avtor nutqi va personaj nutqi. Toshkent:
5. Bashir. Oʻzbek adabiyoti.- Qozon, 1929. B.15
6. Ismatulla X.Abdulla Qodiriy abadiyati. Oʻzbekiston adabiyoti va sanʼati. 1994-yil 14 oktabr

## GAMIFICATION ELEMENTS AND MECHANICS IN FOREIGN LANGUAGE TEACHING

Gamification element and mechanics

**Xonqulova Mushtariy Abdurayim qizi**

Master`s student, University of Economics and Pedagogy

**Abstract:** This article examines the role of gamification elements and mechanisms in foreign language teaching. The aim of the study is to determine the impact of game elements on student`s motivation and language skills. The study was conducted based on theoretical analysis and observation in EFL groups. The results showed a positive impact on vocabulary, grammar, and speaking skills.

**Key words:** gamification, foreign language teaching, motivation, engagement, EFL, game mechanics, language acquisition

**Аннотация:** В статье исследуется роль элементов и механик геймификации в преподавании иностранного языка. Цель исследования — определить влияние игровых элементов на мотивацию, вовлеченность и языковые навыки студентов. Работа основана на теоретическом анализе и наблюдении в группах EFL. Результаты показывают положительное влияние на развитие лексики, грамматики, навыков говорения и аудирования.

**Ключевые слова:** геймификация, иностранный язык, мотивация, вовлеченность, игровые механики, EFL

**Annotatsiya:** Maqolada chet tilini o`qitishda gamifikatsiya elementlari va mexanizmlarining o`rni o`rganiladi. Tadqiqotning maqsadi o`yin elementlarining talabalar motivatsiyasi va til ko`nikmalariga ta`sirini aniqlashdir. Tadqiqot nazariy tahlil va EFL guruhlarida kuzatuv asosida olib borildi. Natijalar lug`at, grammatika va og`zaki nutq ko`nikmalariga ijobiy ta`sir ko`rsatdi.

**Kalit so‘zlar :** gamifikatsiya, chet tilini o‘qitish, motivatsiya, o‘yin mexanizmlari, EFL, til o‘zlashtirish

## **Introduction**

Education in the modern world is rapidly changing due to digital technologies and globalization. Students today grow up with smartphones, social media, and online platforms. As a result, their learning preferences are different from previous generations. Traditional teacher-centered instruction may not always be effective in maintaining students' attention.

Foreign language learning is a complex process that requires constant practice, repetition, communication, and confidence. Many learners feel anxiety when speaking in a foreign language. Fear of making mistakes reduces participation. Therefore, teachers must create a supportive and motivating environment.

Gamification has emerged as an innovative pedagogical strategy. It integrates game elements into educational contexts without turning the lesson into a full game. Researchers argue that gamification increases engagement because it activates emotional involvement. When students receive points or rewards, they feel recognized. When they move to a higher level, they see their progress clearly.

Moreover, gamification aligns with constructivist learning theory, where learners actively build knowledge through interaction. It also supports communicative language teaching by encouraging participation and collaboration. Thus, investigating gamification in foreign language teaching is important for modern pedagogy.

## **Methodology**

This research was conducted using a qualitative descriptive approach. The main purpose of the study was to explore how gamification elements function in real foreign language classrooms and how they influence students' behavior and performance.<sup>1</sup>Gamification

---

<sup>1</sup> Deterding, S. (2011). Gamification in education.

means using game design elements in non-game contexts. He explains that gamification is not about playing full games in class, but about adding small elements such as points, levels, and achievements to increase engagement. This definition helps teachers understand that gamification is a structured educational strategy.

The research was carried out in two intermediate-level EFL groups. Each group included approximately twenty students. The participants were university students who had basic knowledge of English but experienced difficulties in speaking fluently and remembering vocabulary.<sup>2</sup>

The study lasted for four weeks. During the first phase, traditional teaching methods were used. In the second phase, gamification elements were introduced into lessons. This structure allowed comparison between two teaching approaches.

Several tools were used to collect data:

- Direct classroom observation
- Monitoring student participation frequency
- Short vocabulary and grammar quizzes
- Informal student reflection forms
- Teacher field notes

<sup>3</sup>Gamified activities included vocabulary competitions, grammar missions divided into levels, speaking role-play tasks structured as challenges, and listening exercises with time-based scoring. Some activities used digital tools, while others were paper-based.

The collected data was analyzed by comparing participation levels, test results, and observed behavioral changes. The analysis focused on identifying patterns in motivation, confidence, and language accuracy.

---

<sup>2</sup> Sheldon, L. (2011). The Multiplayer Classroom.

<sup>3</sup> Kapp, K. (2012).. The Gamification of Learning and Instruction.

## Results

<sup>4</sup>The findings of the research show that gamification positively influenced students' engagement and learning outcomes.

First, student participation increased noticeably. During traditional lessons, only the most confident students answered questions. After introducing game elements, a larger number of students became actively involved. The classroom atmosphere became more energetic and interactive.

Second, vocabulary retention improved. Students remembered new words more effectively when they practiced through competitive quizzes and repeated challenges. The element of scoring encouraged them to pay closer attention.

Third, grammar accuracy showed improvement. When grammar exercises were presented as "missions" instead of formal tests, students completed tasks more carefully. Immediate feedback helped them understand their mistakes without feeling discouraged. Fourth, speaking confidence increased. Students were more willing to participate in role-play activities when these tasks were framed as creative challenges. Anxiety decreased because the focus shifted from evaluation to participation.

Listening comprehension also improved. Time-limited listening challenges encouraged students to concentrate more carefully.

However, the research also identified minor difficulties. Some learners focused mainly on winning points rather than understanding content deeply. In rare cases, competition caused pressure. This suggests that gamification must be implemented thoughtfully.

## Discussion

The results confirm that gamification can significantly improve motivation in foreign language learning. The success of gamification can be explained through psychological and educational theories.

---

<sup>4</sup> Buckley, P. (2017). Student Engagement and Gamification.

Gamification works because it combines emotional involvement with cognitive effort. When students experience enjoyment, their attention increases. Emotional engagement supports memory and understanding.

Game elements such as points and badges provide external rewards. However, the most important effect comes from internal satisfaction. When students see their progress and improvement, they develop self-confidence. This internal motivation is essential for long-term language learning.

Gamification also creates a supportive classroom environment. Students feel less afraid of making mistakes because errors are seen as part of the learning process. This reduces language anxiety, which is a common problem in foreign language education.

Another important aspect is collaboration.

When students work in teams, they develop communication skills and social responsibility. Cooperative tasks help balance competition.

Despite these benefits, gamification is not a universal solution. Teachers must design activities that align with clear learning objectives. Game elements should support educational goals rather than distract from them.

Long-term success depends on balance. External rewards should gradually encourage internal motivation. The main aim remains language development, not entertainment.

### **Conclusion**

In conclusion, gamification elements and mechanics have a strong positive impact on foreign language teaching. They improve motivation, participation, vocabulary retention, grammar accuracy, and speaking confidence. Gamification creates an interactive and supportive learning environment that reduces anxiety. However, successful implementation requires careful planning. Teachers must balance competition with cooperation and ensure that learning objectives remain central. Gamification should be used as a supportive pedagogical tool, not as pure entertainment.

Overall, gamification represents a promising approach for modern foreign language education. Future research may focus on long-term effects and quantitative measurement of academic achievement.

### **References**

1. Deterding, S. (2011). Gamification in education.
2. Kapp, K. (2012). The Gamification of Learning and Instruction.
3. Werbach, K., & Hunter, D. (2012). For the Win.
4. Zichermann, G., & Cunningham, C. (2011). Gamification by Design.
5. Hamari, J. (2014). Does gamification work?
6. Deci, E., & Ryan, R. (2000). Self-Determination Theory.
7. Sheldon, L. (2011). The Multiplayer Classroom.
8. Prensky, M. (2001). Digital Game-Based Learning.
9. Gee, J. (2003). What Video Games Have to Teach Us About Learning.
10. Sheldon, L. (2011). The Multiplayer Classroom.
11. Buckley, P. (2017). Student Engagement and Gamification.
12. Lee, J. (2013). Gamification in Education Research.

**TABLE OF CONTENTS | СОДЕРЖАНИЕ**

1.	<b>ANALYSIS OF FACTORS INFLUENCED IN THE DEVELOPMENT OF THE POULTRY INDUSTRY</b> <i>Holida Hayitnazarova</i>	3-8
2.	<b>ANALYSIS OF THE USE OF THE ARIMA MODEL IN FORECASTING ECONOMIC INDICATORS</b> <i>Sohiba Turopova</i>	9-14
3.	<b>INFORMATION TECHNOLOGIES OF TEACHING IN LINGUISTICS</b> <i>Rano Abdurakhmanova</i>	15-19
4.	<b>ISSUES OF TRANSLATING SCIENTIFIC TERMS FROM ENGLISH INTO UZBEK</b> <i>Saodatxon Tursunova</i>	20-26
5.	<b>THE ROLE OF A SCHOOL PSYCHOLOGIST IN WORKING WITH GIFTED STUDENTS: THEORETICAL FOUNDATIONS AND PRACTICAL MECHANISMS</b> <i>Iroda Saitqulova</i>	27-34
6.	<b>Legal status and powers of the Chamber of Advocates of the Republic of Uzbekistan</b> <i>Sholpanay Abdijemilova</i>	35-39
7.	<b>PROFESSIONAL ETHICS OF A LAWYER IN THE SYSTEM OF LEGAL REGULATION</b> <i>Zulfiya Ibragimova</i>	40-45
8.	<b>Distinctive Characteristics of Nipah Virus</b> <i>Vasila Salaydinova , Azizbek Xasanov , Bekjon Mirzayev</i>	46-48
9.	<b>Issues of Transforming the Creative Heritage of Nizami and Navoi into an International Literary Tourism Brand</b> <i>Ulug‘bek Mamadaliyev , Rizobek Abdumannonov</i>	49-61
10.	<b>The role of morality and etiquette in Arab folk proverbs</b> <i>Mastura Nurmatova</i>	62-68
11.	<b>Theme: Criminal-Legal Essence of Domestic Violence and the Grounds for its Criminalization</b>	69-81

	Fayzullo Baxramov	
12.	<b>PROSPECTS FOR THE FORMATION AND DEVELOPMENT OF ARTIFICIAL INTELLIGENCE POLICY IN UZBEKISTAN</b> Shohista Amirova	82-84
13.	<b>THE DIPLOMATIC AND CULTURAL SIGNIFICANCE OF UNESCO'S 43RD SESSION FOR UZBEKISTAN</b> Dilrabo Mavlanova	85-90
14.	<b>THE MORAL AND SPIRITUAL CHOICE BETWEEN FAITH AND CONSCIENCE IN THE VIEWS OF OZOD SHARAFIDDINOV</b> Dilrabo Mavlanova	91-95
15.	<b>Smart Tourism Attributes and Tourist Satisfaction: Evidence from Uzbekistan</b> Nasiba Mukhtorova	96-107
16.	<b>STRENGTH AND CRACK RESISTANCE OF BASALT FIBER-STRENGTHENED REINFORCED CONCRETE BEAMS WITH COMPOSITE REINFORCEMENT: A COMPARATIVE ANALYSIS BASED ON EUROCODE 2</b> Shahzoda Muxtorova , Ayubxon Nazirov	108-118
17.	<b>The Role of Ecotourism and Its Prospective Directions in Uzbekistan's Tourism Sector</b> Nargiza Choriyeva	119-127
18.	<b>Development of Digital Banking in Uzbekistan Over the Past Five Years</b> Akbarov Sherali	128-131
19.	<b>ARUZ AND ARTISTIC EXPRESSION: ON THE EXAMPLE OF SAYFI SARAYI'S POETRY</b> Barno Qodirova	132-139
20.	<b>COMPARATIVE STUDY OF ADJECTIVE DEGREES IN ENGLISH AND UZBEKISTAN</b> Dilobar Azimova , Vasila Mamurova	140-144
21.	<b>Clinical and Diagnostic Significance of Metabolic Dysfunction and Liver Fibrosis Stages in Patients with Non-Alcoholic Fatty Liver Disease (NAFLD)</b> Muhammadali Isroilov , Alisher Soliyev	145-146

22.	<b>The Influence of Slang on the Contemporary English Lexicon: A Sociolinguistic and Digital-Era Perspective</b> <i>Iroda Sirojiddinova</i>	147-156
23.	<b>FEATURES OF EARLY DIAGNOSIS OF DIABETIC NEPHROPATHY</b> <i>Shoira Kodirova</i>	157-160
24.	<b>Optimizing Pregravid Preparation in the Prevention of Various Pregnancy Complications and Congenital Fetal Abnormalities</b> <i>Zilola Solieva , Feruza Nosirova</i>	161-163
25.	<b>AIR POLLUTION BY DUST AND CHEMICALS: PROBLEMS, CONSEQUENCES, AND SOLUTIONS</b> <i>Odina Kasimova , Mehrangiz Jo‘rayeva , Sabrina Fozilova</i>	164-167
26.	<b>EMOTIONAL INTELLIGENCE OF A STUDENT AS A FACTOR OF SUCCESS IN EDUCATION</b> <i>Bakhriddin Umarov</i>	168-171
27.	<b>Cytotoxic Activity of 1,2,4-Triazole Derivatives as Nucleoside Analogues with Antiviral Potential</b> <i>Nigora Tosheva , Sobirdjan Sasmakov , Shakhnoz Azimova</i>	172-173
28.	<b>PRODUCTION OF PHARMACEUTICAL PRODUCTS: PROCESSES AND METHODS FOR IMPROVING EFFICIENCY – GLOBAL EXPERIENCE</b> <i>ALISHER ABDUJABBAROV</i>	174-183
29.	<b>The Role of Education and Cognitive Growth in Shaping Characters</b> <i>Mohigul Kakharova</i>	184-186
30.	<b>CREATION OF MODERN TECHNOLOGIES FOR STRENGTHENING THE WORKING SURFACE OF THE DETAILS OF THE BELT CONVEYOR ROLLER MECHANISM</b> <i>Akbarjon Jumaev , Muattar Abdurakhmanova , Dadanazar Abdullaev</i>	187-192
31.	<b>TECHNOLOGY AND CONSTRUCTION FEATURES OF MEN’S TROUSER SEWING</b> <i>Azizaxon Mendiboyeva</i>	193-198
32.	<b>TECHNOLOGY AND CONSTRUCTION FEATURES OF MEN’S SHIRT SEWING</b> <i>Mahmuda Shakirova</i>	199-204

33.	<b>TECHNOLOGY AND DESIGN FEATURES OF SEWING MODERN WOMEN'S DRESSES</b> <i>Odinaxon Soliyeva</i>	205-210
34.	<b>TECHNOLOGY AND ARTISTIC-CONSTRUCTION FEATURES OF SEWING WOMEN'S NATIONAL DRESSES</b> <i>Olmaxon Nazirova</i>	211-216
35.	<b>HOSPITALITY AND TOURISM IN CHINA</b> <i>Shohida Nabijonova</i>	217-220
36.	<b>Morphological Formation Features of Terms in the Economy of Household Services</b> <i>Nodira Xayrullayeva , Nodirabegim Xikmatova</i>	221-225
37.	<b>“THE SCORPION FROM THE ALTAR” NOVEL AND THE NATIONAL SPIRIT OF UZBEK LITERATURE</b> <i>Diyorbek Rayimqulov</i>	226-229
38.	<b>GAMIFICATION ELEMENTS AND MECHANICS IN FOREIGN LANGUAGE TEACHING</b> <i>Mushtariy Xonqulova</i>	230-235